

## Working Condition and Specification

### 1.1 Working Condition:

Power supply: AC220V±10%

Frequency: 50HZ±0.5

Humidity: <85%

Environment Temperature: 0°C ~ +40°C

Magnetic Field: <400 A/m

Spark and fire is prohibited.

### 2.2 Specifications:

Fuel Tank Capacity: 2000 ml

Capacity of Measuring Cylinder: 125 ml

Speed Range: 0~7500 rpm

Injecting Times: 0~9900 Step: 100ms

PWM Pulse: 0~20.0 ms Step: 0.1 ms

System Pressure: 0~0.6Mpa(adjustable)

Time: 0~20 minute (adjustable)

Power of Ultrasonic Cleaning: 70W

Frequency of Ultrasonic Cleaning: 28 KHZ±0.5 KHZ

## II Structure

### 2.1 Structure

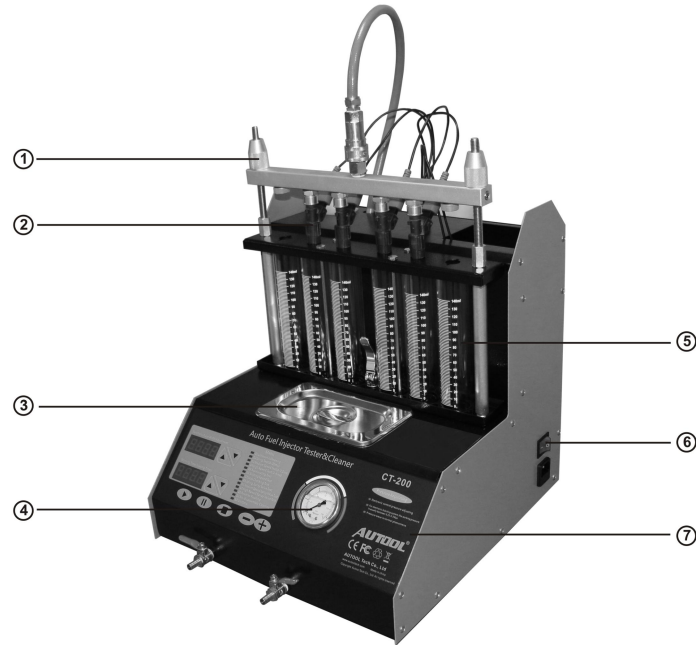

- ① Fasten bolt                      ② Fuel distributor                      ③ Ultrasonic trough
- ④ Pressure meter                      ⑤ Measuring                      ⑥ Power switch
- ⑦ Operation panel

### 2.2 Operation Panel

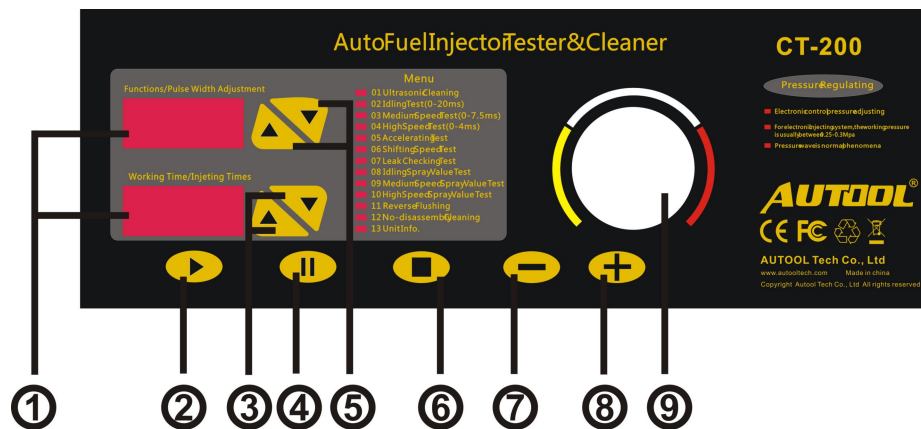

- 1. LED screen

2. Start: To run the function that selected;
3. Arrow key: To adjust pulse working time and injection times;
4. PAUSE
5. Arrow key: To select function item and adjust pulse width ;
6. STOP
7. Pressure down
8. Pressure up
9. Pressure Meter

### **III Operation**

#### **3.1 Ultrasonic Cleaning**

##### **3.1.1 Preparation**

- 1) Move the injector from the car. Check and make sure that the seal ring of the injector is in good condition. If not, please replace it to avoid the leakage. Clean out side of injector carefully by gasoline or cleaning fluid.

- 2) Connect the machine to power supply and turn it on.
- 3) Put the cleaning frame on the ultrasonic groove, and put the injector into the whole of the frame.

### **3.1.2 Steps**

#### **01 Ultrasonic Cleaning**

- 1) Pour proper quantity cleaning fluid into ultrasonic groove.
- 2) Connect the actuation cable to the injector needed to be cleaned.
- 3) Press Left or Right Arrow key to select “Ultrasonic Cleaning” from panel, then press “RUN” key.
- 4) Press Left or Right Arrow key to set up working time ( default time is 10 minutes) .
- 5) Press “RUN” key. (You can press PAUSE or STOP at any time during the operation process.)
- 6) After the cleaning is completed, it will stop automatically.
- 7) Take the injector out of the ultrasonic groove.

#### **NOTE:**

1. During the cleaning, get the injector close to ear, listen carefully, you may hear the intermittent sound of closing and opening of the injector’s valve, otherwise the injector’s valve is blocked.
2. Please do not turn on the ultrasonic trough when there is not clean fluid in the trough, otherwise the machine will be damaged.

### **3.2 Injector Test**

This function is to test the condition of atomization, drop, block, spray angle, and uniformity of the injector.

### 3.2.1 Preparation

- 1) Pour about 1900ML test fluid into the machine through measuring cylinder.
- 2) Install the injector

#### Installation of Up-inlet Injector

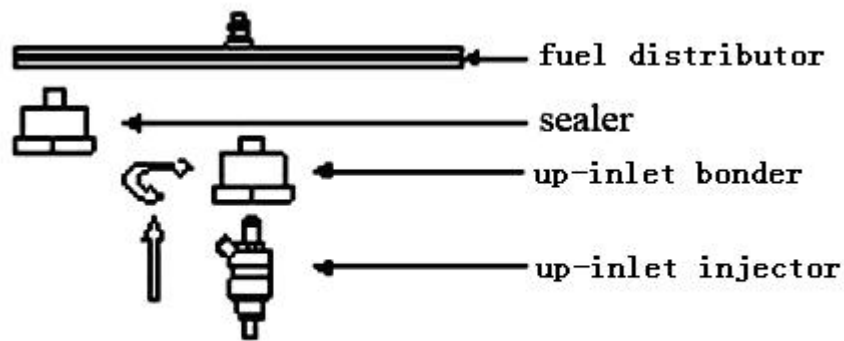
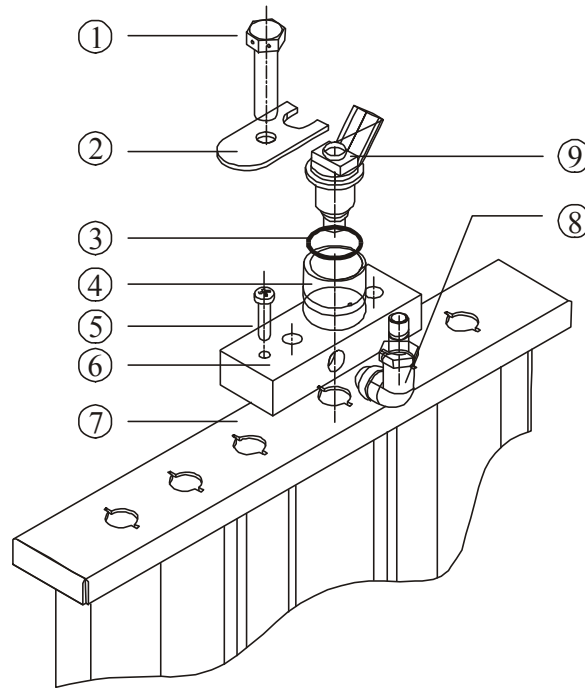

Illustration 2.1 installation of up-inlet injector

- a. Take the coupler and plugs from the toll drawer and install them to fuel distributor.
- b. Put some grease on the "O" ring of the injector, and install it into the coupler of the fuel distributor.
- c. Put the fuel distributor and injector on the machine and fasten it by fasten bolt.  
(For some special injector, it need to use lengthened bolt, washer to fasten it.)

#### Installation of Side-feed Injector



**Installation Diagram**

- a. Select the suitable coupler④ and “O” loop③, and then put the “O” loop on the coupler. (Put a little lubricant on the coupler and the “O” loop.)
- b. Put the injector⑨ into the coupler, and then put them together into the fuel distributor⑥.
- c. Install the hold plate②. Tighten the screw⑤ on the hold plate. Adjust the suitable height by screw④.
- d. Install the fuel distributor and injector to the fuel distributor rack⑦.
- e. Connect the adaptor of black hose with the male terminal⑧ on the fuel distributor. Connect the drive wire of injector, and prepare to test.

### **3.2.2 Steps**

#### **02 Idle Speed Test**

- 1) Connect black hose (outlet) to inlet port of the fuel distributor, and then connect the actuation cable to the machine.
- 2) Press Left or Right Arrow key to select Idle Speed Test, then press RUN key.

- 3) Press Left or Right Arrow key to set up working time. (Normally, it is 2 minutes.)
- 4) Press RUN key.
- 5) Turn Pressure Adjusting Knob until the pressure is 0.25-0.3MPa..
- 6) Press Left or Right Arrow key to select proper injection pulse (default value is 3MS).
- 7) When the working time is zero, the machine will stop.
- 8) Release the fluid into the pump after test is completed.

### **03 Medium Speed Test**

- 1) Press Left or Right Arrow key to select Medium Speed Test.
- 2) Press RUN key.
- 3) The next steps are the same as what listed in 02 Idle Speed Test.

### **04 High Speed Test**

- 1) Press Left or Right Arrow key to select High Speed Test.
- 2) Press RUN key.
- 3) The next steps are the same as what listed in 02 Idle Speed Test.

### **05 Accelerating Test**

- 1) Press Left or Right Arrow key to select Accelerating Test.
- 2) Press RUN key.
- 3) The next steps are the same as what listed in 02 Idle Speed Test.

### **NOTE:**

1. System pressure, working time and pulse width are set up automatically by system itself. (Default working time cycle is 10 seconds.)
2. System will automatically simulate 3 times accelerating cycle from 750 RPM to

7500 RPM to test the injection condition of the injector.

### **06 Shifting Speed Test**

- 1) Press Left or Right Arrow key to select Shifting Speed Test.
- 2) Press RUN key.
- 3) The next steps are the same as what listed in 02 Idle Speed Test.

#### **NOTE:**

1. System pressure, working time and pulse width are set up automatically by system itself. (Default working time cycle is 10 seconds.)
2. System will automatically simulate 3 times of engine condition of 750 RPM, 4000RPM, and 7500 RPM to test the injection condition of the injector.

### **07 Leakage Test**

- 1) Press Left or Right Arrow key to select Leakage Test.
- 2) Press RUN key.
- 3) The next steps are the same as what listed in 02 Idle Speed Test.

#### **NOTE:**

1. Default pulse width is 3ms.
2. System simulates 0.3Mpa system pressure to test leakage.

### **08 Idling Spray Value Test**

- 1) Press Left or Right Arrow key to select Idling Spray Value Test, then press RUN key.
- 2) Press Left or Right Arrow key to set up injecting time (account time)
- 3) The next steps are the same as what listed in 02 Idle Speed Test.

#### **NOTE:**



To simulate the injecting condition after working for a certain times in Idle speed

### **09 Medium Speed Spray Value Test**

- 1) Press Left or Right Arrow key to select Medium Spray Value Test, then press RUN key.
- 2) The next steps are the same as what listed in 08 Idling Spray Value Test.

### **10 High Speed Spray Value Test**

- 1) Press Left or Right Arrow key to select Medium Spray Value Test, then press RUN key.
- 2) The next steps are the same as what listed in 08 Idling Spray Value Test.

#### **NOTE:**

1. Check the deviation of the spray value: test the spray value in different rpm, check the spray value in different measuring cylinder, the deviation should not exceed 2% or refer the specification of the injector.
2. Leakage test: leakage should not occur within 1 minute under 0.3MPA system pressure.

### **3.3 Reverse Flushing**

The flush fluid go into the injector through its outlet and go out through its inlet, so that it can clean the filth inside, which can not be cleaned by normal way.

#### **3.3.1 Preparation**

- 1) Pour about 1900ML test fluid into the machine through measuring cylinder.
- 2) Install the injector.

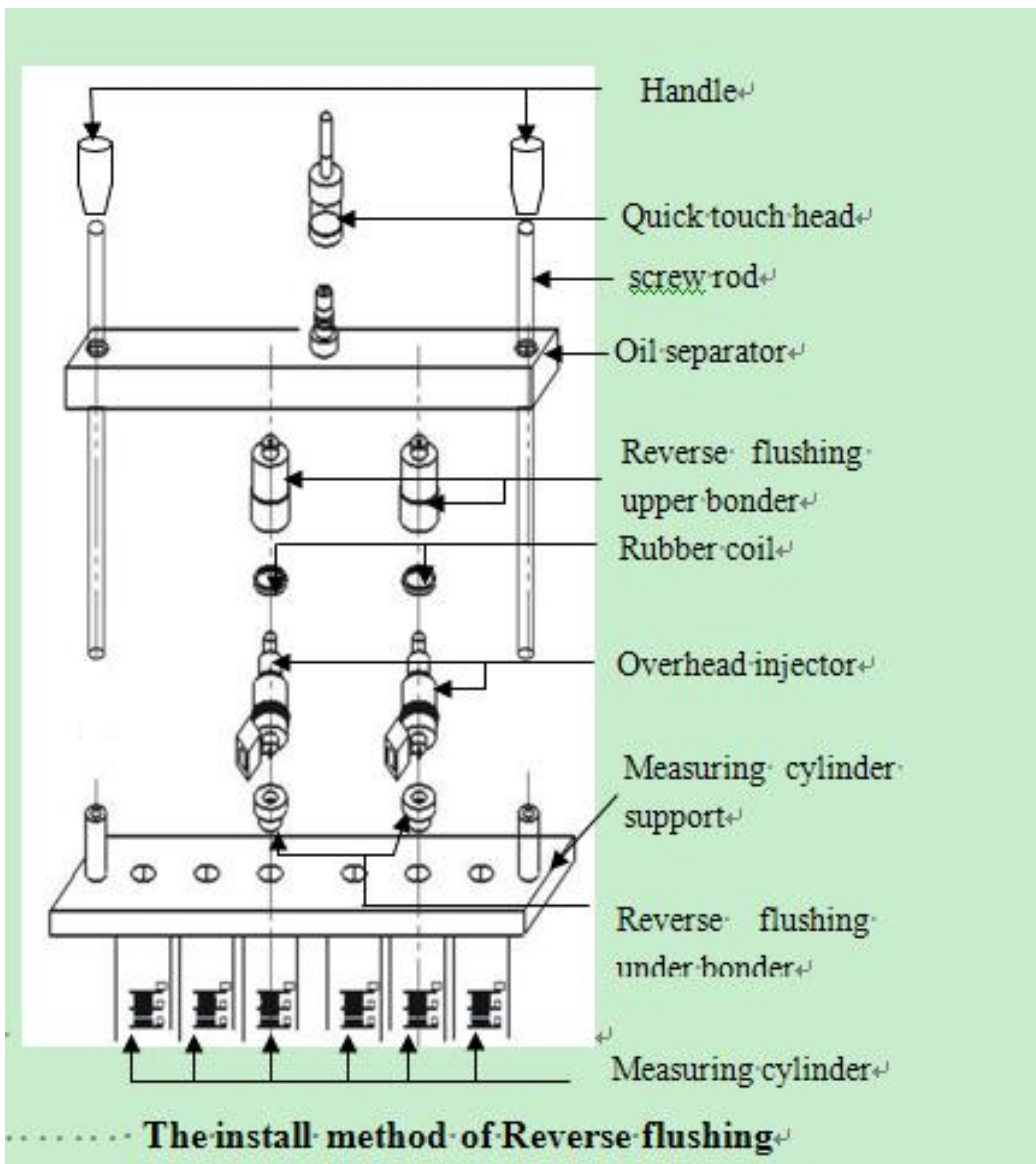

- a. Screw the reverse flushing bonder (5) on the fuel distributor.
- b. Put reverse flushing "O" ring on the injector, and install injector by reverse direction.
- c. Put the reverse flushing bonder (9) on the cylinder bracket.
- d. Fasten the injector on the machine (see Fig. above).

### 3.3.2 Steps

#### 11 Reverse Flushing

- 1) Connect black hose (outlet) to inlet port of the fuel distributor, and then

connect the actuation cable to the machine.

- 2) Press Left or Right arrow key to select Reverse Flushing.
- 3) Press RUN key (default test time is 1 minute).
- 4) Turn Pressure Adjusting Knob until the pressure is 0.25-0.3MPa.
- 5) When the working time is over, the machine will stop.
- 6) Release the fluid into the pump after test is completed.

**Note:**

1. Only up-inlet injector can fit Reverse Flushing.
2. Need not set up pulse width, system use default value.
3. Please make sure the test fluid is clean, so that the injector will not be blocked.

**3.4 Non-dismantle Cleaning(optional function)**

To clean the whole fuel system of the engine, including fuel supply system, burning room and the injector. .

**3.4.1 Preparation**

- 1) Move the screw on the bottom of test fluid bottle, and release all test fluid.
- 2) Open the cover of the engine chamber. Find out the fuel supply hose and return hose of the fuel system.

**3.4.2 Steps**

**12 Non-dismantle Cleaning**

- 1) Take the red long hose from the accessories box. Connect one end to return hose of the engine, and the other end to the return hose port of the machine.
- 2) Run the engine, and check the test fluid bottle. When the level is up to 600-800ML, stop the engine.

- 3) Take the long blue hose from the accessory box. Connect one end to the high pressure port of the machine, and the other end to the supply hose of the engine fuel system.
- 4) Move the pump relay of the engine or short connect the fuel circuit of the engine fuel pump. (In this case, please make sure the cover of fuel tank is open.)
- 5) Turn on the machine. Press Left or Right Arrow key to select Non-dismantle Cleaning, and set up the time as 20-30minutes.
- 6) Adjust system pressure, (normally the pressure should between 0.25-0.3Mpa).
- 7) Press RUN key, and turn on the engine after several seconds.
- 8) Pour Non-dismantle cleaning fluid into one of the measuring cylinder of the machine (0.5 bottle for 4 cylinder engine, 0.75 bottle for 6 cylinder engine, and one bottle for 8 cylinder engine).
- 9) Adjust engine speed, make it to run 1-10 minute under idle speed, 10-15 minutes under medium and high speed;, and run under idle speed again in the rest of the time.
- 10) When the setting time is zero, the machine will stop automatically. Remove the hose and let the engine back to its normal condition.
- 11) Turn on the engine and run it for 2-3 minutes under high speed, and check if there is any leakage occurs.

**Note:**

- 1) The Non-dismantle cleaning fluid is inflammable, so please take care to avoid any hurt.

2) Make sure that all the connections are in good condition before performance the cleaning.

## **IV Tidy and Maintenance**

### **4.1 Tidy**

**Step 1:** Shut down the power supply.

**Step 2:** Put the test and cleaning fluid back to the original bottle, and clean the machine with dry soft cloth.

**Step 3:** The testing fluid in tank should be put back to original bottles for preservation.

### **4.2 Maintenance**

#### **Exchange Cleaning Fluid**

After being used for long time, the fluid must be changed to avoid that the injector is blocked by the impurity.

#### **Exchanging Process**

**Step 1:** Remove the fluid-release screw cap to let all the liquid out.

**Step 2:** Pour some new fluid to wash the inside and then release it.

**Step 3:** Fix the screw cap on, and add two bottles of new cleaning fluid.

#### **Exchange Protector Tube**

**Step 1:** The protector case is on the unit's power receptacle.

**Step 2:** Open the case, and then you will see the tube.

**Step 3:** Change a new one if the tube was melted.

## **Notice**

1. The measuring cylinders are made of quartz glass, and fragile. **No striking!**
2. Before start the unit, please check the power supply, connector plugs and protector tube to ensure that they are in good condition.
3. Warranty will be cancelled if dismantle the unit without permission.
4. Damage will occur if run the ultrasonic cleaning function without special cleaning fluid.
5. Before exchanging the new testing fluid, the used one must be released entirely, then adding two bottles (1800ml) for using.
6. Taking use of the special testing or cleaning fluids which designed for unit, for other ones will flake the surface painting coat off..
7. Never using coal oil, petrol or thinner for as cleaning or testing fluid.
8. Never mix the testing and cleaning fluids for usage.
9. The trouble caused by using other fluids or liquid is beyond the repairing guarantee range.

## **V The Cleaning and Testing Fluids**

Safety and innocuity, the fluids are specially designed for the unit and composed of sediment controlling fluid, with high stability and oxidation resistance, resuming injector unimpeded, normal spray, eliminate the troubles of idling unsteadiness, accelerating hard, and improve combustion performance, saving the petrol cost.

To avoid burning the unit's core oil pump and fretting the oil piping system, the fluids are kept from any acid or base component from any acid or base component.

## VI Warranty

Thank you for choosing this product. Following service and warranty apply:

1. This product is warranted to be free from defects for a period of one year from date of purchase.
2. For the repairs out of warranty period, we only charge the cost of parts.
3. For updating the unit, we only charge the cost.
4. If your unit needs repair or replacement parts, contact your local distributor or our company. We will serve you ASAP.
5. To validate your warranty, please complete the warranty card attached to your unit, and return it. We will keep your record, and serve you.
6. Followings do not apply to our warranty:
  - 1) The broken of measuring cylinder, actuation cable, couples and adaptors, pressure meter.
  - 2) The consumption: test fluid, cleaning fluid, Non-dismantle cleaning fluid.
  - 3) The broken of the ultrasonic system caused by turning on the ultrasonic trough when there is not cleaning fluid in it.
  - 4) Pump broken caused by not changing test fluid for long time.
  - 5) Pump broken caused by using test fluid that is not approved by our company.
  - 6) Pump broken caused by wrong using of the test fluid or cleaning fluid.
  - 7) Broken caused by incorrect operation.

Web: [www.autooltech.com](http://www.autooltech.com)



Tel: 0086-755-27807580