

VEVOR[®]

TOUGH TOOLS, HALF PRICE

Technical Support and E-Warranty Certificate www.vevor.com/support

WIRE STRIPPING MACHINE INSTRUCTION MANUAL

We continue to be committed to providing you with tools at a competitive price. "Save Half",

"Half Price" or any other similar expressions used by us only represent an estimate of savings you might benefit from buying certain tools with us compared to the major top brands and do not necessarily mean to cover all categories of tools offered by us. You are kindly reminded to verify carefully when placing an order with us if you are actually saving half compared to the top major brands.

VEVOR®

TOUGH TOOLS, HALF PRICE

WIRE STRIPPING MACHINE

MODEL:038-MDA

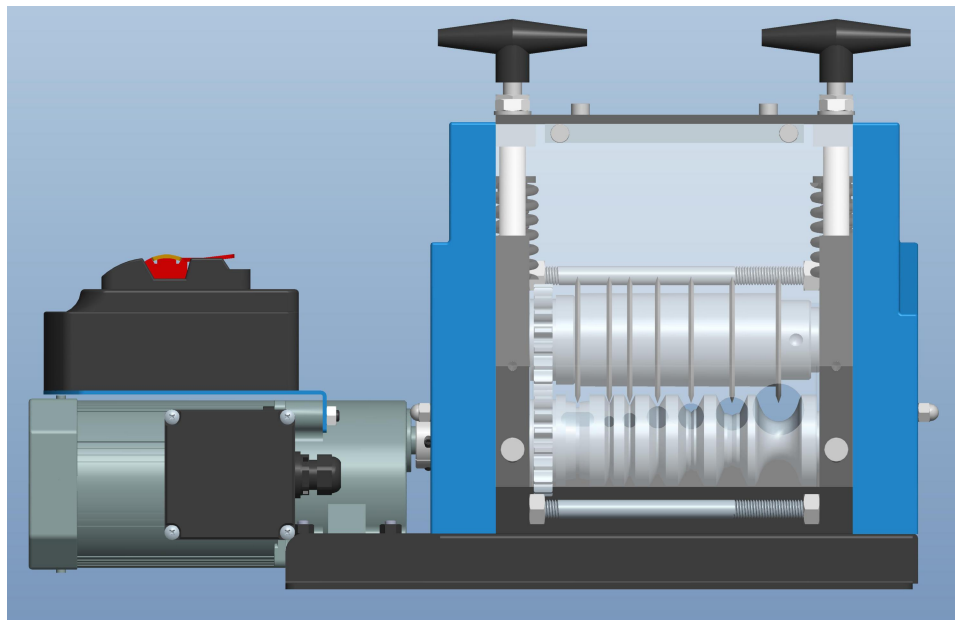

NEED HELP? CONTACT US!

Have product questions? Need technical support? Please feel free to contact us:

✉ CustomerService@vevor.com

This is the original instruction, please read all manual instructions carefully before operating. VEVOR reserves a clear interpretation of our user manual. The appearance of the product shall be subject to the product you received. Please forgive us that we won't inform you again if there are any technology or software updates on our product.

This is the original instruction, please read all manual instructions carefully before operating. VEVOR reserves a clear interpretation of our user manual. The appearance of the product shall be subject to the product you received. Please forgive us that we won't inform you again if there are any technology or software updates on our product.

WARNINGS

Read carefully and understand all ASSEMBLY AND OPERATION INSTRUCTION before operating, When using the wire stripping machine, basic safety precautions should always be followed including the following:

1. Read and follow all instructions before using the machine.
2. To prevent the risk of electrical shock, do not immerse in water or other liquids. Use a damp cloth to clean the motor housing.
3. Children shall not play with the appliance. Cleaning and user maintenance shall not be made by children without supervision.
4. When not in use, unplug from the outlet before installing or removing parts and before cleaning.
5. Avoid contacting moving parts.
6. Do not operate any machine with a damaged cord or plug or after the appliance malfunctions, or is dropped or damaged in any manner. Return appliance to the nearest authorized service facility for examination, repair or electrical or mechanical adjustment.
7. The use of attachments not sold by the manufacturer is not recommended and may cause fire, electric shock or injury.
8. Do not use outdoors.
9. Do not allow cord to hang over edge of table or counter.
10. Never run the machine unattended.
11. Type Y attachment: If the supply cord is damaged, it must be replaced by the manufacturer, its service agent or similarly qualified persons in order to avoid a hazard.
12. Never put your hand in when the machine is running (you must stop the machine before checking, debugging and troubleshooting the machine). To

avoid cutting your hand,do not touch the blade directly with your hand.

TECHNICAL PARAMETER

Model	Dimension (L*W*H mm)	Weight (kg)	Voltage	Power (W)	Stripping range (mm)
038-MDA	480×165×310	15.5	220V-240V~ 50Hz	60	∅1~∅25
			110V~ 60Hz		

Note: this machine is not applicable to silicone rubber cables or armored cables

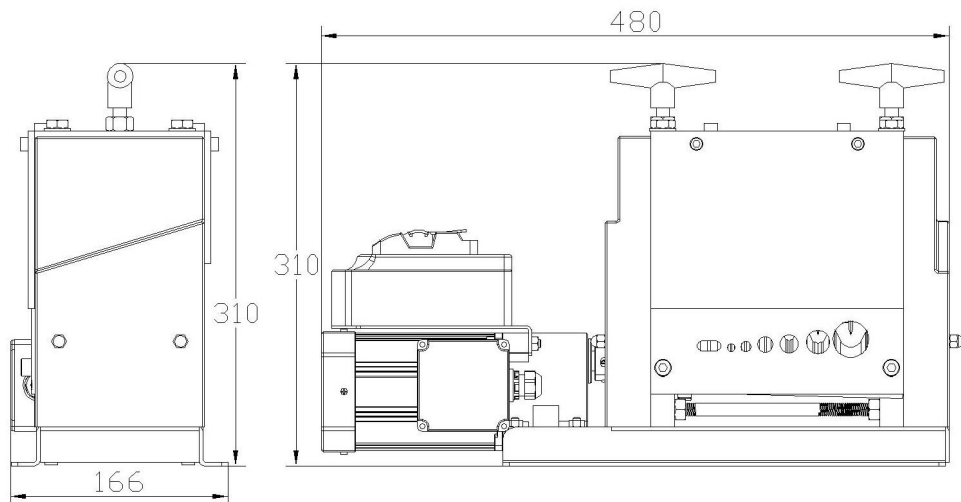

Parts List

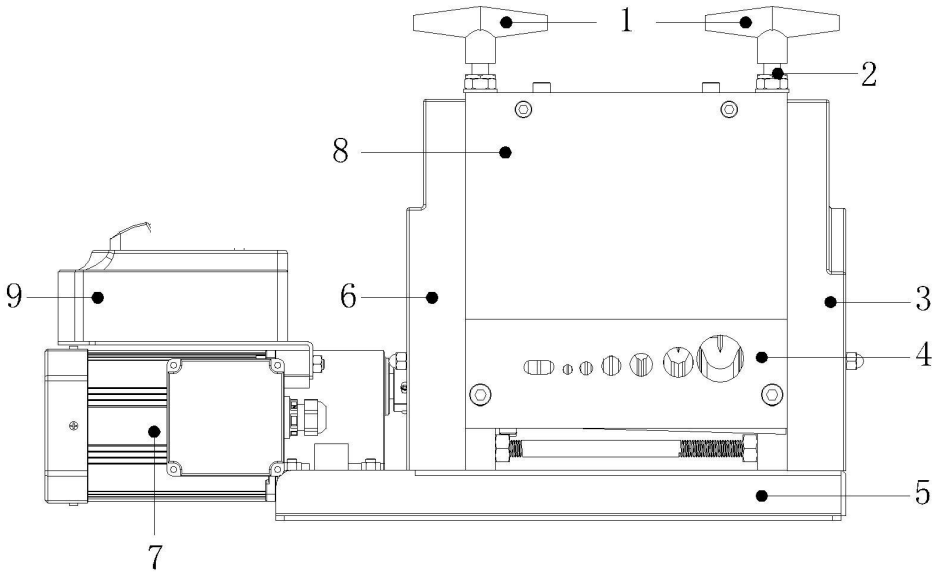

1. M12 Plastic screw
2. Nut for regulating blade up and down
3. Right cover
4. Transparent incoming Panel
5. Baseplate
6. Left cover
7. Motor
8. Front Panel

Accessories

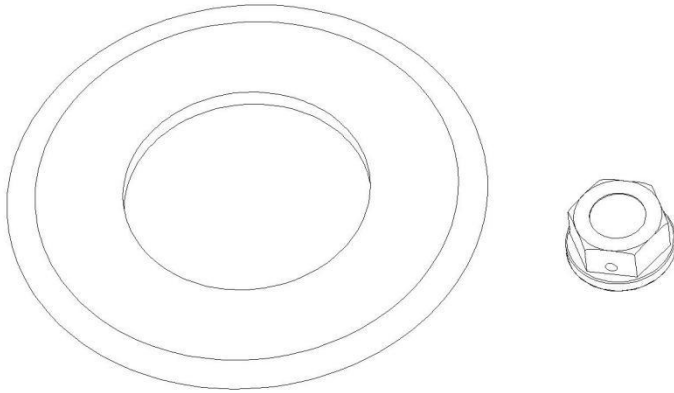

Details:

1. One blade
2. Plastic exhaust nut of reducer

Operation Instruction

1. Select the appropriate feeding hole according to the wire diameter.

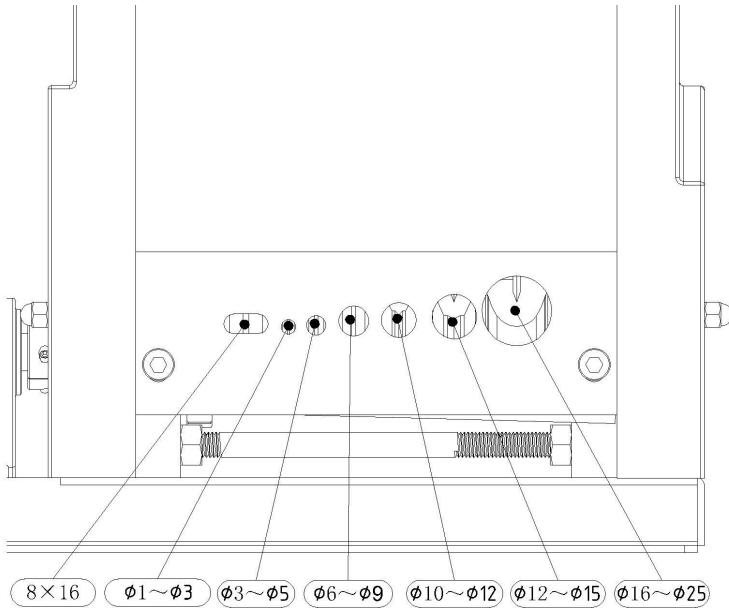

2. During wire stripping, the center of the blade must be collinear with the center of the roller.

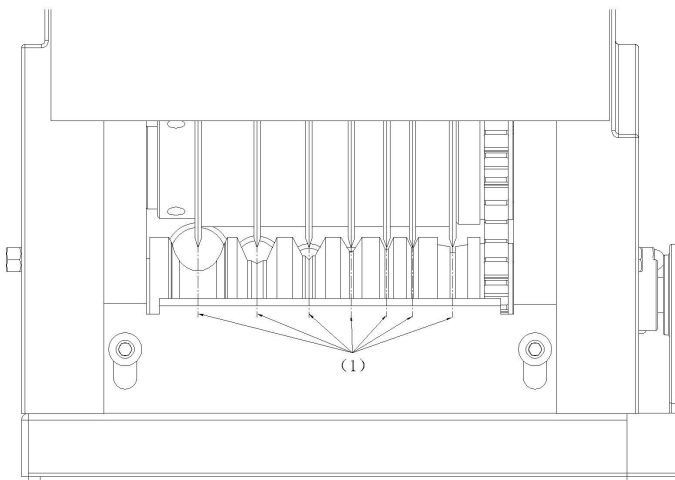

3. According to the thickness of the wire, adjust the distance between blade and rolling shaft so that the blade can cut the wire skin without damaging the copper core. Adjust the M12 plastic handle screw to adjust the height of the blade through the spring assembly. It would be better to make the blade can cut the wire skin without damaging the copper core.

(4) Blade

(5) Rolling shaft

(as shown in the following figure)

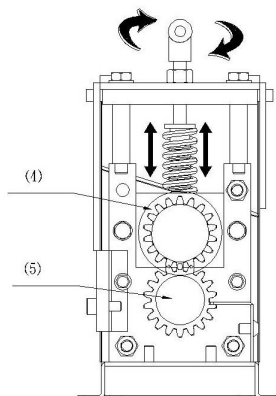
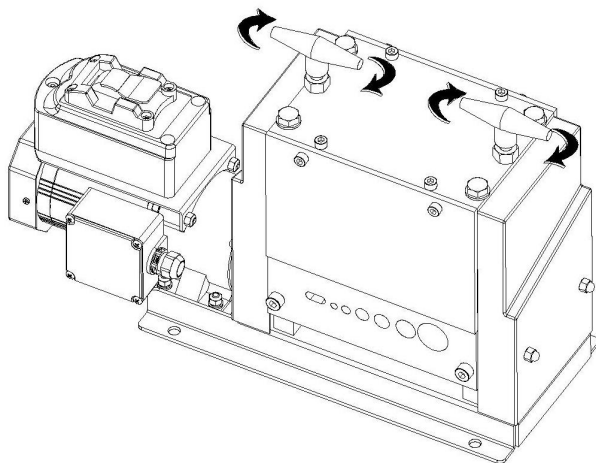
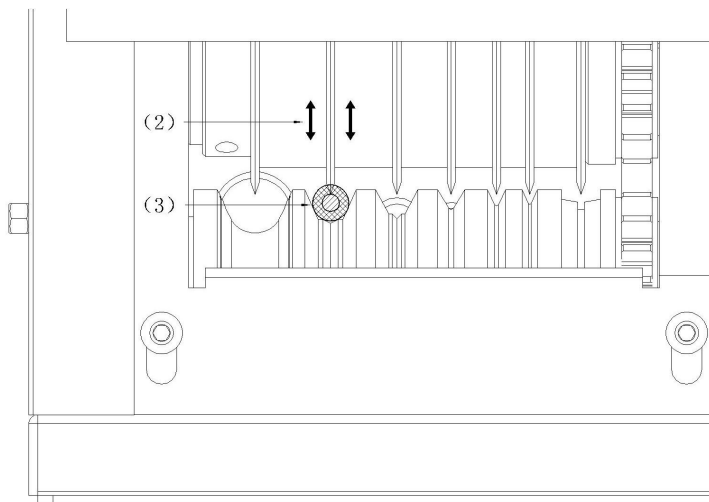

4. If the machine cannot strip the wire, there may be several reasons:

- ① The diameter of the stripped wire is too small. The center of the blade is not on the same line with center of the rolling shaft.

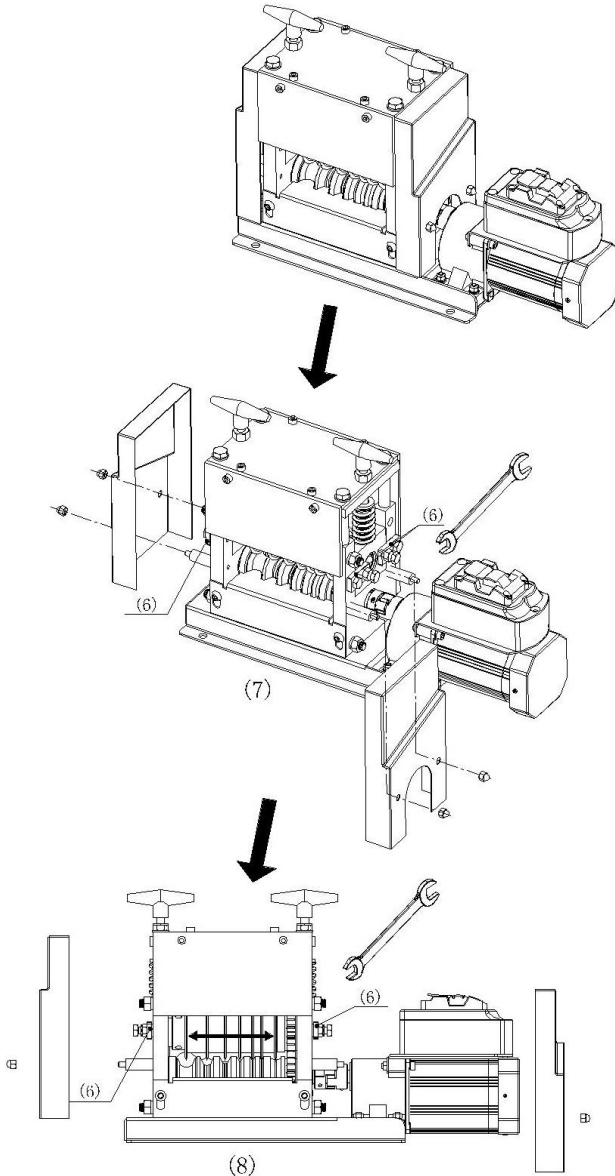

- (6) Center adjustment block for blade
- (7) Remove the shield on both sides of the machine
- (8) Use a wrench to adjust the screw on the center adjustment block to make blade is on the same line of the center of rolling shaft

②The blade is not sharp.

Please follow the operating instructions to replace the sharp blade.

ENVIRONMENTAL PROTECTION

This product is subject to the provision of European Directive 2012/19/EC. The symbol showing a wheelie bin crossed through indicates that the product requires separate refuse collection in the European Union. This applies to the product and all accessories marked with this symbol. Products marked with this symbol cannot be discarded with normal household waste but must be taken to an electrical and electronic equipment collection point for recycling.



MADE IN CHINA

VEVOR[®]

TOUGH TOOLS, HALF PRICE

Technical Support and E-Warranty Certificate www.vevor.com/support