

VEVOR[®]

TOUGH TOOLS, HALF PRICE

Support and E-Warranty Certificate

<https://www.vevor.com/support>

FIREWOOD RACK USER MANUAL

We continue to be committed to offering tools at competitive prices. "Save Half", "Half Price", or any other similar expressions used by us only represent an estimate of savings you might benefit from buying certain tools with us compared to the major top brands and do not necessarily mean to cover all categories of tools offered by us. You are kindly reminded to verify carefully when placing an order with us if you are saving half in comparison with the top major brands.

VEVOR[®]

FIREWOOD RACK

MODEL:HR-CHJ-017

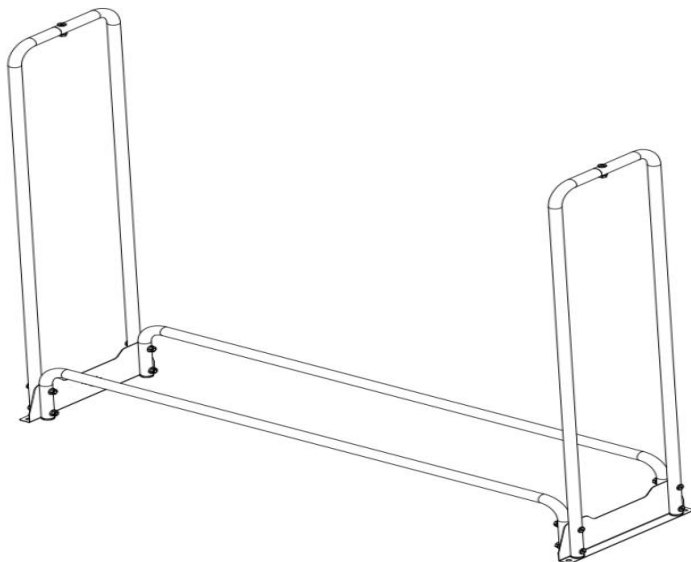

NEED HELP? CONTACT US!

Have product questions? Need technical support? Please feel free to contact us:

 CustomerService@vevor.com

This is the original instruction, please read all manual instructions carefully before operating. VEVOR reserves a clear interpretation of our user manual. The appearance of the product shall be subject to the product you received. Please forgive us that we won't inform you again if there are any technology or software updates on our product.







Attention:

1. Please ensure that the assembly is correct and there is no damage before use.
2. Please install on flat ground to avoid any damage or other problems.
3. For safety, please wear gloves when assembling, using, and disassembling.
4. After placing firewood on, please ensure stability and balance.
5. Do not deliberately press and knock to avoid deformation and damage to the rack.
6. To prevent product rollover, the rack shall be placed on a level and firm ground and fixed to the ground with screws.
7. The screws we provided are only suitable for the concrete floor. The screws for mounting on other ground need to be prepared by the user.
8. Firewood should be stacked in a stable balance to avoid slip and injury.

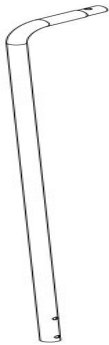
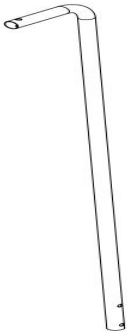
Product Series Form :

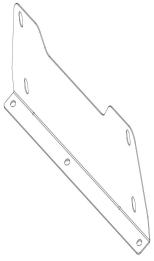
Model / Specification	HR-CHJ-017	HR-CHJ-018	HR-CHJ-019
length	52"	102"	152"
Gross Weight	8.1kg / 17.8lbs	11.2kg / 24.7lbs	14.2kg / 31.3lbs
Package Size	1290×225×80mm / 50.8×8.86×3.15 inch	1308×256×80mm / 51.5×10.1×3.15 inch	1310×256×105mm / 51.6×10.1×4.13 inch
Ground Clearance	> 140mm	> 140mm	> 140mm
Load Limit	200kg	300kg	400kg
Surface finish	Black/Powder coated	Black/Powder coated	Black/Powder coated

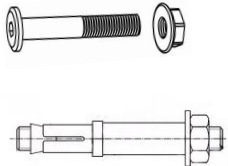
Package List:

			
L frame-A*2pcs	L frame-B*2pcs	U connectors*2pcs	L connection pad*2pcs
			
M8*60mm(8pcs)	M8*35mm (2pcs) M6*50mm (2pcs)	Wrench*1	Cover*1

Assembly Steps:

1. Please connect L frames A & B with M8*35mm screws and nuts to complete the side frame. As the picture shows:

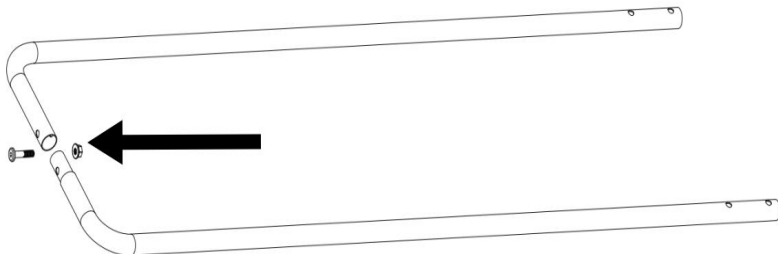

2. Please install the U connector with the side frame, and screw on with the pad by 4pcs M8*60mm screws. As the picture shows:

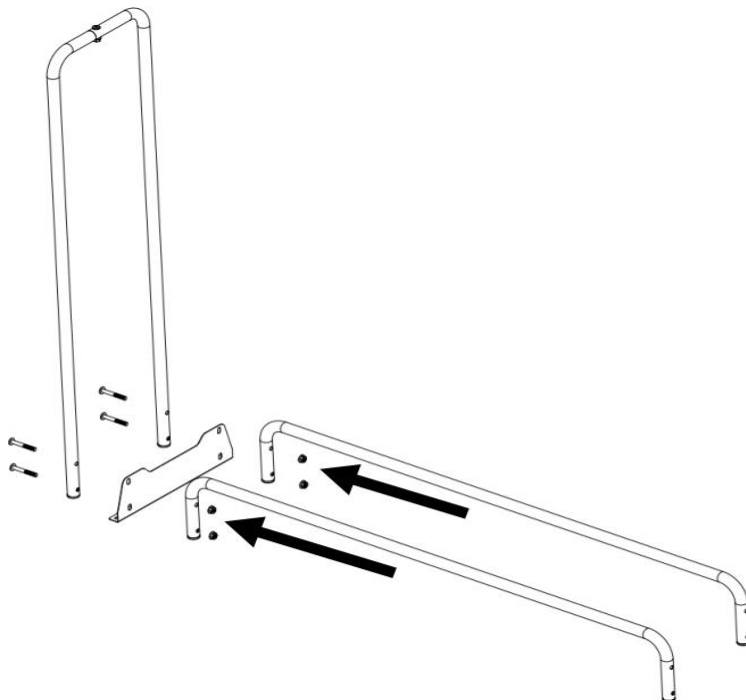

3. Please install another side frame with the same way, and connected with base frame by 4pcs M8*60mm screws. As the picture shows:

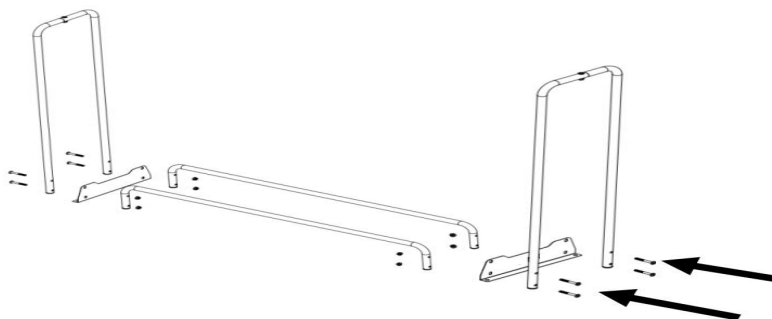

4. After assembly is completed, the L-shaped connection pad is fixed with expansion screws in the middle to increase the stability of the rack. The holes on the side of the connection pad are pre-drilled and can be fixed freely as required. As the picture shows:

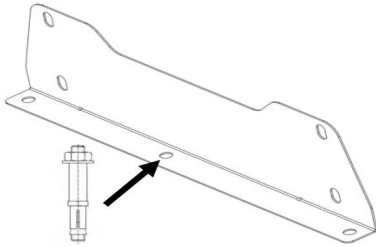

5. Please check and make sure all screws and accessories are not missing and the assembly is not loose or abnormal. The waterproof cover can protect the wood from rain and keep it dry for getting ready to burn.

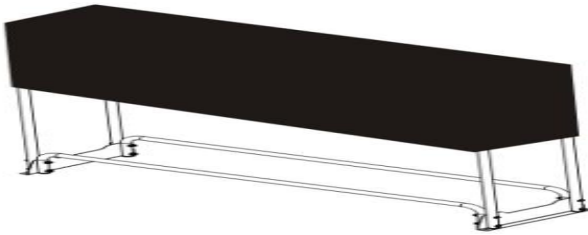

Manufacturer: Huizhou Haorui Hardware Technology Co., Ltd

Add: Hongtian Village, Xinxu Town, Huiyang Dist., Huizhou, Guangdong, China

EC Importer: WAITCHX

Address: 250 bis boulevard Saint-Germain 75007 Paris

UK Importer: FREE MOOD LTD

Address: 2 Holywell Lane, London, England, EC2A 3ET

Made in China

VEVOR[®]

TOUGH TOOLS, HALF PRICE

Support and E-Warranty Certificate

<https://www.vevor.com/support>