

VEVOR[®]

TOUGH TOOLS, HALF PRICE

Technical Support and E-Warranty Certificate www.vevor.com/support

DIAMOND CORE DRILL USER MANUAL

We continue to be committed to provide you tools with competitive price.

"Save Half", "Half Price" or any other similar expressions used by us only represents an estimate of savings you might benefit from buying certain tools with us compared to the major top brands and does not necessarily mean to cover all categories of tools offered by us. You are kindly reminded to verify carefully when you are placing an order with us if you are actually saving half in comparison with the top major brands.

VEVOR[®]

TOUGH TOOLS, HALF PRICE

DIAMOND CORE DRILL

MODEL:Z1Z-9230

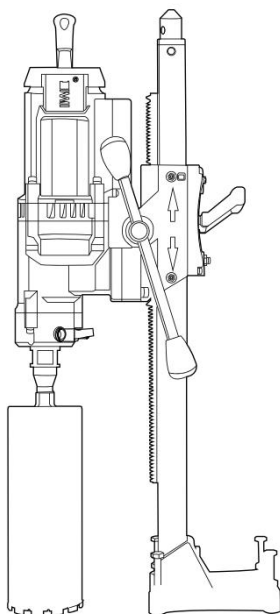

NEED HELP? CONTACT US!

Have product questions? Need technical support? Please feel free to contact us:

✉ CustomerService@vevor.com

This is the original instruction, please read all manual instructions carefully before operating. VEVOR reserves a clear interpretation of our user manual. The appearance of the product shall be subject to the product you received. Please forgive us that we won't inform you again if there are any technology or software updates on our product.



The symbols used in this manual are intended to alert you of the possible risks. Please fully read the safety signs and instructions below.

The warning themselves do not prevent the risks and can not be a substitute for proper methods of avoiding accidents.



This symbol, placed before a safety comment, indicates a kind of precaution, warning, or danger. Ignoring this warning may lead to an accident. To reduce the risk of injury, fire, or electrocution, please always follow the recommendations shown below.



WARNING- To reduce the risk of injury, users must read the instruction manual carefully.

Please refer to the appropriate section in this user manual before any operation.



Warning- Be sure to wear eye protectors when using this product.



WARNING- Be sure to wear dust masks when using this product.



Warning- Be sure to wear ear protectors when using this product.



This product is subject to the provision of European Directive 2012/19/EC. The symbol showing a crossed-out wheeled bin indicates that the product requires separate refuse collection in the European Union. This symbol applies to the product and all accessories marked with this symbol. Products marked as such may not be discarded with normal domestic waste, but must be taken to a collection point for recycling electrical and electronic devices.



This device complies with Part 15 of the FCC Rules. Operation is subject to the following two conditions:(1) This device may not cause harmful interference,and (2) this device must accept any interference received, including interference that may cause undesired operation.



This product is of protection class II. That means it is equipped with enhanced or double insulation.

Please read these instructions carefully before using.



WARNING! To reduce the risk of injury, user must read instruction manual

1. General Power Tool Safety Warnings



WARNING Read all safety warnings and all instructions. *Failure to follow the warnings and instructions may result in electric shock, fire, and/or serious injury.*

Save all warnings and instructions for future reference.

The term "power tool" in the warnings refers to your mains-operated (corded) power tool or battery-operated (cordless) power tool.

1) Work area safety

- a) **Keep work area clean and well lit.** *Cluttered or dark areas invite accidents.*
- b) **Do not operate power tools in explosive atmospheres, such as in the presence of flammable liquids, gases or dust.** *Power tools create sparks which may ignite the dust or fumes.*
- c) **Keep children and bystanders away while operating a power tool.** *Distractions can cause you to lose control.*

2) Electrical safety

- a) **Power tool plugs must match the outlet. Never modify the plug in any way. Do not use any adapter plugs with earthed (grounded) power tools.** *Unmodified plugs and matching outlets will reduce risk of electric shock.*
- b) **Avoid body contact with earthed or grounded surfaces, such as pipes, radiators, ranges and refrigerators.** *There is an increased risk of electric shock if your body is earthed or grounded.*
- c) **Do not expose power tools to rain or wet conditions.** *Water entering a power tool will increase the risk of electric shock.*
- d) **Do not abuse the cord. Never use the cord for carrying, pulling or unplugging the power tool. Keep cord away from heat, oil, sharp edges or moving parts.** *Damaged or entangled cords increase the risk of electric shock.*
- e) **When operating a power tool outdoors, use an extension cord suitable for outdoor use.** *Use of a cord suitable for outdoor use reduces the risk of electric shock.*
- f) **If operating a power tool in a damp location is unavoidable, use a residual current device (RCD) protected supply.** *Use of an RCD reduces the risk of electric shock.*

3) Personal safety

- a) **Stay alert, watch what you are doing and use common sense when operating a power tool. Do not use a power tool while you are tired or under the influence of drugs, alcohol or medication.** *A moment of inattention while operating power tools may result in serious personal injury.*

b) Use personal protective equipment. Always wear eye protection. *Protective equipment such as dust mask, non-skid safety shoes, hard hat, or hearing protection used for appropriate conditions will reduce personal injuries.*

c) Prevent unintentional starting. Ensure the switch is in the off-position before connecting to power source and/or battery pack, picking up or carrying the tool.

Carrying power tools with your finger on the switch or energizing power tools with the switch on invites accidents.

d) Remove any adjusting key or wrench before turning the power tool on. *A wrench or a key left attached to a rotating part of the power tool may result in personal injury.*

e) Do not overreach. Keep proper footing and balance at all times. *This enables better control of the power tool in unexpected situations.*

f) Dress properly. Do not wear loose clothing or jewellery. Keep your hair, clothing and gloves away from moving parts. *Loose clothes, jewellery or long hair can be caught in moving parts.*

g) If devices are provided for the connection of dust extraction and collection facilities, ensure these are connected and properly used. *Use of dust collection can reduce dust-related hazards.*

4) Power tool use and care

a) Do not force the power tool. Use the correct power tool for your application. *The correct power tool will do the job better and safer at the rate for which it was designed.*

b) Do not use the power tool if the switch does not turn it on and off. *Any power tool that cannot be controlled with the switch is dangerous and must be repaired.*

c) Disconnect the plug from the power source and/or the battery pack from the power tool before making any adjustments, changing accessories, or storing power tools. *Such preventive safety measures reduce the risk of starting the power tool accidentally.*

d) Store idle power tools out of the reach of children and do not allow persons unfamiliar with the power tool or these instructions to operate the power tool.

Power tools are dangerous in the hands of untrained users.

e) **Maintain power tools. Check for misalignment or binding of moving parts, breakage of parts and any other condition that may affect the power tool's operation. If damaged, have the power tool repaired before use.** Poorly maintained power tools cause many accidents.

f) **Keep cutting tools sharp and clean.** *Properly maintained cutting tools with sharp cutting edges are less likely to bind and are easier to control.*

g) **Use the power tool, accessories and tool bits etc. in accordance with these instructions, taking into account the working conditions and the work to be performed.** *Use of the power tool for operations different from those intended could result in a hazardous situation.*

5) Service

a) **Have your power tool serviced by a qualified repair person using only identical replacement parts.** *This will ensure that the safety of the power tool is maintained.*

2. Diamond Core Drill Safety Warnings

1. **Use auxiliary handles supplied with the tool.** Loss of control can cause personal injury.
2. Consider work area environment: Don't use diamond core drill in damp or wet locations. Don't expose the diamond core drill to rain. Keep the work area well-lit. In particular, no flammable liquids or gases must be present. The series motor produces sparks during regular rotation. The sparks may cause the risk of fire.
3. Grounding of class I tools is necessary while in use to protect you from electric shock. Class I tools are equipped with an approved three-conductor cord and three-prong grounding-type plug. The green/yellow conductor in the cord is the grounding wire, one end of wire is in the grounding sign of outer tool shell, the other end of wire is connected with the ground wire of plug. Never connect the green/yellow wire to a live terminal.

4.  **Warning ! The socket must be fitted with grounding, don't insert class I tools into the socket without grounding.**

5. Use extension cords when tool is used outdoors or indoors, use special extension wire board. Use only three-conductor cord and with reliable grounding.

6. Take care of the downward direction in the high position, safety belt and safety cap, etc., are recommended.
7. In order to avoid unintentional electric shock, please check the grounding condition of electrified body in working area before operating, it is not allowed to operate the tool under the uncertain condition, once the drill bit touched the electrified body in the wall, floorboard or baseboard, the electrified outer shell of drill may cause personal injuries.
8. The safety equipment is recommended when drilling on high the ceiling to avoid the drill core injuring the persons downstairs or damaging the property downstairs.
9. Connecting the soft pipe with the inner diameter Φ 16mm to the adaptor of the valve.
10. Please ensure that there is no water leak so that it will not dampen the motor when you use the liquid and the attachments.
11. Usually inspect the hoses and other critical parts of the tool which could deteriorate. When a water leak appears from the testing hole of the gearbox, you must turn off the tool immediately and then replace the rubber seal.
12. Replacement of the plug or the supply cord shall always be carried out by the manufacturer of the tool or his service organization;
13. Keep liquid clear off the parts of the tool and away from persons in the working area in order that the water can not enter into the electronic equipment of the tool and keep your safety. It must be use catchment set when the machine working with elevation.

3. HANDLING INSTRUCTIONS

1. Check the voltage:

Make sure the voltage is the same as that indicated on the board of the tools, the voltage in the circuits should be kept at +/-5%.

2. How to install bit:

Installing the diamond-thin bit carefully, the end thread shall match with the end output shaft. The end thread should be smeared with grease firstly, after tightening the drill bit, let it idly run, do make sure that its radial motion is corresponds with the general requirement, then you can operate the drill.

3. There should be some water in the water switch of drill.

4. Material:

When drilling on the reinforced concrete, if the drill bit touches the steel bar, the current will suddenly increase, the motor will vibrate, and the bit will be overloaded. At this time, the drill thrust should be reduced properly. The low current will have an adverse effect on the bit speed and the bit. If the gravel falls into the drill or the drill touches the steel bar, the drill can get stuck, causing high current and clutch slip. At this point, close the tool, remove the bit, and clean the chip notch. Wait 3 minutes for the bit to cool and then restart the switch to continue drilling. If the clutch continues to slip, please stop drilling and re-tighten the clutch.

5. Remove drill core:

When the drill bit almost drills through the floorboard or wall etc materials, be careful in reducing its drill speed to avoid drilling forcibly. When drilling again, please shut off the tool, remove the drill bit and clean its wall with water, after cleaning the chip, beat the drill slightly with the wood stick, be careful in removing the drill core and damaging the drill bit, then installing the drilling to continue operating.

6. Keep the motor ventilated and cool down:

During operating the ventilated notch of motor should not be clogged with dirt to avoid the higher temperature affecting the motor's life or burning down the winding.

7. Waterless operation is forbidden:

When operation, there should be plenty of water flow onto the surface of the drill bit to cool down, and the mud can be washed out to avoid damaging the drill bit and sealing washer.

8. Avoid dampening the motor:

Do keep the enclosure of the motor away from the water to avoid reducing its insulating performance or leaking electricity. Only use the machine with the direction of vertical downward!

9. Drill vibrated

The gap between the elevating body and square pipe and rack increased may cause the drill vibration. At this time, please shut off the tool, adjust the track lining or idle wheel on elevating body, and tighten some relative bolts to adjust it to proper gap.

10. When adjusting the speed, you must stop the machine before turning the knob. It is not allowed to turn the knob when the machine is working, otherwise the gear may be damaged.

4. STRUCTURE, FEATURE AND USAGE

Z1Z-9230 is a portable diamond core drill, suitable for diamond bits 20-230mm stand-alone. Equipped with safety friction clutch, it is easy to use, safe and reliable. Using the diamond thin-wall drill bit produced by our company, this equipment can drill a full range of reinforced concrete, brick, and other materials, with no dust, no vibration, high precision, fast drilling speed and other advantages. Widely used in construction, pipeline installation, road, bridge and engineering quality control, sampling and other fields.

5. MAIN TECHNICAL PARAMETER

Model	Z1Z-9230	
Rated voltage	220-230V~ For EU and AUS	120V~ For US
Rated frequency	50 Hz	60 Hz
Rated input power	3200 W	2500W
No – load speed	750r/min	
Max. Drilling Dia.	Φ203 mm	

6. MAINTENANE

1) If the drill has any troubles, please send it to an authorized service center. It is not strictly allowed to dismantle or replace the parts optionally.

2) Please check the electric brush and commutator periodically. When the brush is

worn about 7mm, it must be replaced. Only use the original, otherwise the commutator may be damaged and both brushes must be replaced at the same time. If you find serious sparks or serious wear and burn of the commutator during operation, please check and repair the commutator or replace a new rotor.

3) The drill should be checked and repaired periodically after used for a long time. Items to be checked include: whether the electrical wire is good or not, the grounding is reliable or not, the inner wire, switch and plug works well or not, the insulating resistance of motor is safe or not, the stator and rotor are in short circuit or not, the bolts are loosened or not, please replace the lubricating oil and wearing parts etc.

4) Replace the rubber sealing washer in time. If water is found flowing in from the top of the bit after prolonged use, check and replace the seal gasket immediately. The gear in the gear case can use lubricating oil, if you find some lubricating oil penetrate the mid-cover air port, please replace the rubber sealing oil ring on the rotor spindle. The brand of special lubricating oil is 110# industrial gear oil. It is not allowed to use common engine oil.

5) Keep the drill clean and dry. If not in use, please clean the drill and keep it in a dry and clean place. When removing a drill bit, apply grease to the drill bit's spindle and the drill thread's connection to protect it.

6) Adjust safety clutch (When you find the friction of clutch become too small.

7. SOLUTION TO THE PROBLEMS DURING USING

Problems	Possible Reasons	Solution
Motor doesn't run when connecting power supply	1.Power supply disconnected 2.Switch breaker positioned 3.Brush ill contacting or running out 4.The winding of stator or rotor circuit	1.Check and connect power supply 2.Check and repair switch or replace improperly or ill contacting switch 3.Replace electric brush 4.Check or replace stator & rotor open circuit.

Heavy sparks and ring sparks occur on commutator of motor	<ol style="list-style-type: none"> 1.Rotor winding is on short circuit or open circuit 2.Brush spring positioned improperly or ill contacting 3.Commutator worn seriously 	<ol style="list-style-type: none"> 1.Repair or replace rotor. 2.Adjust the spring pressure 3.Replace a new rotor
Drill vibrated	<ol style="list-style-type: none"> 1.The base fixed loosened 2.The gap between elevating body and square rack largened 3.Elevating body and connecting bolts loosened 	<ol style="list-style-type: none"> 1.Reassemble and fix the frame 2.Adjust the gap 3.Check bolt
Drill speed is slow	<ol style="list-style-type: none"> 1.Drill bit worn 2.Ceiling pouring quality is bad, there are grits or chips in gap 3.Drill vibrated 4.The nuts on the safety friction 	<ol style="list-style-type: none"> 1.Repair or replace drill bit 2.Stop the drill, remove the foreign materials from gap 3.Adjust and tighten connecting bolt. 4.Tightening nuts clutch loosened

8. STANDARD ACCESSORY

1.Electric brush	2 pieces
2.Inner hexagon spanner	3 pieces
3.4.25-inch Drill bit	1 pieces
4.Open-end wrench	1pieces
5.Nose handle	1 pieces
6.Lifting body handle	1 pieces
7.Ejector screw	1 pieces
8.Anti-tipping pressing plate	2 pieces
9.Joystick	1 pieces
10.Fixing handle screw	2 pieces
11.User manual	1 pieces

9. MAIN PART LIST AND THE BREAKDOWN DRAWING

THE PARTS LIST OF Z1Z-9230 ENGINEERING DRILL

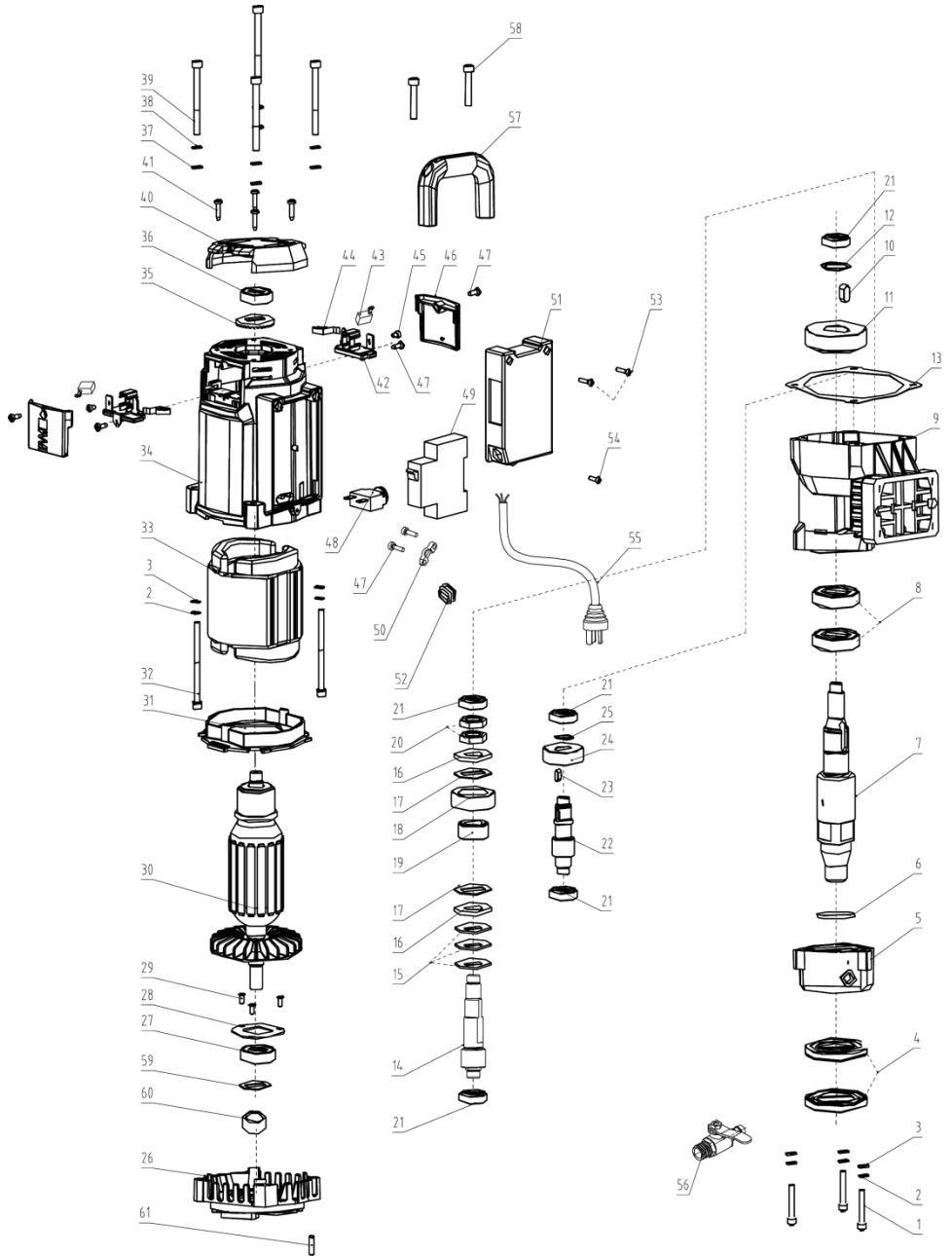

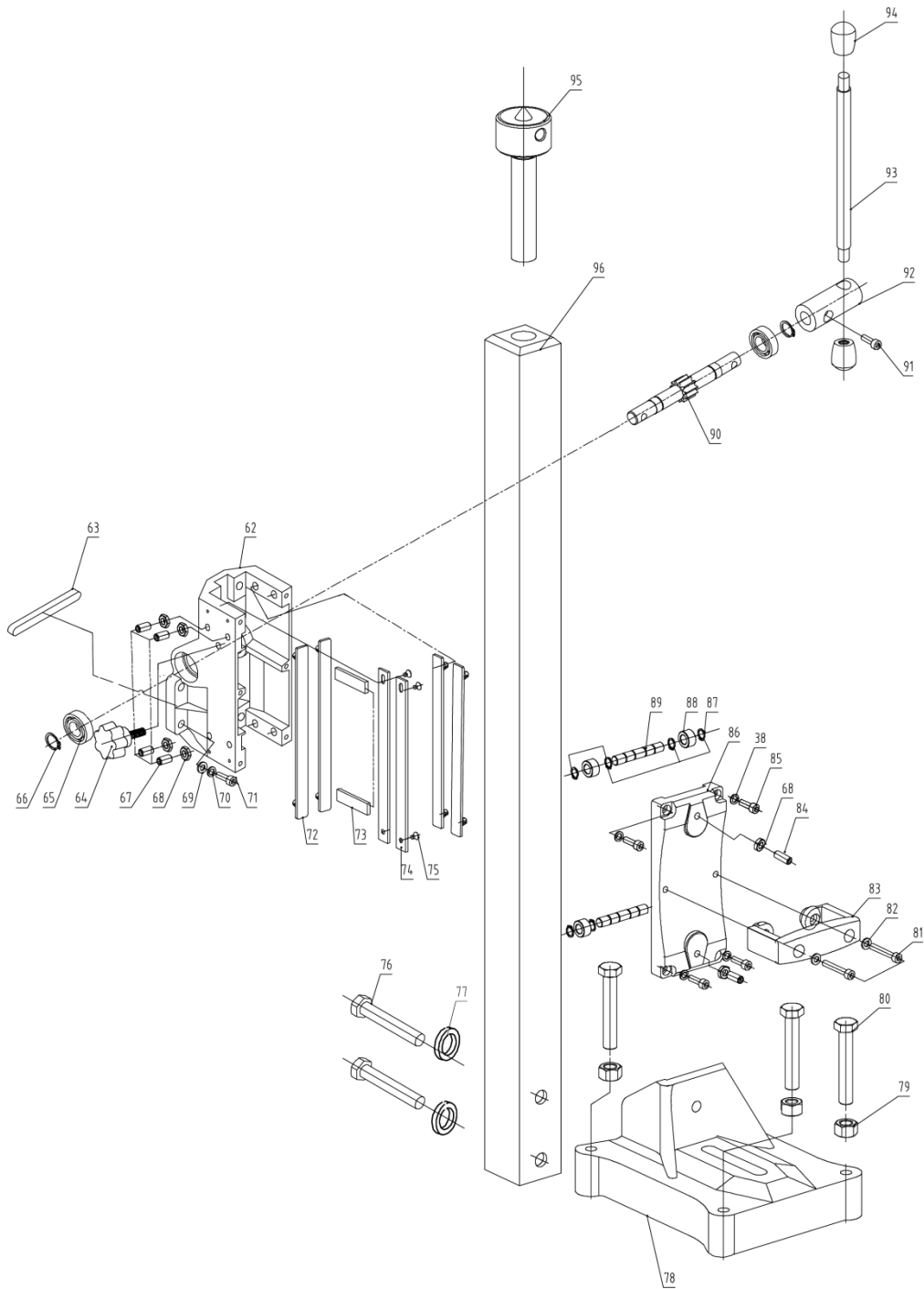

Part list for Z1Z-9230

NO.	Description	Qty	NO.	Description	Qty
1	M5x30 Hexagon socket head cap screw	3	24	2# gear	1
2	Spring washer 5	5	25	Retaining ring for shaft D15	1
3	Flat washer 5	5	26	Middle cover	1
4	Water seal FB38x62x8	2	27	Bearing 6202-2RZ	1
5	Water seal cover	1	28	Bearing pressing plate	1
6	φ38.8xφ3.1xφ45 O-ring	1	29	Cross recessed countersunk head screw M4x10	3
7	Output shaft	1	30	Armature	1
8	Bearing 6005-2RZ	2	31	Shield ring	1
9	Gear box	1	32	M5x85 Hexagon socket head cap screw	2
10	Flat key A8x18	1	33	Stator	1
11	6# gear	1	34	Motor cover	1
12	retaining ring for shaft D25	1	35	Insulating washer	1
13	Gasket	1	36	bearing 6201-2RZ	1
14	5# Gear shaft	1	37	Spring washer 6	8
15	Disk spring	3	38	Flat washer 6	4
16	Retaining ring 18x37.5x3.8	2	39	Hexagon socket head cap screw M6x65	4
17	Friction plate 18x37.5x1.2	2	40	Rear cover	1
18	4# gear	1	41	Cross pan head tapping screw ST4.2x19	4
19	Copper sleeve	1	42	Brush holder assembly	2
20	Hexagon nut M16X1.5	2	43	Carbon brush 8x22	2
21	Bearing 6001-2RZ	5	44	Coil spring	2
22	3# Gear shaft	1	45	Slotted cheese head screw M4x8	2
23	Flat key A5x12	1	46	Carbon brush cover	2

47	Cross pan head tapping screw ST4.2x13	4	69	Flat washer 8	4
48	Circuit protector 12A	1	70	Spring washer 8	4
49	Switch (DELIXI DZ47s D25)	1	71	Hexagon socket head cap screw M8x30	4
50	Cable press board	1	72	Track block 1	2
51	Switch box cover	1	73	Iron track block 1	2
52	Jacket	1	74	Track bar	2
53	Cross pan head tapping screw ST3.5x16	2	75	Cross countersunk head screw M4x6	4
54	Cross pan head tapping screw ST3.5x13	1	76	Hexagon headed bolt M12x65	2
55	Lead & plug 1.5mm ² x2300	1	77	Flat washer 12	2
56	Faucet	1	78	Base	1
57	Handle	1	79	Hexagon nut M12	4
58	M6x35 Hexagon socket head cap screw	2	80	Hexagon headed bolt M12x75	4
59	Washer 18*0.3*34.8	1	81	Hexagon socket head cap screw M6x40	2
60	oil shaker	1	82	Flat washer 6 (out dia. φ12)	2
61	Locating pin φ4x17	1	83	lifting unit handle	1
62	02-205 Lifting unit	1	84	Hexagon socket set screw with flat end M8x20	2
63	Flat key A10x8x100	1	85	Hexagon socket head cap screw M6x20	4
64	Seven-Star handle	1	86	Lifting unit cover	1
65	Bearing 6003	2	87	Shaft ring 10	8
66	Shaft ring 17	2	88	Roller 10*18*10	4
67	Hexagon socket set screw with flat end M8x16	4	89	pin shaft φ10*65	2
68	Hexagon thin copper nut M8	6	90	Operating gear shaft	1

91	Hexagon socket head cap screw M8x25	1	94	Bakelite ball M12	2
92	Operating rod sleeve	1	95	Cap screw	1
93	Rack operating lever	1	96	Column	1

VEVOR[®]
TOUGH TOOLS, HALF PRICE

Technical Support and E-Warranty Certificate
www.vevor.com/support