

VEVOR[®]

TOUGH TOOLS, HALF PRICE

Technical Support and E-Warranty Certificate
www.vevor.com/support

ROUND CHAFING DISH DT-1036 USER MANUAL

We continue to be committed to provide you tools with competitive price.

"Save Half", "Half Price" or any other similar expressions used by us only represents an estimate of savings you might benefit from buying certain tools with us compared to the major top brands and does not necessarily mean to cover all categories of tools offered by us.

You are kindly reminded to verify carefully when you are placing an order with us if you are actually saving half in comparison with the top major brands.

VEVOR[®]

TOUGH TOOLS, HALF PRICE

ROUND CHAFING DISH

DT-1036

Instruction Manual

MODEL NO.: DT-1036

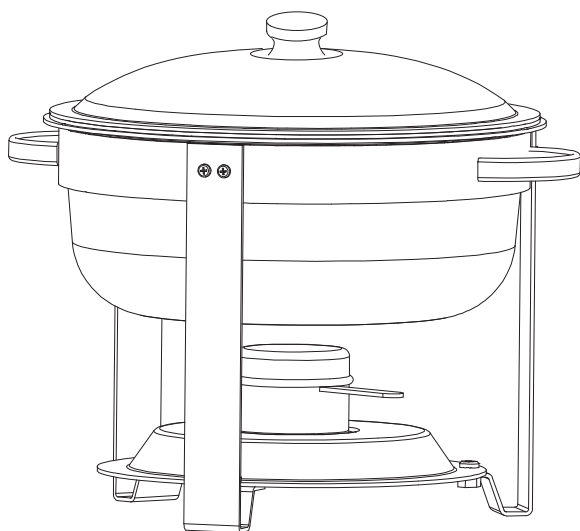

NEED HELP? CONTACT US!

Have product questions? Need technical support?
Please feel free to contact us:

 CustomerService@vevor.com

Note: the quantity of parts shown in the manual is the actual usage and the unused parts are spare parts.

This is the original instruction, please read all manual instructions carefully before operating. VEVOR reserves clear interpretation of our user manual. The appearance of the product shall be subject to the product you received. Please forgive us that we won't inform you again if there is any technology or software updates on our product.





IMPORTANT SAFEGUARDS



1. Children and minors cannot use this product.
2. Only solid fuel can be used as heating fuel. Do not use gasoline, alcohol, etc.
3. Please use the ignition torch to ignite the fuel.
4. When the fuel is burning, special personnel shall be assigned to watch over it to prevent it from being hit or toppled.
5. Close the metal cover of the container to extinguish the fuel. Do not blow it out.
6. It is not allowed to add new fuel before the burning fuel is extinguished and cooled.
7. Remember to clean the food tray and fuel container after each use.
8. Do not clean with corrosive solvents such as strong acid and alkali

Thank you for using this product. In order to make sure that you can operate the machine correctly, read this instruction carefully before operation and keep it properly for future reference. Please be sure to read the precautions and safety rules listed above to ensure your safe use.

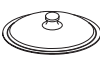
PRODUCT PARAMETERS

For additional information regarding the parts listed below, please refer to the Assembly Diagram of this manual. Unwrap and separate all parts in a clear work area.

NO.	A	B	C	D	E
Name	Food Pan	Water Pan	Lid	Bracket	Fuel Holder
Parts					
Quantity	1 PCS	1 PCS	1 PCS	1 PCS	1 PCS

NO.	F	G	H
Name	Frame	Screw	Tripod
Parts			
Quantity	1 PCS	9 PCS	3 PCS

ASSEMBLY STEPS

STEP 1

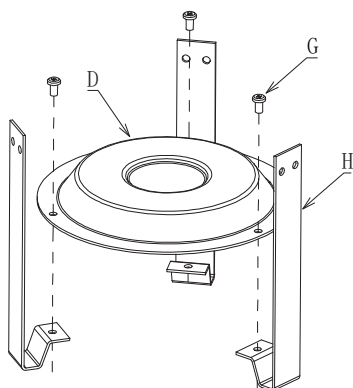

STEP 2

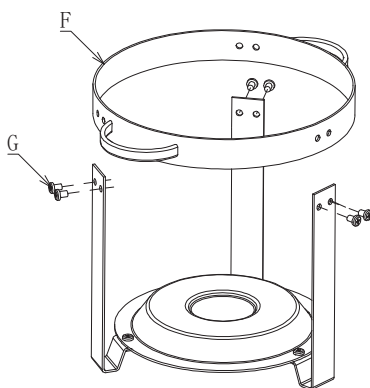

STEP 3

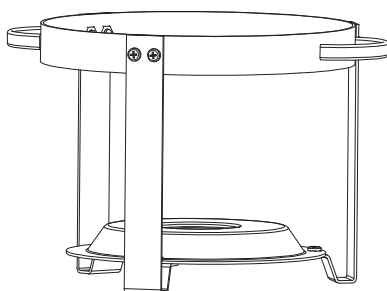

STEP 4

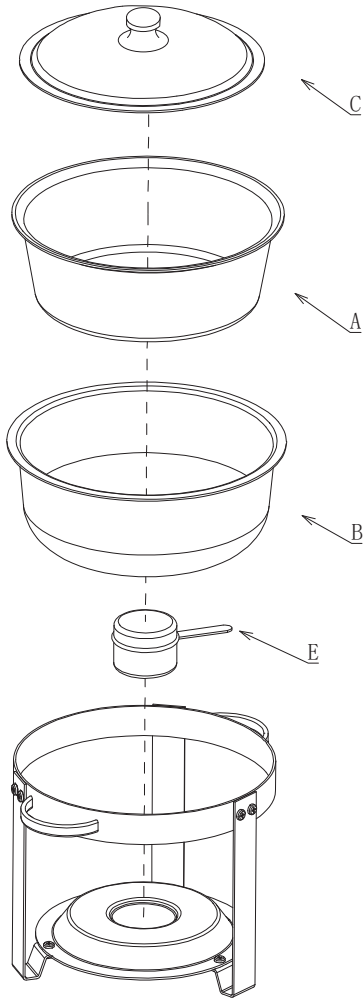

STEP 5

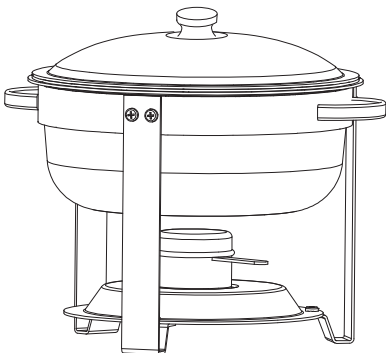

OPERATING INSTRUCTIONS

Before using the product for the first time, peel off any promotional materials and packaging materials, and check that the food pan and water pan are clean and free of dust. If necessary, wipe them over with a damp cloth. Spread over with an absorbent kitchen towel and wipe off any excess oil.

1. Take all the components out of the box and unwrap.
2. Place the frame on a firm surface (see diagram for included parts).
3. Place the fuel holder at the center of the base carefully.
4. Put the water pan into the frame and fill with water (fill in hot water for faster heating).
5. Remove the cover from the fuel holder, and ignite the fuel to heat the water (steam from the heated water will keep the food hot).
6. Place food in the food pan and set this pan into the water pan. The food pan will be suspended above the water. Then, place the cover over the food pan.
7. Replace the cover over the fuel holder to extinguish the burning fuel—DO NOT BLOW IT OUT.

NOTE:

1. Always use a scald-proof pad when touching the fuel holder. Fuel, fuel holder and its cover can get extremely hot.
2. For the best heating efficiency, please keep the lid closed when heating, and check the water level periodically, since the hot water will evaporate into steam.

CLEANING AND MAINTENANCE

1. The frame and cover may be cleaned with warm, soapy water. Never use abrasive materials or scouring pads. Thoroughly wipe off the mild soap instead of immersing the frame into water. If needed, you can polish it with stainless steel cleaner or glass cleaner without ammonia.
2. Parts that can be cleaned in a commercial dishwasher: Food Pan and Water Pan.

Tips

A small plastic rod in the package used to separating these trays.

VEVOR[®]
TOUGH TOOLS, HALF PRICE

Technical Support and E-Warranty Certificate
www.vevor.com/support
Made in China