

VEVOR[®]

TOUGH TOOLS, HALF PRICE

ELECTRIC SCISSOR JACK USER MANUAL

We continue to be committed to provide you tools with competitive price. "Save Half", "Half Price" or any other similar expressions used by us only represents an estimate of savings you might benefit from buying certain tools with us compared to the major top brands and does not necessarily mean to cover all categories of tools offered by us. You are kindly reminded to verify carefully when you are placing an order with us if you are actually saving half in comparison with the top major brands.

VEVOR[®]

TOUGH TOOLS, HALF PRICE

ELECTRIC SCISSOR JACK USER MANUAL

Model: ZS3SJ



NEED HELP? CONTACT US!

Have product questions? Need technical support? Please feel free to contact us:

✉ CustomerService@vevor.com

This is the original instruction, please read all manual instructions carefully before operating. VEVOR reserves clear interpretation of our user manual. The appearance of the product shall be subject to the product you received. Please forgive us that we won't inform you again if there is any technology or software updates on our product.



Safety Warning

1. Please read the "OPERATION MANUAL" carefully and understand all the instruction before operation.
2. Don't move the car while the electric car jack is working works status carefully.
3. Over loading operation is forbidden, without other safety devices.
4. The electric car jack should be placed only on smooth and solid ground. keep you body away from the car while the electric car jack is working.
5. The electric car jack is unsuitable for long continuous operation due to it is machine.
6. It is prohibited to lift the person.
7. Do not overhaul the machine to avoid destroying the machine and lose the right of Guarantee.
8. While taking power directly from the vehicle battery(12V DC power supply) with battery clip, must pay more attention on positive and negative, it can not be wrong, otherwise it will burn electric lifting jack remote control handle.
9. Do not work for long time, when not using, please cut off the power.
10. Avoid the machine dropping into the water and using in the bad condition.
11. Check the power to match well with 12V Car Cigarette Lighter before using.
12. Take notice of the smooth floor and loading capacity when using, also pay attention to finding the exact loading position of the car before the operation of lifting.
13. Do not overload when using the machine, make sure to keep upright with the lifting car at the same time, never operate it aslant.
14. Please check if the name plate and warning indication sticker are in good condition.
15. It can only be used for car maintenance, not for other purposes.

CAUTION: The maximum loading car weight is 3T model !

WARNING

Please pay special attention to the following position which may nip your finger.(FIG1)

ATTENTION

If the electric jack can not work after the car be lifted .you can insert the hand crank into the cover into the cover of gear box to lower the electric jack (FIG2)

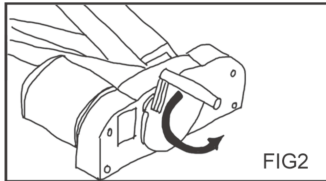
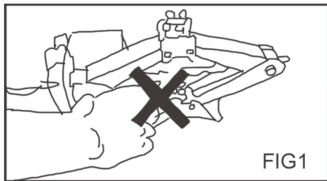

1) Advantages

The machine is with the fashion and beautiful design, and adopts the advanced electric machinery technology. It is low noise, quick speeding, stable lifting performance and so on.

Considering the safety, the machine designs self-locking power structure and Emergency cranking function

That is to say: when the power has been disconnected, the lifted jack will not fall, only re-connecting the power, the jack will go on working, or using the hand wrench to fall the car, which will protect the operator's personal safety effectively.

The machine is widely used for Family Car, Go-anywhere Vehicle, Multi-Purpose Vehicle.

2) Operation Instructions

Warning :please follow the OPERATION MANUAL strictly.

1. When changing tire in an emergency case, warning light up, please park the car on a firm, rigid and flat ground (no more than 6 degrees). pull the brakes, stabilize the tires with tire pads or other anti-skid materials, to make sure the vehicle has been locked safely.

2. The electric lifting jack is connected to the 12V power supply by two ways:

(1) Connected by the cigarette lighter: The lighter plug cable into the car cigarette lighter, the other end of the electric jack into the socket on the control handle. (Note: the cigarette lighter fuse rated current of not less than 12A).

(2) (Recommended) Connected by Vehicle battery directly: When fuse current is less than the fuse within the cigarette lighter. 12A, the lighter plug cord into the cigarette lighter socket with one end of the battery clip, and the clip sandwiching battery red "+" on the (positive) black clip and battery "-" (negative electrode) is connected, and then the other end into the cigarette lighter plug socket on the electric lifting jack control handle. (At this time, the engine of the vehicle should be in working condition)

3. The saddle of the electric car jack should be placed against the right bottom of the car .

4. Press " ^ " on the switchboard and confirm that the saddle is connected with the right bottom position of the car press " ^ " continuously till the car is jacked to and ideal height. (FIG3)

5. Press " v " on the switchboard to lower the car completely after preparing .

6. Press " v " on the switchboard to adjust the position of the electric car jack when the saddle is not touched on the right bottom position of the car .

7. Of course the electric car jack you bought also is equipped with wireless remote control function, you also could select the wireless remote control to operate the rising and descending tasks (the distance within 10m)!

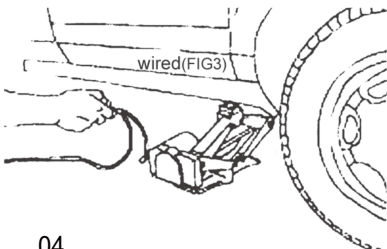

8. Counter-clockwise turning will lower the jack easily . when no power supply.

3) Technical Data

Model	Input Voltage	Rate Current	Rate Power	Max.Loading Car Weight	Lifting Rang	Fuse	Working Temperature
ZS3SJ	DC12V	15A	180W	3T	12-37/ 17-42cm	15A	-20 ~ +70 ℃

4) Assembly Sketch And Component List

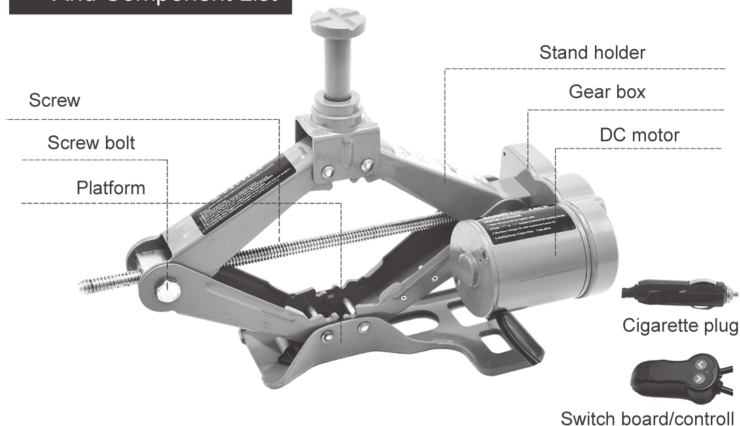

HOW TO REPLACE THE FUSE IN THE 12V PLUG

- 1.To replace the fuse in the plug,twist off the upper cover.
- 2.Remove the faulty fuse and insert a new one.
- 3.Twist the cover back on the plug. A spare fuse is enclosed in the case.



5) Operation Scope

The electric car jack is used for cars.

6) Operation Environment

The electric cart jack is applicable below 5000m sea level and from -20°C to 70°C under natural temperature, it is prohibited to be operated under the circumstances and magnetic and explosive fields.

7) Operation Duration

It is 2 years.

8) Maintenance

The electric cart jack must be maintained and repaired by professionals according to the OPERATION MANUAL

1. Put lubricant on the screw bolt of electric car jack periodically.
2. Keep it clean and dry after operation.
3. Any change in the structure, which might affect its safety is forbidden.

9) Storage

It is stored under the temperature from 0-70°C with humidity less than 70%. To avoid severe collision, upside down and water during transportation.

10) Trouble Analysis

Trouble	Causes	Measure
The electric jack dose not work or the car cannot be jacked up..	A.Overloaded	A.Reduce the weight
	B.No electricity in the lighter	B.Check it or insert the plug correctly
	C.Fuse is broken	C.Chang a good fuse

Package contents

No.	Name	Quantity
1	Electric scissor jack	1
2	Long top head	1
3	Short top head	1
4	Power line(3.5m)	1
5	Hand rocker lever	1
6	Fuse wire	3
7	Glove	1
8	Battery clip	1
9	Carrying case	1
10	User manual	1

Manufacturer: Jinyun Zhaoshi Tool Co.,Ltd
Add: 231 Xianmu West Road, Huzhen Town,
Jinyun County, Lishui City, Zhejiang Province, China

EU Importer: WAITCHX

Address: 250 bis Boulevard Saint-Germain, 75007 Paris, France

UK Importer: FREE MOOD LTD

Address: 2 Holywell Lane, London, England, EC2A 3ET



EUREP GmbH
Unterlettenweg 1a, 85051
Ingolstadt, Germany



EUREP UK LTD
UNIT 2264, 100 OCK STREET, ABINGDON
OXFORDSHIRE ENGLAND OX14 5DH

MADE IN CHINA

VEVOR[®]

Support and E-Warranty Certificate
<https://www.vevor.com/support>

MADE IN CHINA