

**VEVOR<sup>®</sup>**

**Multi-Function  
Digital Heat Transfer Machine**

**USER MANUAL**

# VEVOR<sup>®</sup>

## Inverter Welding Machine

Instruction Manual

TLM13135

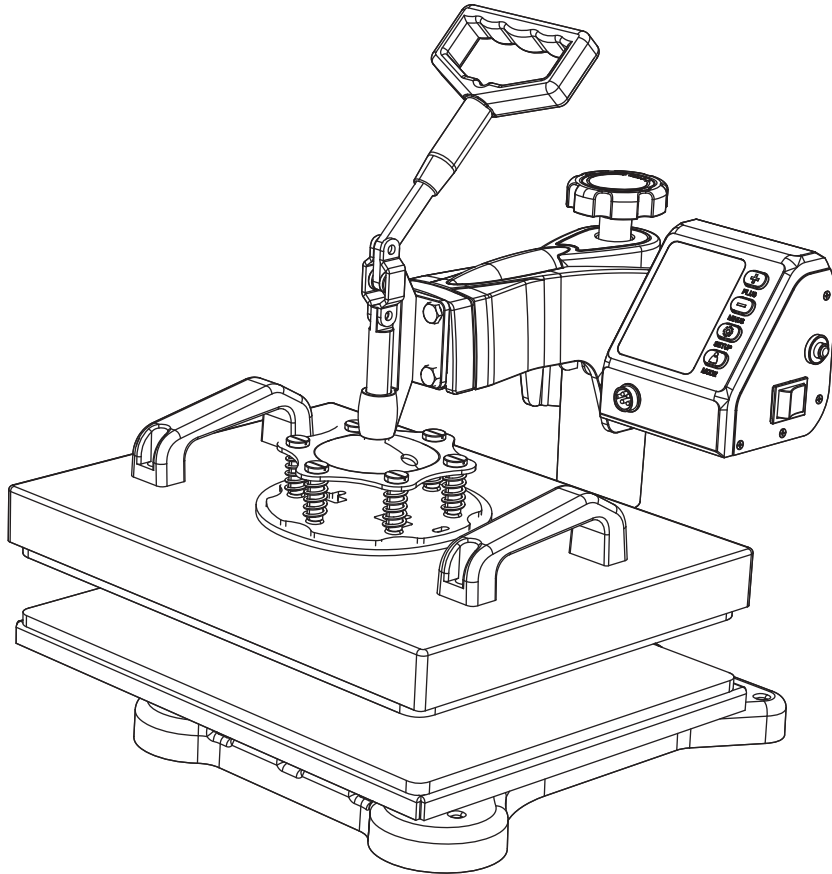

### NEED HELP? CONTACT US!

Have product questions? Need technical support? Please feel free to contact us:

 [CustomerService@vevor.com](mailto:CustomerService@vevor.com)

This is the original instruction, please read all manual instructions carefully before operating. VEVOR reserves clear interpretation of our user manual. The appearance of the product shall be subject to the product you received. Please forgive us that we won't inform you again if there is any technology or software updates on our product.

# CONTENTS

Introduction of Heat Press Machine .....	01
Internal Parts .....	02
Assembly and Disassembly of the Machine .....	02
How to press T-shirts .....	05
Operation of Intelligent Temperature Controller .....	06
Switching between Fahrenheit and Celsius .....	07
Assembly and Uses of Cap Press .....	08
Assembly and Uses of Mug Press .....	10
Assembly and Uses of Conical-shaped Mug .....	11
Assembly and Uses of Plate .....	12
Method of Use .....	14
Warnings .....	15





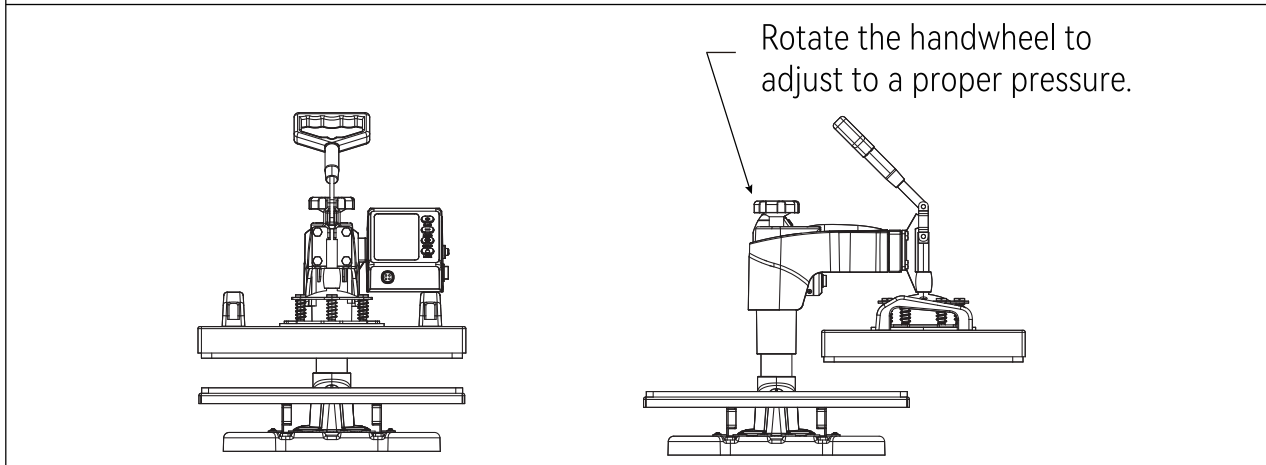
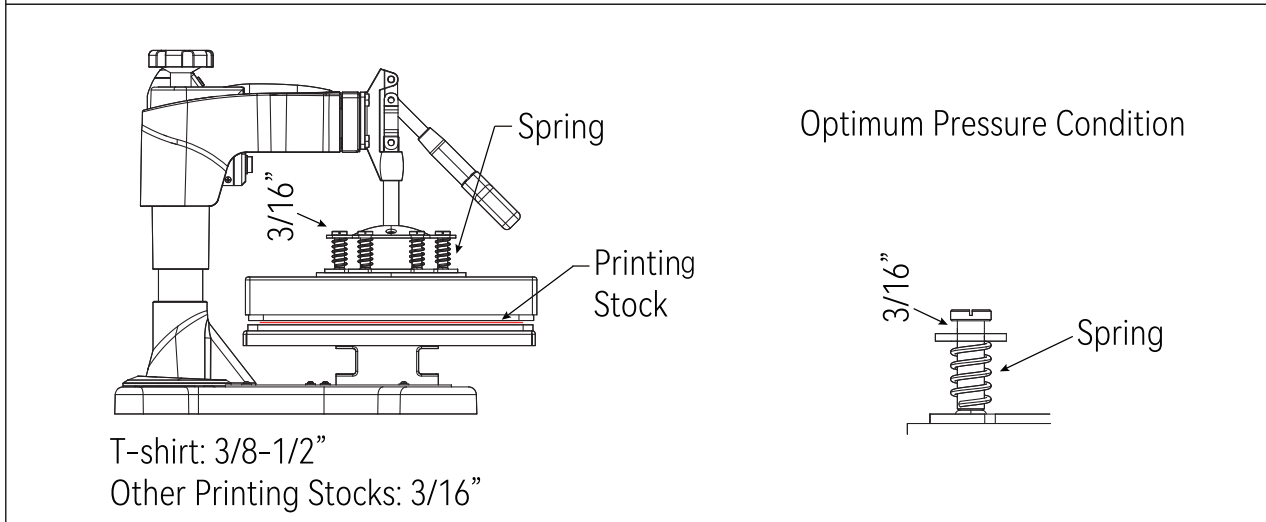
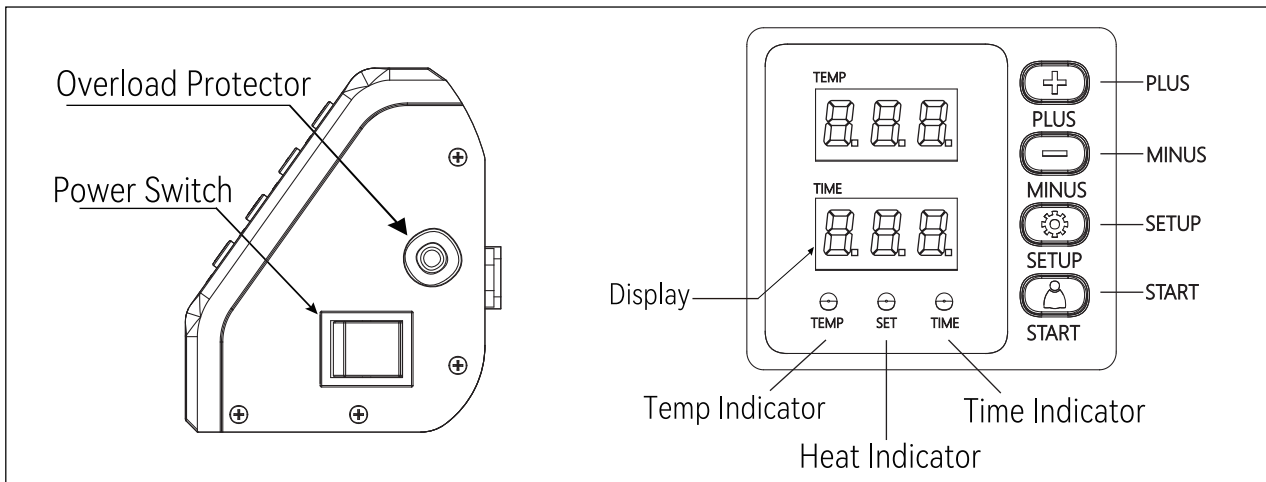

# Introduction of Heat Press Machine

Model	TLM13135
Temperature Range	32 - 450 °F / 0 - 232 °C
Timer Range	0 - 999 S
Rating	120V ~ 50/60Hz 900W For US users
	220-240V ~ 50/60Hz 1250W For European users
Package Size	20.7×17.7×13.4in / 525×450×340mm
Product Weight	34.6 lbs / 15.7 kg

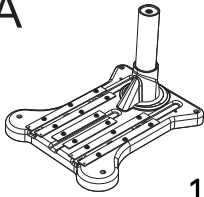
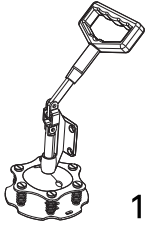
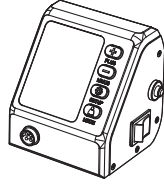
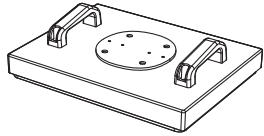
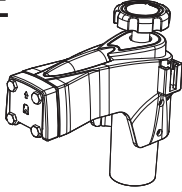
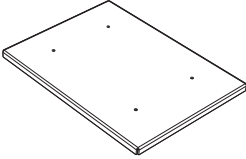
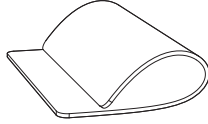
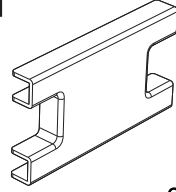
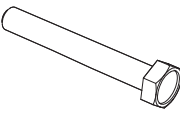

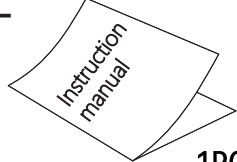

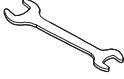
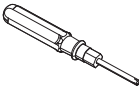
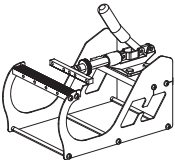
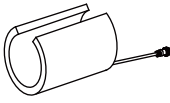
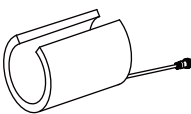
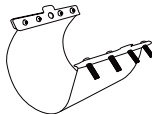
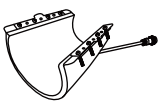
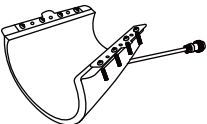
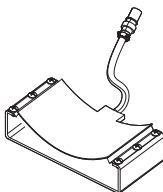
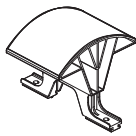
# Internal Parts

<p><b>A</b></p>  <p>1PC</p>	<p><b>B</b></p>  <p>1PC</p>	<p><b>C</b></p>  <p>1PC</p>	<p><b>D</b></p>  <p>1PC</p>
<p><b>E</b></p>  <p>1PC</p>	<p><b>F</b></p>  <p>1PC</p>	<p><b>G</b></p>  <p>1PC</p>	<p><b>H</b></p>  <p>2 PC</p>
<p><b>I</b></p>  <p>4 PC</p>	<p><b>J</b></p>  <p>4 PC</p>	<p><b>K</b></p>  <p>8 PC</p>	<p><b>L</b></p>  <p>1PC</p>
<p><b>M</b></p>  <p>1PC</p>	<p><b>N</b></p>  <p>1PC</p>	<p><b>O</b></p>  <p>1PC</p> <p>You can remove the head of the Phillips screwdriver and turn it 180 degrees to replace it with a flat-head screwdriver.</p>	
<p><b>P</b></p>  <p>1PC</p>	<p><b>Q</b></p>  <p>1PC</p>	<p><b>R</b> Only 8 in 1 Heat Press Has Part C</p>  <p>1PC</p>	<p><b>S</b></p>  <p>1PC</p>
<p><b>T</b> Only 8 in 1 Heat Press Has Part</p>  <p>1PC</p>	<p><b>U</b> Only 8 in 1 Heat Press Has Part</p>  <p>1PC</p>	<p><b>V</b></p>  <p>1PC</p>	<p><b>W</b></p>  <p>1PC</p>
<p><b>X</b></p>  <p>1PC</p>	<p><b>Y</b></p>  <p>1PC</p>		

# Assembly and Disassembly of the Machine

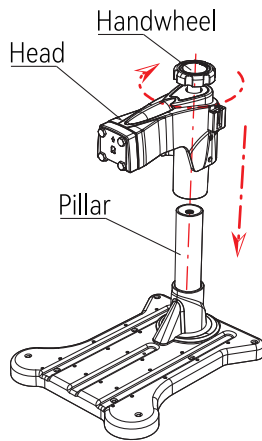

Fig 1

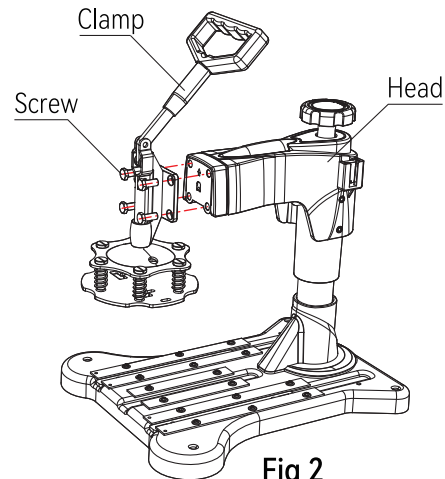

Fig 2

1. Put the head into the pillar and rotate the handwheel 10 times clockwise, which indicates that the head is installed (as shown in fig1).
2. Pass the four screws through the quick clip and adapter, then screw them securely to the machine head, and use a wrench to lock the screws (as shown in figure 2).

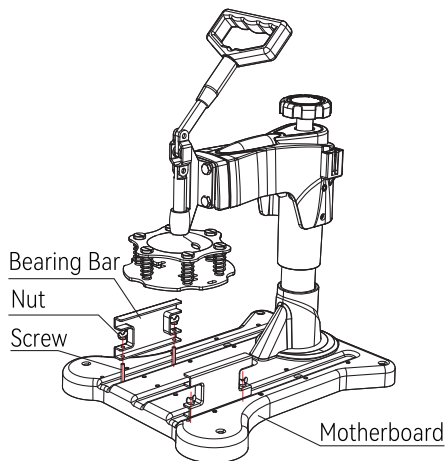

Fig 3

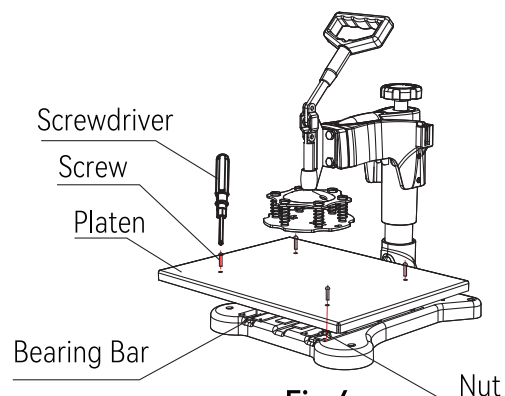

Fig 4

3. Use 4 screws from the bottom up, through the bearing bar from the back of the backplane, and then lock it with hand screws (as shown in figure 3).
4. Place the table platen flat on the bearing bar, align the platen with the hole in the bearing bar, place the screw, and lock it with a screwdriver (as shown in figure 4).

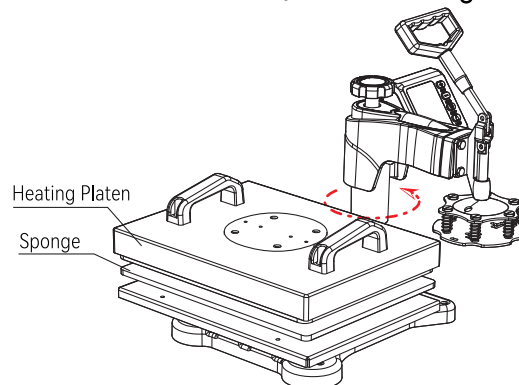
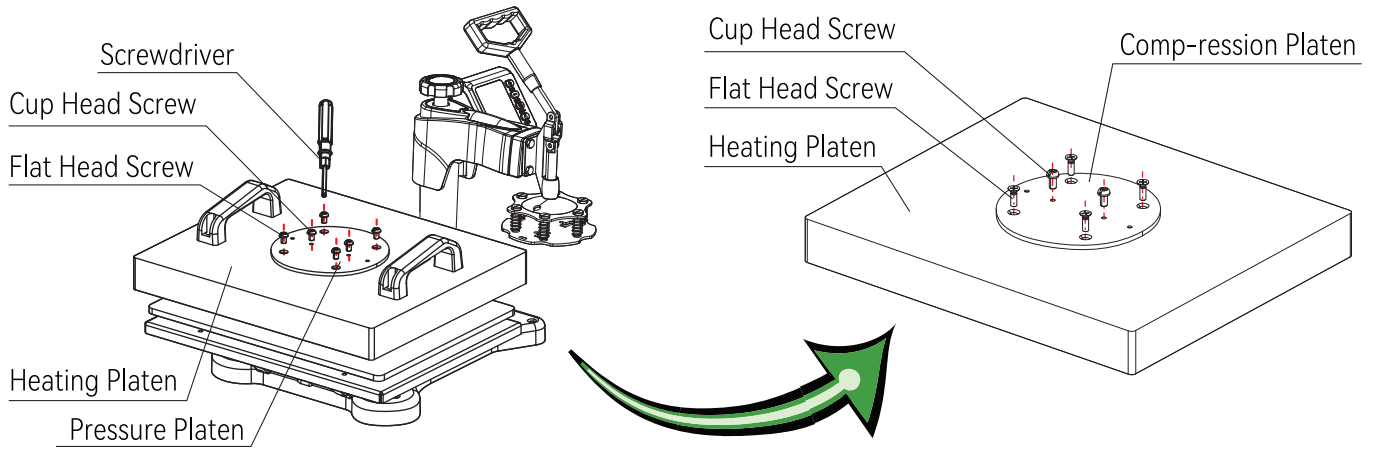

Fig 5

5. Swing the head away and put the sponge and the heating platen on the top of the table platen in order (as shown in figure 5).



**Fig 6**

6. Place the pressure platen flat on the heating platen, align it with the hole, take 4 flat head screws, and tighten them with a screwdriver. Take 2 cup head screws and lock them to the hole in the middle of the pressure platen. at this time, do not lock the cup head screws; reserve 5-7mm for the next installation step (as shown in figure 6).

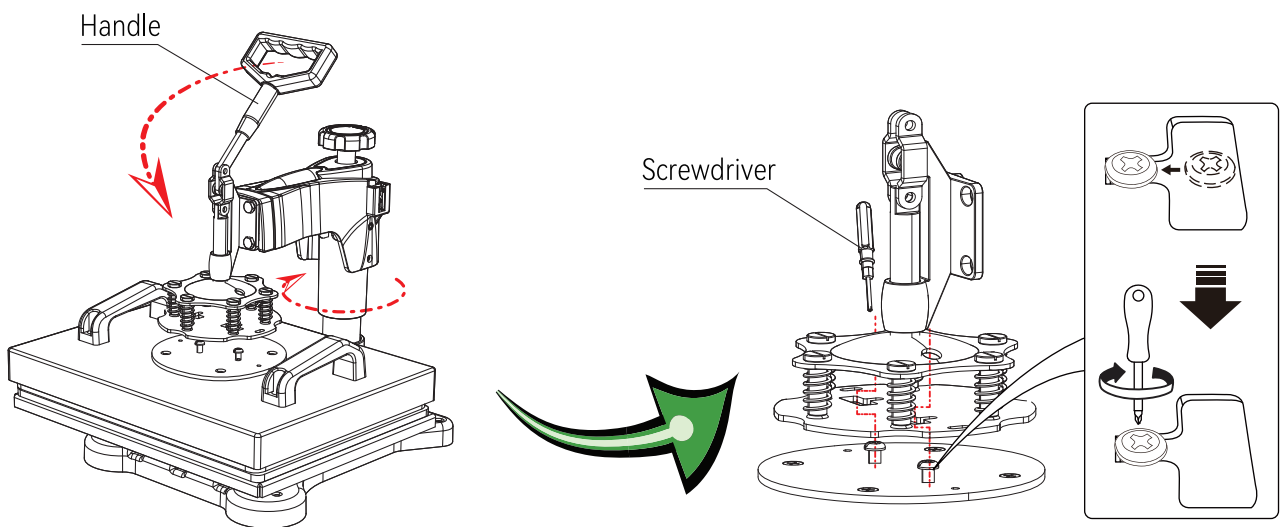

**Fig 7**

7. Rotate the head back to the original position and gently press down the handle so that the cup cap of the cup head screw above the pressure platen snaps into the slot and then lock it in place with a screwdriver (as shown in fig 7).

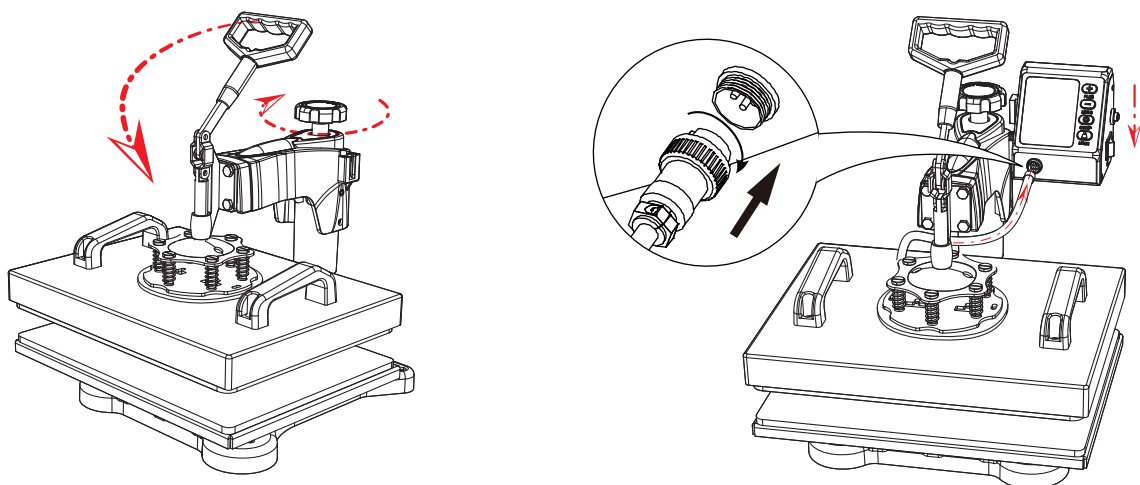

**Fig 8**

**Fig 9**

8. Rotate the handwheel and try to press the handle several times until it is adjusted to the appropriate pressure (as shown in figure 8).
9. Clip the controller into the head slot from top to bottom, connect the male head of the heating platen with the female head of the control controller, and lock the nut to complete the installation (as shown in figure 9).

# How to press T-shirts

1

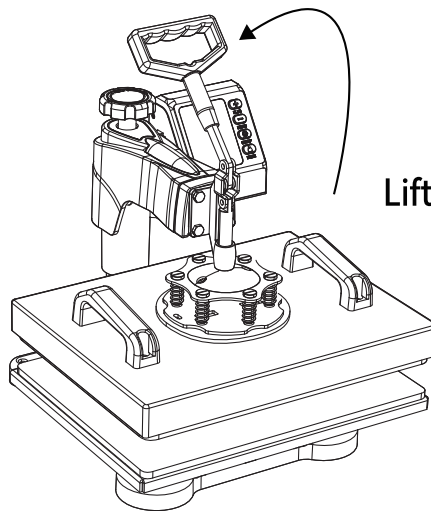

Lift the handle

2

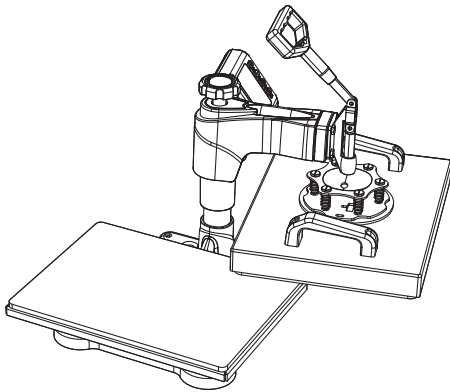

Rotate the heating platen to one side.

3

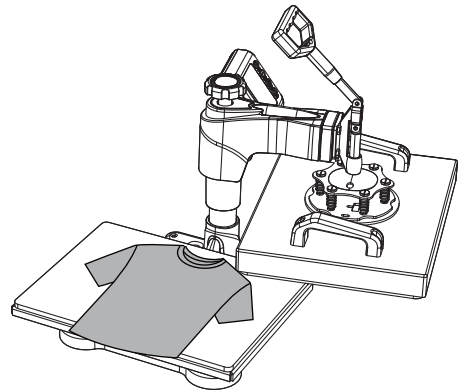

Pull out the lower panel, place the clothes flat on the platen, and place the pattern on the clothes.

4

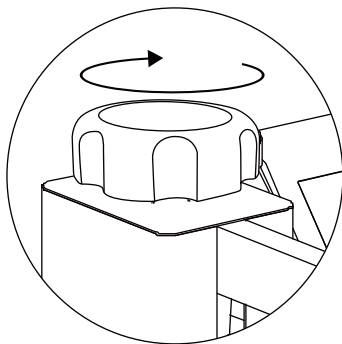

Rotate this switch to adjust pressure

5

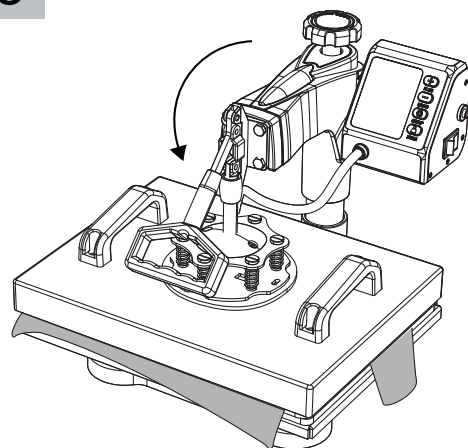

# Operation of Intelligent Temperature Controller

## 1. Prepare Before Use

- a. Check the connection between the power plug of the controller and the electrical socket. Be sure to use a safety grounding wire while operation!
- b. Before turning on the machine, the heating elements must be firmly inserted into the machine. Turn on the power by flipping the ON/OFF switch.  
(Maximum Voltage: 220V; Input Power: 1250W).

## 2. Temperature Set Requirement

Please set the temperature and time according to the following table :

Objects	Temperature ( °F )	Recommended Heating Time (s)
Cup	330	40
Ceramics	330	40
Metal Board	300	40
Wood	355	150
T-shirt	355	Polyester Materials: 30 - 50
		Cotton Materials: 10 - 20

### 1. Heating Temperature Setting ( Range: 0-450°F )

Press the "SETUP" button once. The Temp light will turn into red. Then press the "+/- key" to set the heating temperature.

### 2. Heating Time Setting ( Range: 0-999s )

Press the "SETUP" button a second time. The Time light will turn red. Then press the "+/- key" to set the heating time.

### 3. Finish Setup and Prepare to Work

Press the "SETUP" button a third time to finish setting. The indicator will be on, and the temperature continues to rise. When the set temperature is reached, press  to start a countdown. After the countdown is complete, a "Didi" sound will be heard; the indicator will go out. Lift the handle to take out clothes.

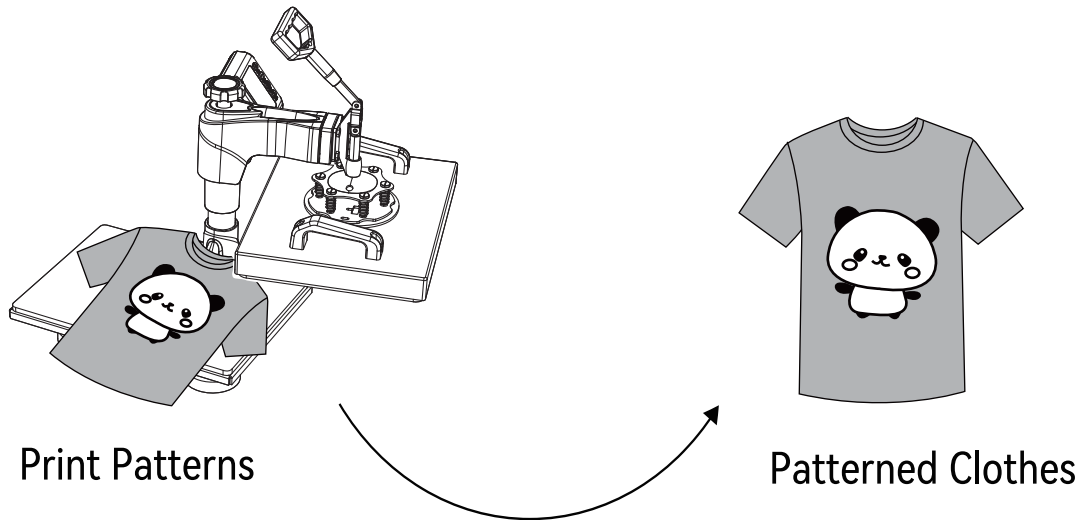

Turn off the power. It is recommended to wear insulation gloves to pull out the accessories or wait for 2-3 minutes.

## Switching between Fahrenheit and Celsius

Long press the "+" and "-" buttons at the same time and wait for 4 seconds until the interface shown in the left picture appears, then click the button "SETUP" to get the interface shown in the right picture, then click the "+" button to set it to Fahrenheit, or click the "-" button to set it to Celsius. Click the "SETUP" button again to exit the temperature switch mode.

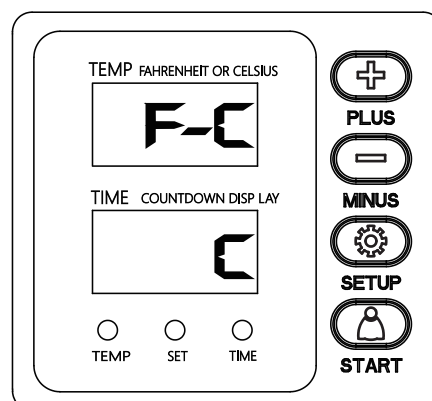
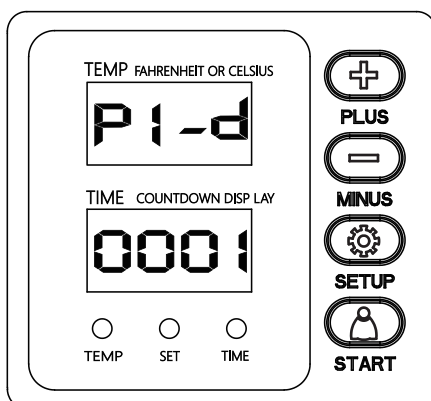

# Assembly and Uses of Cap Press

1

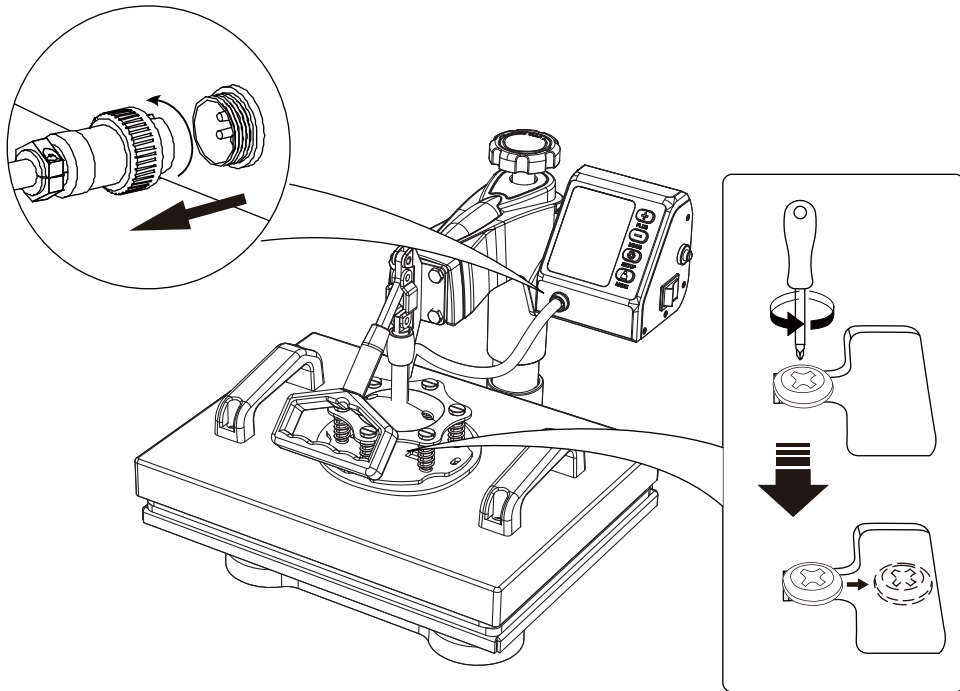

Unplug the Plug

2

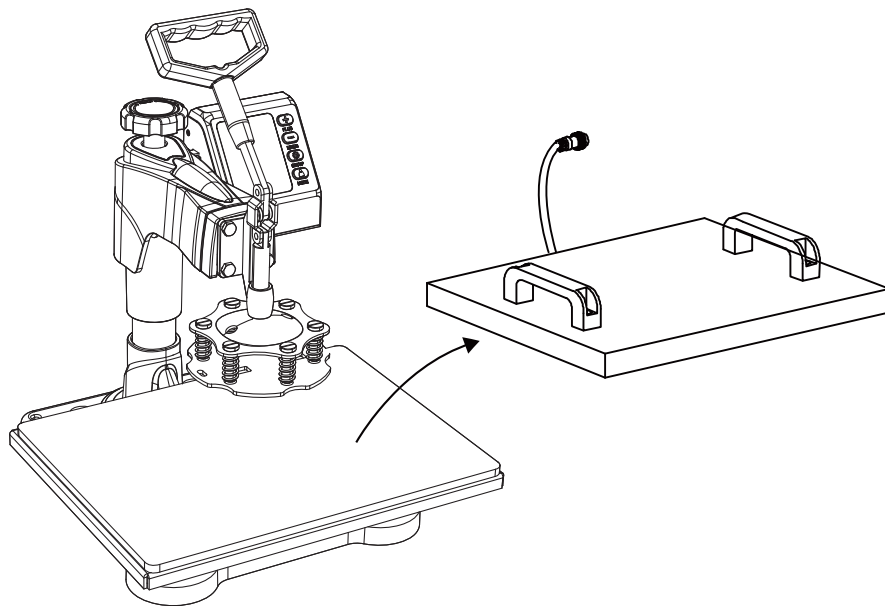

Take out the Heat Platen



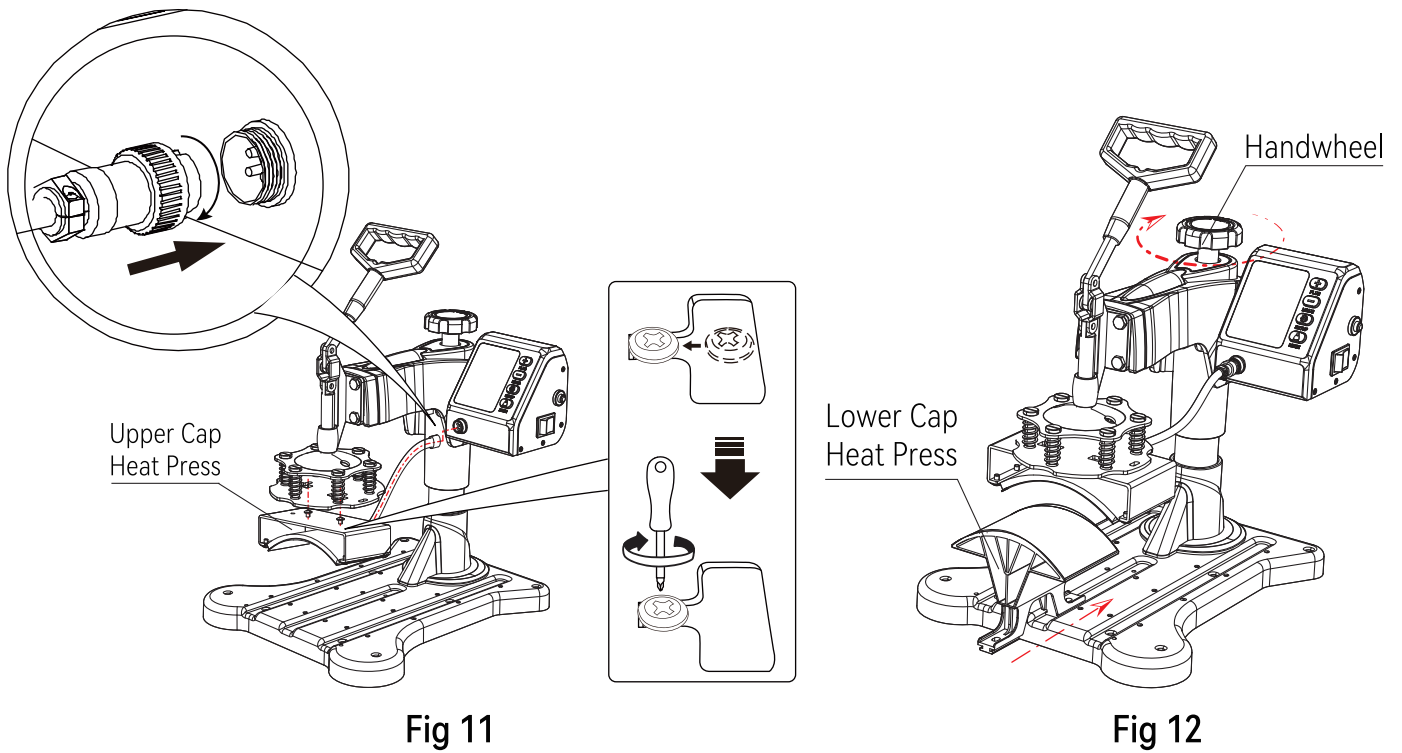
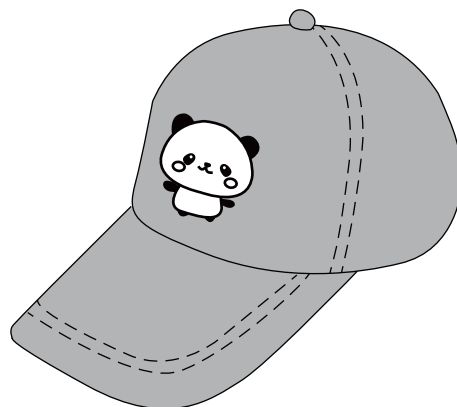

Fig 11

Fig 12

1. Take 2 cup head screws and lock them into the hole in the middle of the cap press. Do not lock the cup head screws, leave 5-7mm, then clip the cup head screw into the slot along the indicated route and lock it with a screwdriver. Insert the male head of the cap press plug into the female head of the controller and tighten the nut (as shown in figure 11).
2. Push the lower cap heat press into the bottom platen along the guide groove. Rotate the handwheel to adjust to an appropriate working pressure (as shown in figure 12).





# Assembly and Uses of Mug Press

1

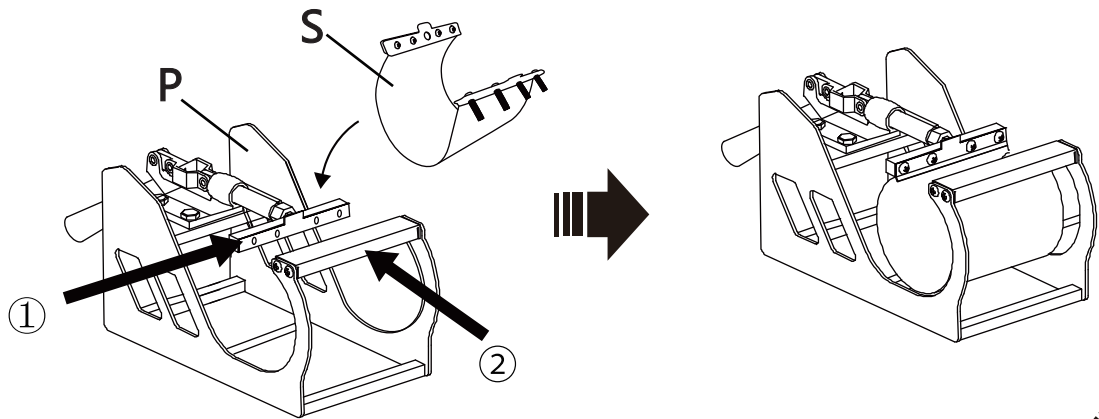

Install S into Part P.  
( We suggest installing the screw at ① first,  
and then installing the screw at ② )

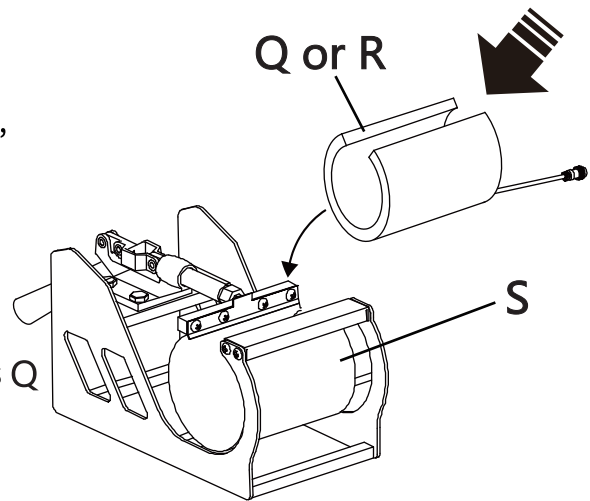

Choose a right size mug press Q  
Put Q or R in part S.

2

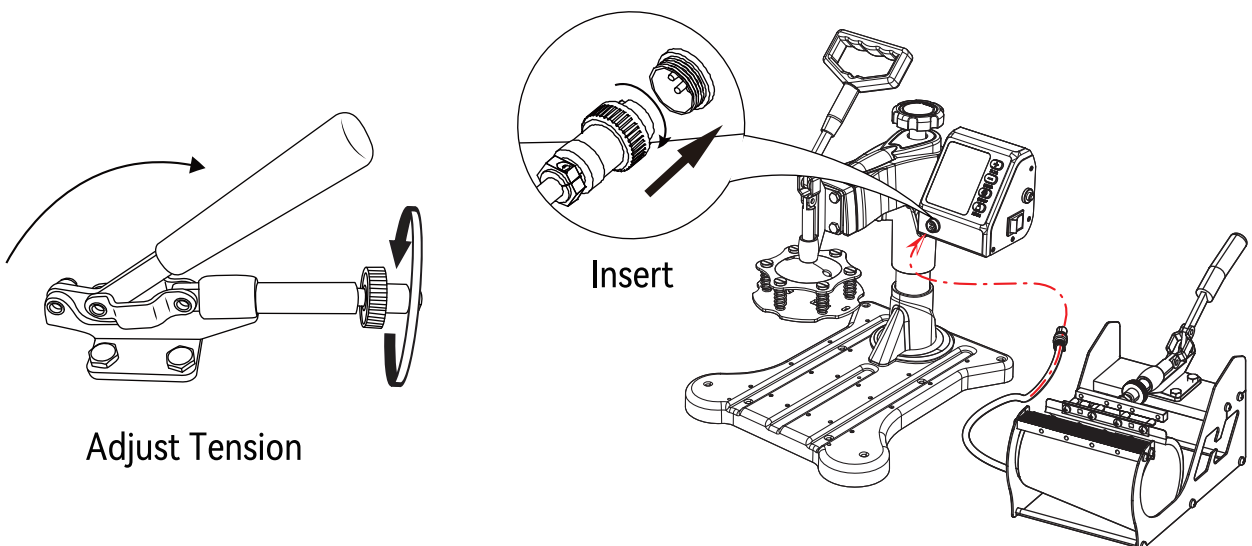

Adjust Tension

Insert



Cylindrical-shaped Mug

# Assembly and Uses of Conical-shaped Mug

1

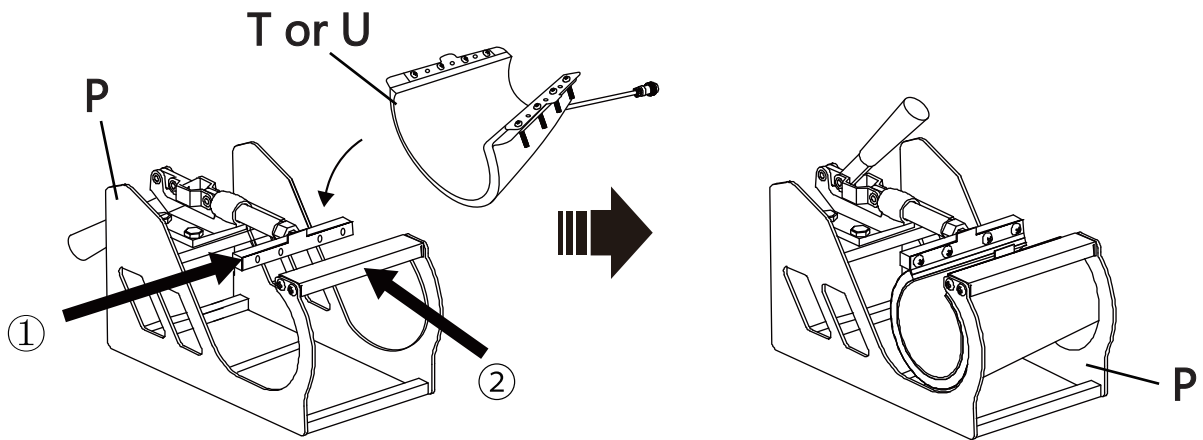

Install parts T or U to P.  
(Tighten the screws on both sides.  
Tighten the side screws of ① first,  
and then tighten ② side screws.)

Put mugs into Part T

2

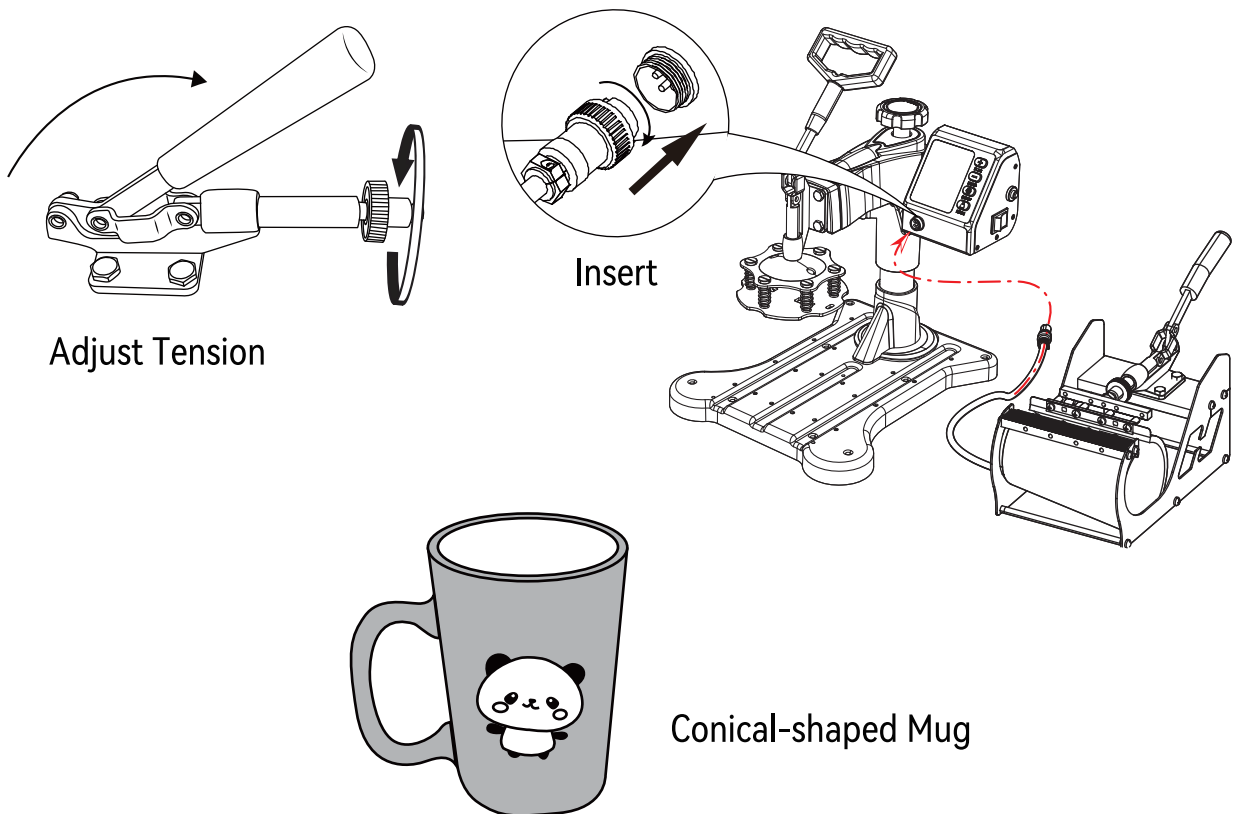

Adjust Tension

Insert

Conical-shaped Mug

# Assembly and Uses of Plate

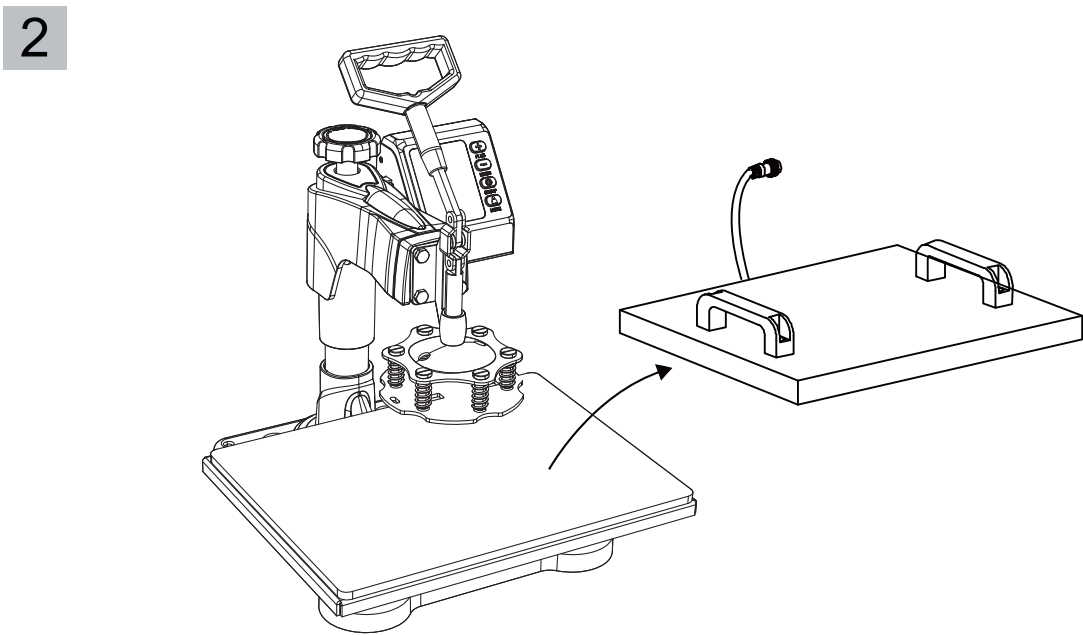
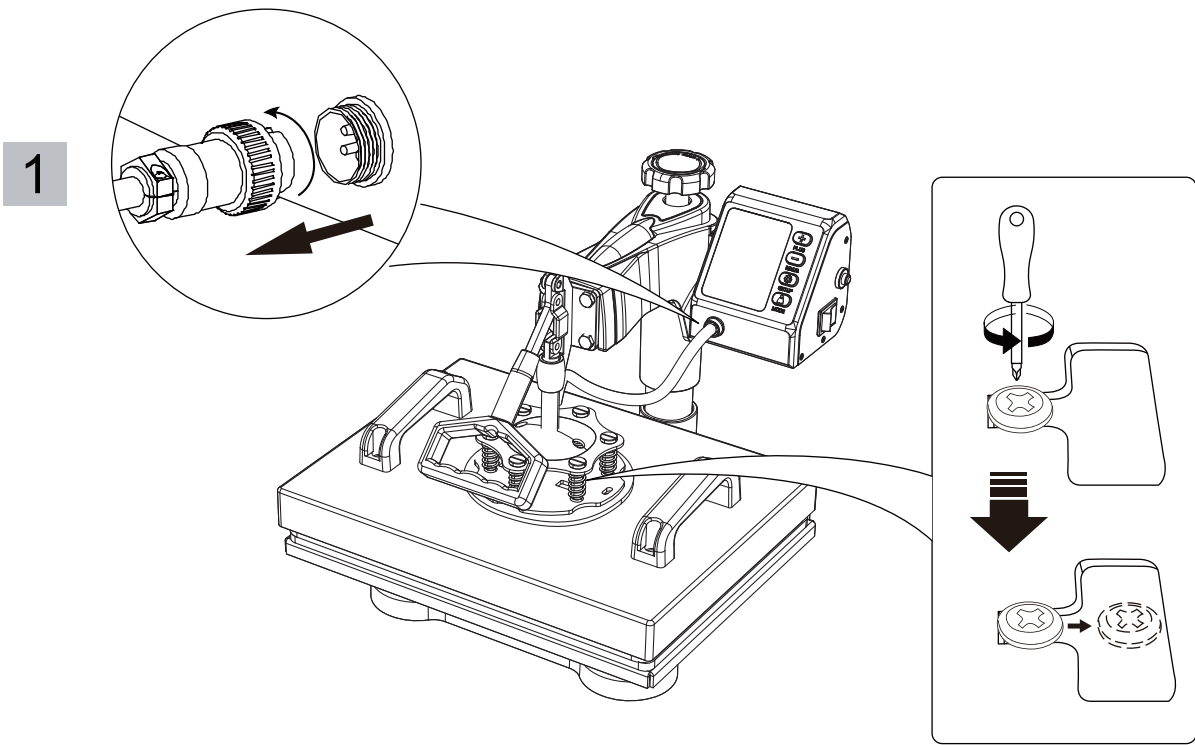

Take Out the Heating Platen

## Replace with a Plate Press

3

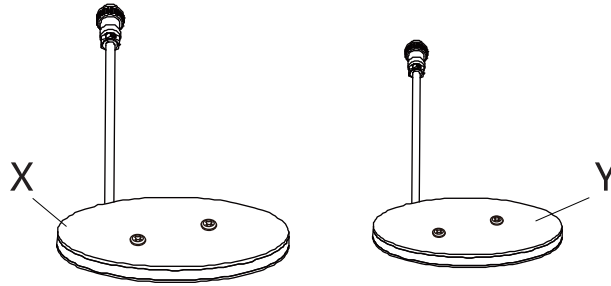

Choose the right size  
Plate Press (part X or Y).

4

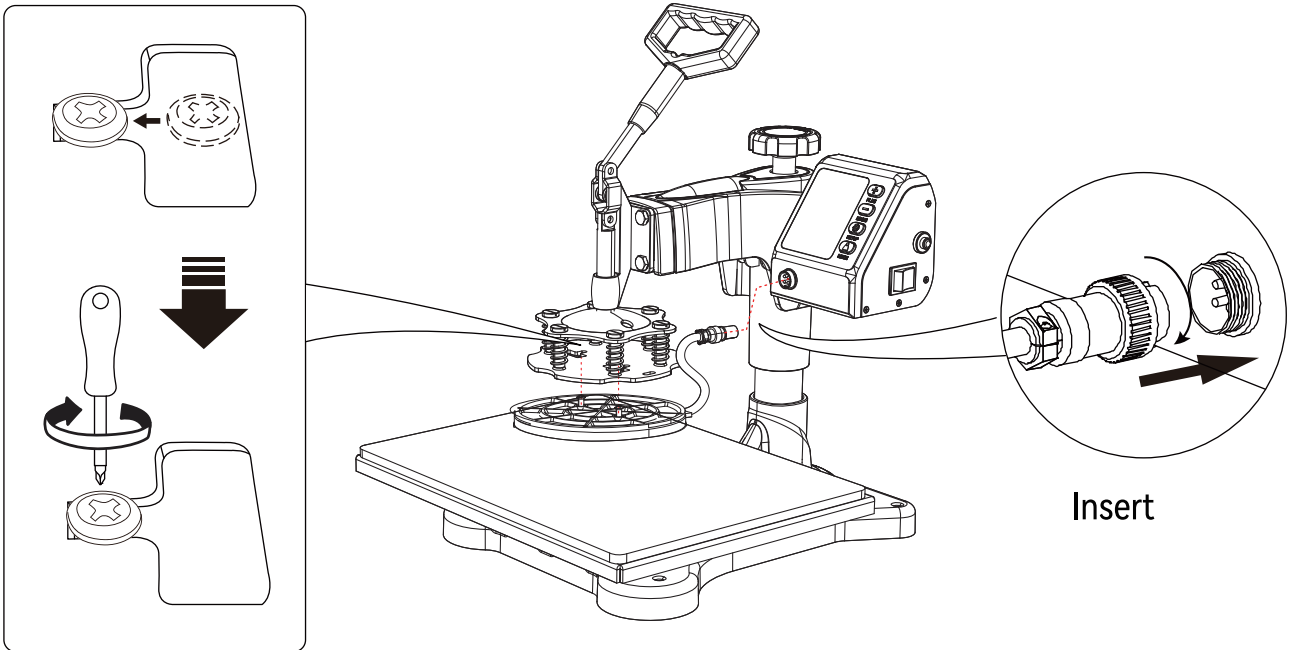

Finished Plate

## Method of Use

1. Adjust the pressure as needed (not too tight or too loose), plug in the power cord, and turn on the power switch.
2. At this point, the temperature will begin to rise. Set temperature and working time.
3. When the temperature rises to the transfer temperature, the buzzer will make a "drip" sound.
4. Press the button  , then spread the object ( T-shirt) flat on the press, pull down the handle to press the T-shirt.
5. Once the countdown ends, it will be accompanied by the sound of a long buzzer. (Note: Buzzer will sound for 5 seconds to inform you that the work is done).
6. Finish the work and take out the items.
7. Turn off the power switch.

## Treatment of Quality Defects in Transfer

1. Light Color or Faded Image: Insufficient Temperature / Incorrect Pressure / Insufficient Time.
2. Fuzzy Image: Pressing time is too long.
3. Part of the Pattern Blurred: The heat is not being distributed correctly through the heating plate, so the working time can be increased appropriately. It may also be the cause of uneven pressure distribution, which can be set on four board regulators. Please note that the four board regulators have been set up before they leave the factory and should not need to be adjusted normally.
4. Dim Pattern: Too much pressure or temperature.
5. Scarred Pattern: Transfer time is too long.
6. Different Pattern Colors: Incorrect pressure or poor quality of transfer paper.
7. Scorched Pattern: High temperature or poor ink.

## Warnings

- Please check voltage before use. Ensure that a reliable grounding protection connection is used.
- First, please turn off the machine, then disconnect the power supply, and finally replace the heating unit. If the equipment is still at a temperature, wear insulating gloves.
- Avoid long-term burning of heating parts during use. If you don't want to cut off the power supply, please place a heat transfer object ( scrap can be used repeatedly ), especially for preventing empty burning. Be careful not to let the sharp parts of hot stamping objects damage the heating parts.
- During use, avoid unprotected contact with heating parts and springs when the fuselage may be damaged, which may cause burns.
- If you feel it is hard to press down the handle, please rotate the handwheel to lock screws to lessen spring pressure; otherwise, it will damage the strength of the machine.
- When lifting the head, please lock the head with the rotary locking screw and loosen the handle ( the rotary locking screw should not be too tight ). In addition, when you reach the machine's closing limit, you will feel resistance on the handwheel, indicating that it is at its lowest point.
- Don't let minors touch the machine without supervision, even when the heating press is not in use!
- Do not try to heat press products that are not intended for transfer, and avoid empty burning.
- If the supply cord is damaged, it must be replaced by a special cord or assembly available from the manufacturer or its service agent.
- This device complies with Part 15 of the FCC Rules. Operation is subject to the following two conditions: (1) This device may not cause harmful interference, and (2) this device must accept any interference received, including interference that may cause undesired operation.



## Dispose :

This product is subject to the provision of European Directive 2012/19/EC. The symbol showing a wheeled bin crossed through indicates that the product requires separate refuse collection in the European Union. This applies to the product and all accessories marked with this symbol. Products marked as such may not be discarded with normal domestic waste, but must be taken to a collection point for recycling electrical and electronic devices.

Importer: WAITCHX

Address: 250 bis boulevard Saint-Germain 75007 Paris

Importer: FREE MOOD LTD

Address: 2 Holywell Lane, London, England, EC2A 3ET

Manufacturer address: Fuyuan Energy, Shengda Street, Chenxi Industrial Zone, Yiwu City, Zhejiang Province, China.

EC REP: EUREP GmbH Unterlettenweg 1a, 85051 Ingolstadt, Germany

eurep@eurep-gmbh.com +49 841 8869 7744

UK REP: Acumen IBC Ltd Ground Floor, 94 Ock Street, Abingdon, OX14 5DH

info@ukacumen.com +44 1235 200526

**VEVOR<sup>®</sup>**

E-mail: [CustomerService@vevor.com](mailto:CustomerService@vevor.com)