

VEVOR[®]

TOUGH TOOLS, HALF PRICE

AC SERVICE STATION USER MANUAL

We continue to be committed to provide you tools with competitive price. "Save Half", "Half Price" or any other similar expressions used by us only represents an estimate of savings you might benefit from buying certain tools with us compared to the major top brands and does not necessarily mean to cover all categories of tools offered by us. You are kindly reminded to verify carefully when you are placing an order with us if you are actually saving half in comparison with the top major brands.

Model: X585



NEED HELP? CONTACT US!

Have product questions? Need technical support? Please feel free to contact us:

 CustomerService@vevor.com

This is the original instruction, please read all manual instructions carefully before operating. VEVOR reserves clear interpretation of our user manual. The appearance of the product shall be subject to the product you received. Please forgive us that we won't inform you again if there are any technology or software updates on our product.

1. Instructions:

1.1 Safety cautions

1) **WARNING** : Read all safety warnings, instructions, illustrations and specifications provided with this electric appliance. Failure to follow all instructions listed below may result in electric shock, fire and/or serious injury. Save all warnings and instructions for future reference.

2) **ALLOW ONLY QUALIFIED PERSONNEL TO OPERATE THE MACHINE.** Before operation, read and follow the instructions and warnings in this manual. The operator must have knowledges about air conditioning and refrigeration systems, refrigerants, and the dangers of pressurized components. If the operator cannot read this manual, operating instructions and safety precautions must be read and discussed in the operator's native language.

3) **USE THE MACHINE AS OUTLINED IN THIS MANUAL.** Using the machine in a manner for which it was not designed will compromise the machine and nullify the protections provided.

4) **AVOID BREATHING IN A/C REFRIGERANT OR LUBRICANT VAPOR OR MIST.** Exposure can irritate eyes, nose, and throat. To remove refrigerant from the A/C system, use only equipment certified for the type of refrigerant being removed. Use the unit in locations with mechanical ventilation that provides at least four times ventilation per hour. If accidental system discharge occurs, ventilate the work area before resuming service.

5) **TO REDUCE THE RISK OF FIRE**, do not use the machine in the vicinity of spilled or open containers of gasoline or other flammable substances. Do not use an extension cord. Do not use the machine in the vicinity of flames and hot surfaces. Refrigerant can decompose at high temperatures and free toxic substances to the environment that can be noxious to the user. Do not use the machine in environments containing explosive gases or vapors. Do not use this machine in ATEX classified zones or areas. Protect the machine from conditions that can cause electrical failure or other hazards relating to ambient interaction.

NEVER remove ground prong from plug end. **DISCONNECT POWER** before servicing or removing any panels and covers. Plug into a grounded three-prong GFCI protected receptacle only.

NEVER modify this equipment in any way or warranty will be voided.

All repairs must be done by an authorized technician.

6) DO NOT PRESSURE TEST OR LEAK TEST EQUIPMENT AND/OR VEHICLE AIR CONDITIONING SYSTEMS WITH COMPRESSED AIR.

Mixtures of air and R1234yf refrigerant can be combustible at elevated pressures. These mixtures are potentially dangerous and can result in fire or explosion causing personal injury and/or property damage.

7) NEVER START THE MACHINE IF IT WILL NOT BE USED IMMEDIATELY. Disconnect the electrical supply before a long period of inactivity or before internal maintenance is performed.
DO NOT MODIFY THE PRESSURE RELIEF VALVE OR CHANGE THE CONTROL SYSTEM SETTINGS. Using the machine in a manner for which it was not designed will compromise the machine and nullify the protections provided.

8) HOSES CAN CONTAIN LIQUID REFRIGERANT UNDER PRESSURE. Contact with refrigerant can cause personal injury, including blindness and frozen skin. Wear protective equipment, including goggles and gloves. Disconnect hoses using extreme caution. Ensure the phase is complete before disconnecting the machine to prevent the release of refrigeration to the atmosphere.









9) PRESSURIZED TANK CONTAINS LIQUID REFRIGERANT. Do not overfill the internal storage vessel (ISV). Overfilling can cause explosion resulting in personal injury or death. Do not recover refrigerants into nonrefillable containers; use only type-approved refillable containers that have pressure relief valves.

10) Please note that after FLUSHING HOSES, there may still be 2%-5% refrigerant remaining in the plumbing, which may cause the mixing of different refrigerants.

11) This appliance can be used by children aged from 8 years and above and persons with reduced physical, sensory or mental capabilities or lack of experience and knowledge if they have been given supervision or instruction concerning use of the appliance in a safe way and understand the hazards involved. Children shall not play with the appliance. Cleaning and user maintenance shall not be made by children without supervision.

12) Type X attachment: If the supply cord is damaged, it must be replaced by a special cord or assembly available from the manufacturer or its service agent.

1.2 Safety signs

	<p>Read carefully</p>		<p>Wear protection goggles</p>
	<p>Don't use it outside when it's raining</p>		<p>Grounding protection.</p>
	<p>Wear gloves.</p>		<p>Electrical shock hazard.</p>
	<p>This product is subject to the provision of European Directive 2012/ 19/EC. The symbol showing a wheeled bin crossed through indicates that the product requires separate refuse collection in the European Union. This applies to the product and all accessories marked with this symbol. Products marked as such may not be discarded with normal domestic waste, but must be taken to a collection point for recycling electrical and electronic devices.</p>		
	<p>This device complies with Part 15 of the FCC Rules. Operation is subject to the following two conditions:(1)This device may not cause harmful interference, and (2)this device must accept any interference received,including interference that may cause undesired operation.</p>		

1.3 Exemption clause

This device is a high-precision auto repair device, which can cause damage if used improperly. Damage caused by the following circumstances is not covered by the warranty:

- 1) Unauthorized unpacking and replacement of the components of the product;
- 2) Improper installation and maintenance, calibration and use;
- 3) Electrical damage due to poor grounding;
- 4) The input signal is beyond the tolerance range of the product specification; 5) The output load is beyond the tolerance range of the product specification; 6) Damage caused by such as lightning, flood or other disasters;
- 7) Other Reasons for Inappropriate Use

2. . Product details

2.1 Functions:

- 1) Compatible with R134a and R1234yf Refrigerant;
- 2) Recovery, vacuum, recharge and leak detection of R134a and 1234yf refrigerants are completely automatic ;
- 3) Compatible for electric car, gasoline vehicle and hybrid ;
- 4) Automatic internal system cleaning to avoid the mixing of different refrigerants and compressor oils;
- 5) Fully digital display and 7 inches touch screen with service prompt;
- 6) 5 electronic scales for the weight measurement of R134a Tank, R1234yf Tank, PAG oil, POE oil, used oil;
- 7) Benefit from the deep recovery program, recovery efficiency is up to 95%;
- 8) HP/LP/HP+LP charge mode is select able;
- 9) Up to 20000 vehicle A/C service data base, addible and editable;
- 10) Print-out of completed services information;
- 11) Search the service management and unit operation record;
New oils bottles with patent design prevent the oil from becoming contaminated by air and humidity;
- 12) Use high-sensitivity sensors to realize the leak detection of A/C systems and equipment; Intelligent reminder for filter and vacuum pump oil changing;

2.2 Parameter:

Refrigerant: R134a and R1234yf;

Power Supply: 220-240V~, 50/60Hz

Power Consumption: 1100W ;

Operating Temperature Range: -20C~+60C; Display:

7 inch touch screen;

Recovery efficiency: 95% above;

Scale accuracy: 10g(Refrigerant Tank); Recovery capacity: 3/8HP;

Vacuum capacity: 180L/min;

Refrigerant Tank Capacity: 15kg(For both 2)

Oil Bottles: 3*350ml , (Hermetically sealed, PAG/POE/UV/Drain oil) ;

Electronic Scales: 5 (134a Refrigerant Tank、1234yf Refrigerant Tank、

PAG/POE/Used oil);

Filter Capacity: 100kg;

Net Weight: 130kg

Dimension (mm): 620*740*1350mm

2.3 Appearance

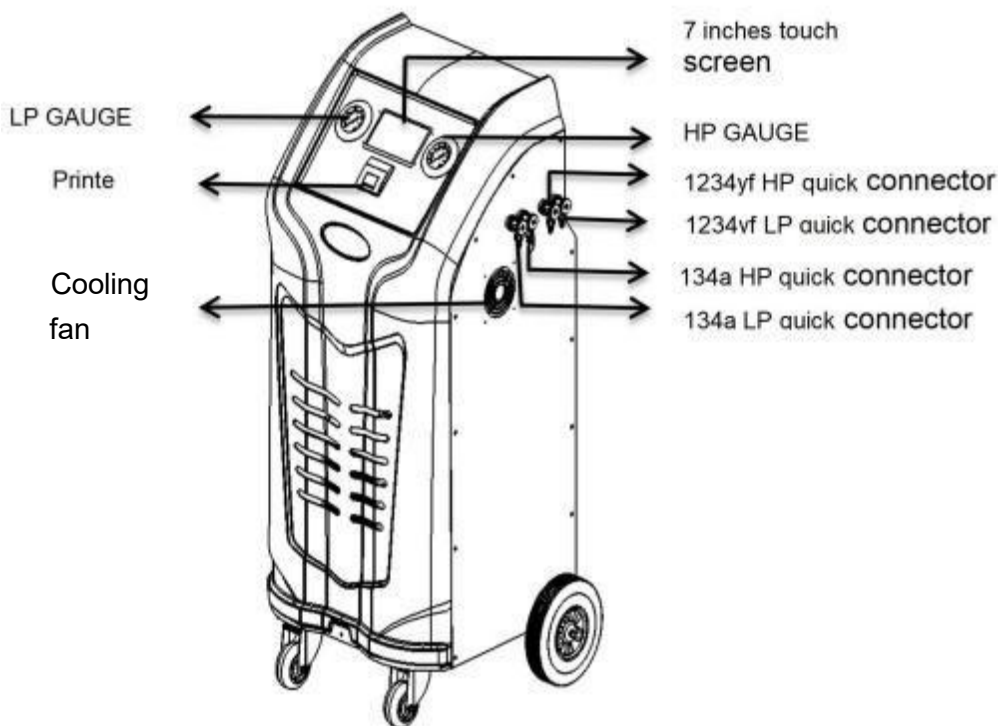

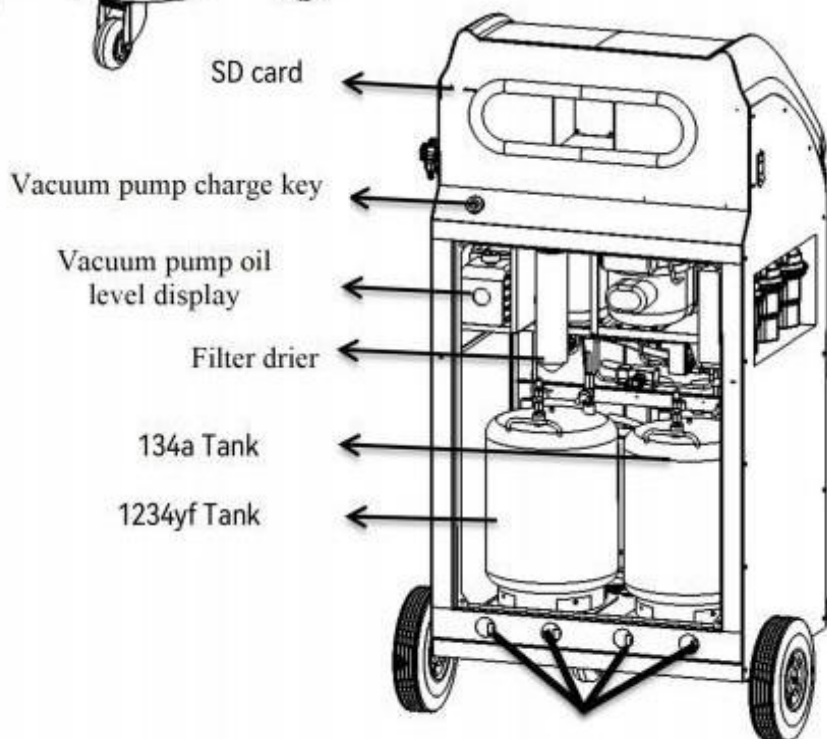
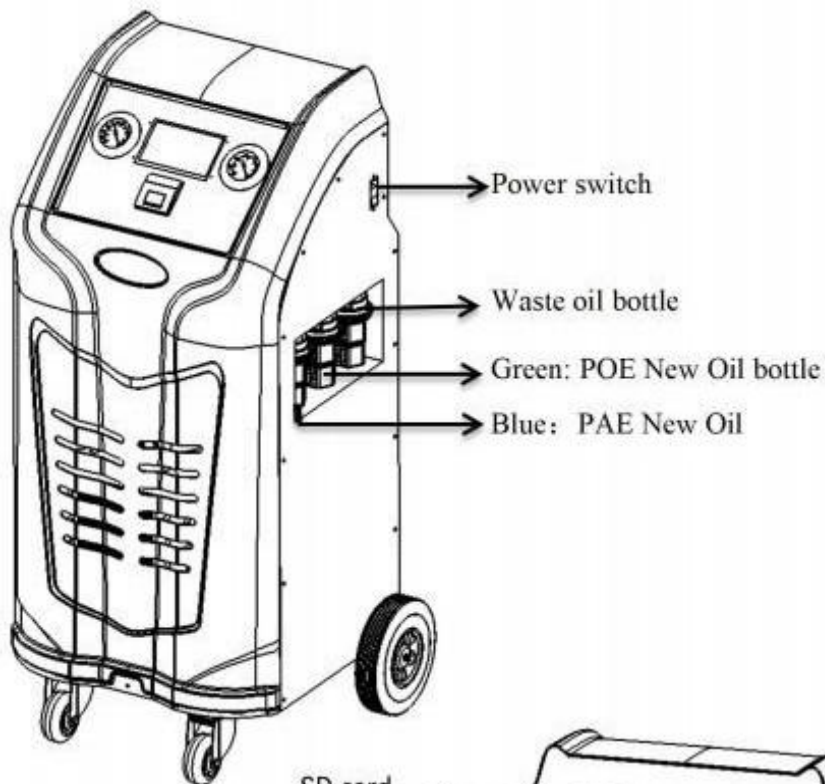

Note: The above picture is for reference only, the specific product appearance and color are subject to the actual product!

3. How to connect to the car:

1. Fix red coupler on red hose, and blue couplers on blue hose.
2. Fix red coupler to high side end, and blue coupler to low side end.

Guidance for basic operation prompts:

“Close the high side and low side couplers” :

Close the couplers anti-clockwise.

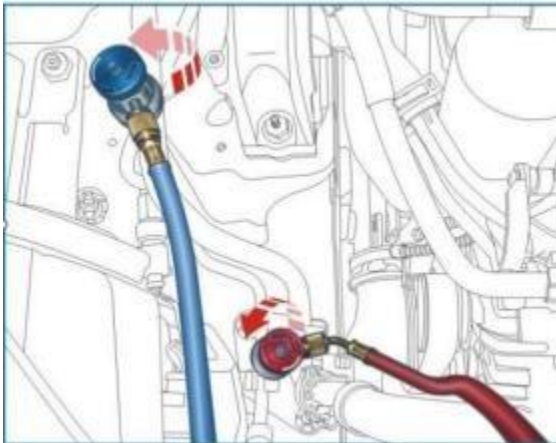

“Open the high side and low side couplers” :

Open the high side and low side couplers clockwise.

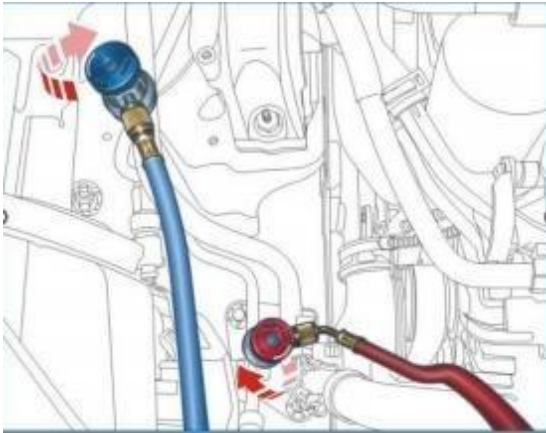

4. Initial Setup Instruction

Please follow the steps to install a new machine.

4.1 Electronic scale unlock

Unscrew the 4 screws on the rear door of the machine, find the tank scale under the R134a and R1234yf tank.

Use a hexagon tool to loosen the protection screw.

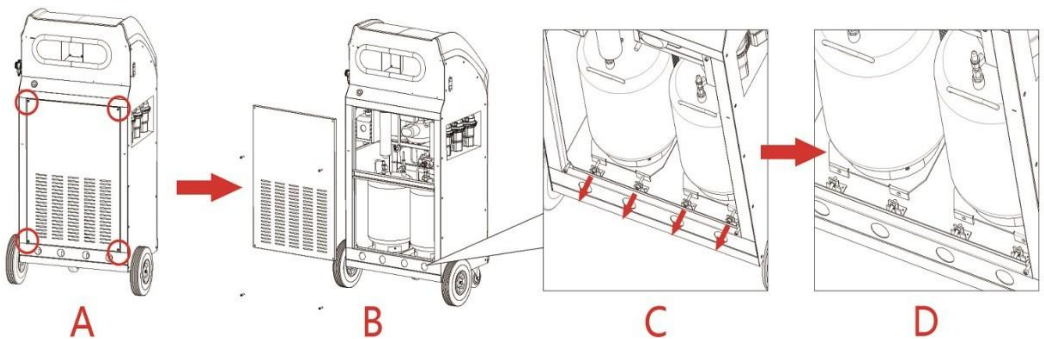

4.2 Tank Filling.

Before the first use, please refill 3-6 kgs/7-14 lbs refrigerant in the new machine.

- 1) Start the machine and select the required refrigerant and oil type.

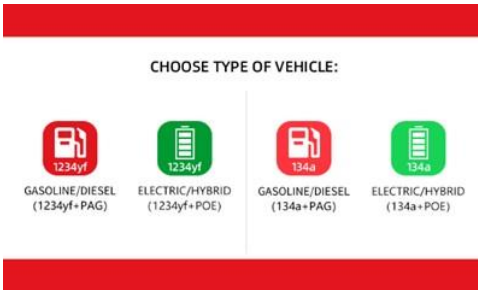

- 2)) Choose the menu "SETTING"

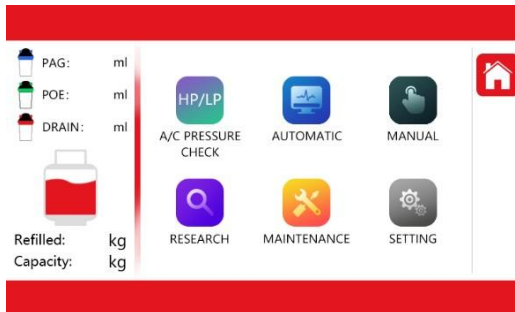

- 3)) Choose "Tank Filling"



4)) Set the amount for filling and press 



5)) Follow the instruction and press 

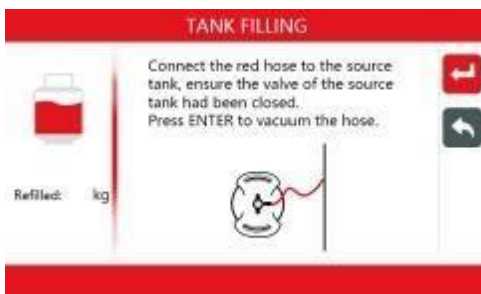

6) Doing vacuum, please wait.

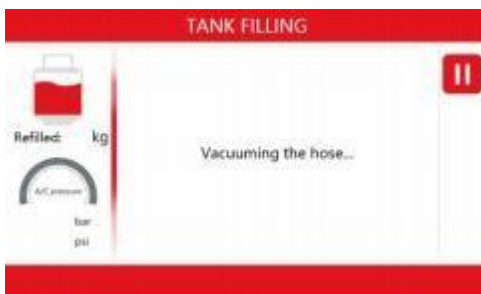

7) Follow the instruction to next step. Press 



8)) Vacuum completed, follow the instruction and press step.

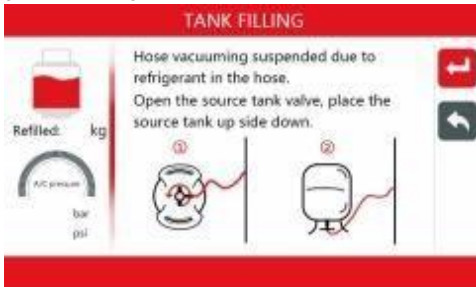
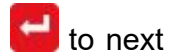

9) Refilling, please wait.



10) Refilling amount completed, close valve and press  to recover residue in hoses.



11) Tank filling completed. Press  back to MAIN MENU. Select another type of refrigerant for TANK FILLING.





12) After R134a and R1234yf TANK FILLING. Initial Setup completed. Back to MAIN MENU. You can use the machine now.

5. Basic Operations

5.1 Select the refrigerant type

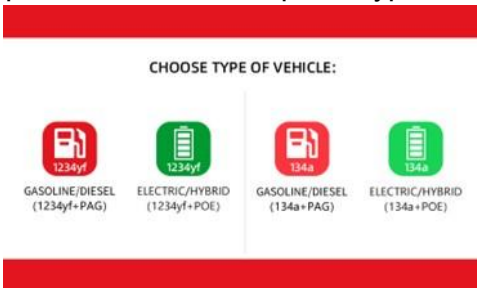
1) The unit is compatible with R134a and 1234yf refrigerants, please select the required type of refrigerant and oil.



- 2) If the refrigerant and oil type selected this time is the same as that selected in the previous operation, you can go to the next step directly.
- 3) If the selection is different from the last used refrigerant or oil, system will automatically prompt. Press  to enter automatic Flushing.

FLUSHING HOSES





Refilled: kg

Since the selected vehicle type is different from the last operation, Perform **FLUSHING HOSES** now to avoid different refrigerant and oil mixing.

Connect and open the HP and LP couplings as follows. Press ""







A/C pressure
bar
psi

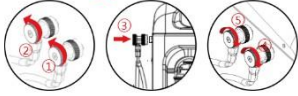

4)) Flushing hoses.

FLUSHING HOSES



Refilled: kg

FLUSHING HOSES...

AC Pressure: psi

5)) Hose cleaning, please wait.

FLUSHING HOSES

System cleaning suspended due to the HP hoses is not connected to the device or no refrigerant in the hose.

Please ensure the red & blue hoses are connected to the device, open the high & low side valves.





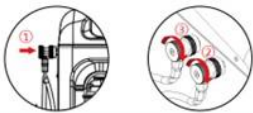

6)) Hose cleaning completed. Press  to next step. Replace the R134a/R1234yf HP hose and start to operate the unit.

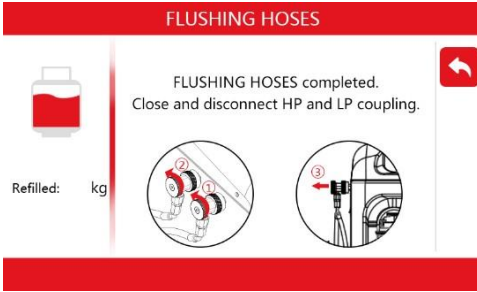

7)) If you need to re-select the type refrigerant, click  to back to the interface for selecting the refrigerant.



52 A/C pressure test

1)) Choose Main menu “A/C pressure check”



2) Follow the steps as instructed and press 

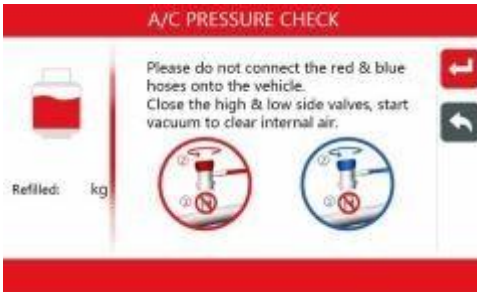

3) Cleaning the hoses.



4) Hose cleaning completed.

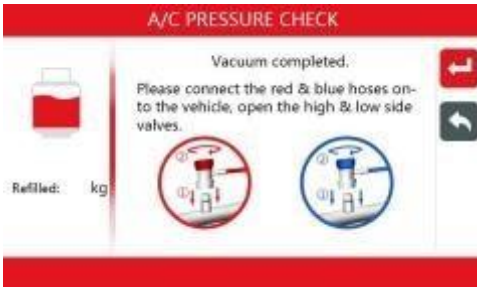

5) Choose the process you want to operate.



6)) Automatic: please refer to the prompts. 7) Manual: Please refer to the prompts.

8) Recovery residue: follow the steps as instructed and press  to next step.

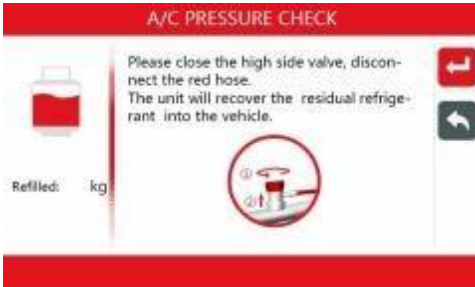

9)) Recovering residue, please wait.



10) Follow the instructions, then press 



11) Recovering, please wait.

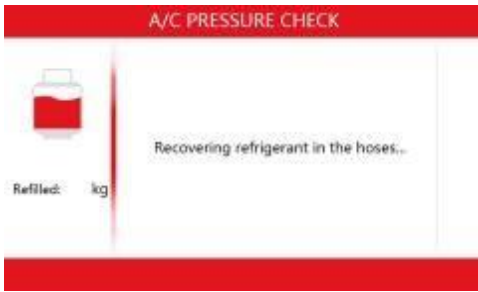

12) AC pressure check completed. Press  to exit.

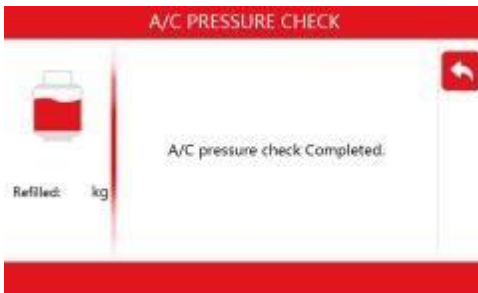

5.3 Full automatic operation:

1) Choose “Automatic”



2)) Choose whether to recovery the refrigerant as required, and press  to next step.



3)) Please set the parameter for vacuum or choose defaulted parameter, then press enter.



4) Set the parameter for charge. Click  to next step.

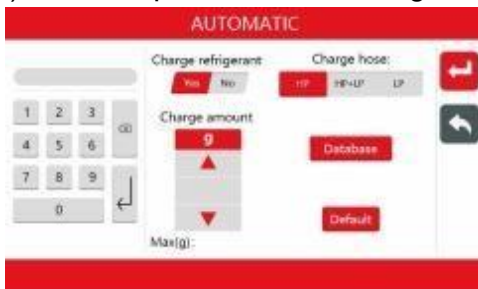



5)) Choose whether to add compressor oil or not, and select the type of compressor oil. Choose whether new oil = drained oil, or set the desired inject amount, click  to next step.



6) Ensure the value being correct and then press  . Otherwise, you can reset it.



7)) Follow the prompted instructions to operate.

8) Full automatic operation completed. Choose “ print” or not. Press  to print. Or press  to exit to main menu.

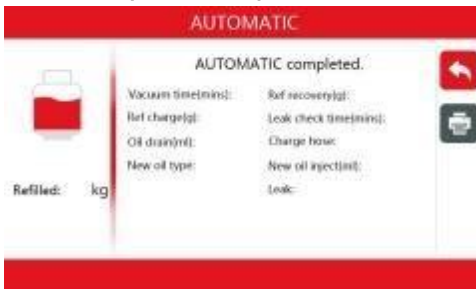

5.4 Manual operation

Choose menu of “A/C pressure check” to next.



Choose the process you want to operate



5.4.1 Recovery

1) Choose the mode of recovery, press  to next.



2) Follow the instructions and press  to next step.



3) Doing vacuum, please wait.



5) Vacuum completed. Follow the instructions and press  to next step.



5) Doing recovery, please wait.

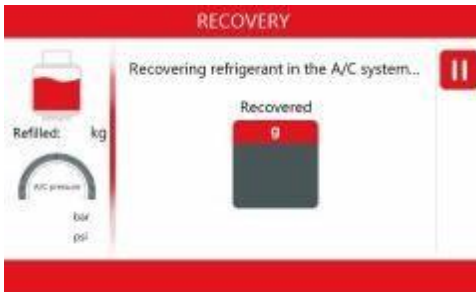

6) If you use the mode of deep recovery, it takes more time. Please be patient.



7)) Recovery completed. Please wait until oil drained.



8)) Recovery completed. Check the recovery amount and oil drain amount. Touch  to print or exit.

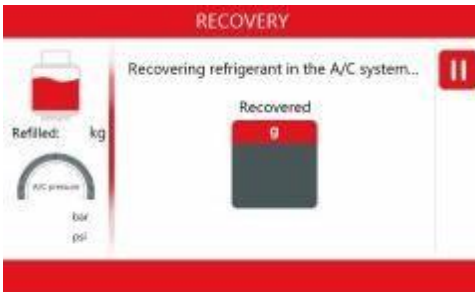

5.4.2. Vacuum

1) Set the parameter and press “enter” to confirm. Or use the default setting. Then press 



2) Follow the instruction to operate and press  to next step.



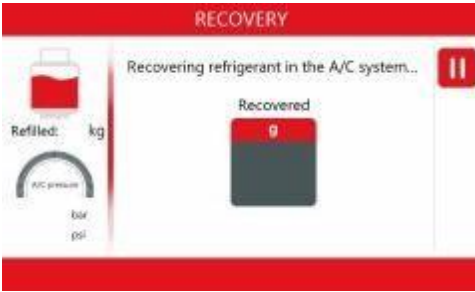

3) Vacuum in process, wait.



4) Leak testing if you have chosen that function.



5)) Vacuum completed. Double check all the parameters. press  to print, or press  back to Main menu.

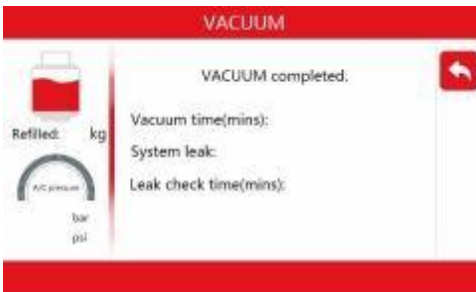

5.4.3 Charge

1)) Choose charge and set the parameters, or use default

parameters. Then press  to next step.

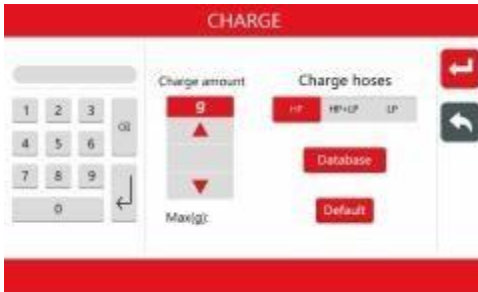

2)) Choose yes or no for oil injection and also oil type, set oil amount. Press  to next step.



3) Double check the parameter to confirm or press  to reset it.



4) Oil injection in process, please wait.

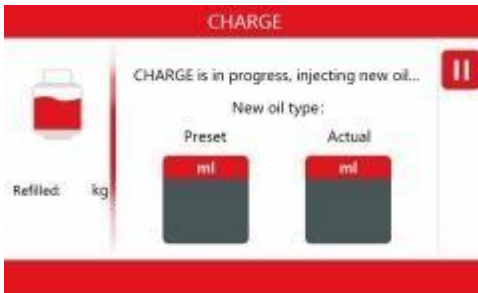

5) Charging refrigerant, please wait.

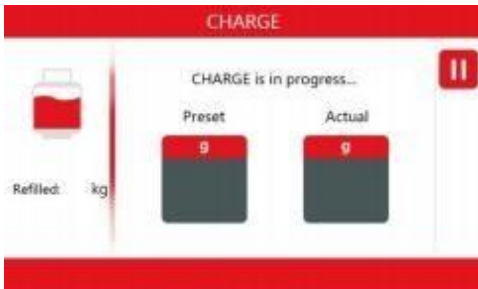

6) Follow the instruction to operate, then press  to next step.

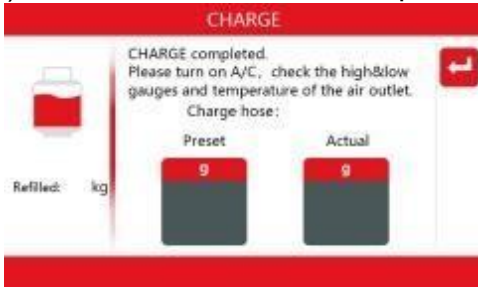

7) Follow the instruction to operate, then press  to next step.

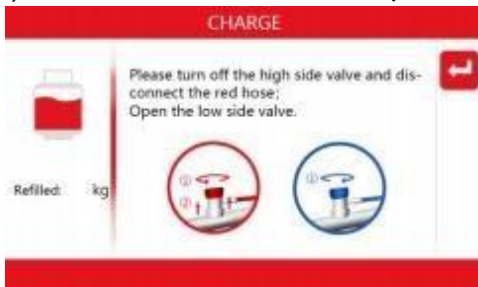

8) Balance the pressure, please wait.



9) Follow the instruction to operate and then press  to next step.

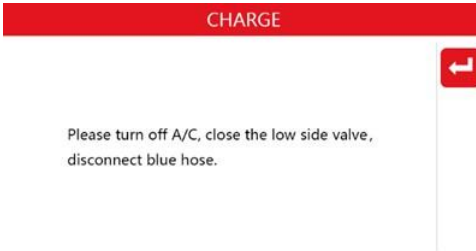

10) Make sure the low side valve closed, blue hose disconnected..

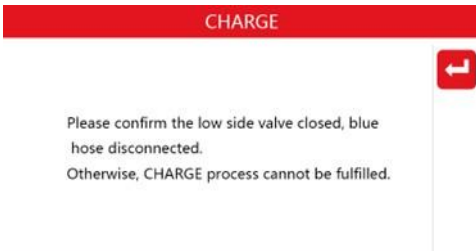

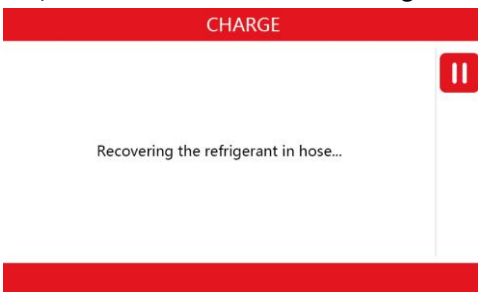

11) Recover the residue refrigerant from hoses.



12) Oil draining.

Draining oil in the hose...

13) Charge completed. Double check all the parameter. Press  to Print it or press  to exit.



6. Database:

Choose "Research"



Choose database.



Choose the country of the car model



Check all the information.



Insert SD Card to update database. This is only for manufacturer's use. The users don't need to operate.



The service report is available.



Maintenance information available.

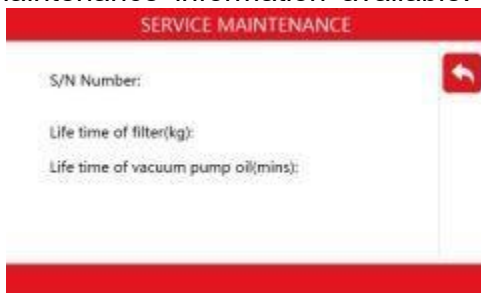

7. Maintenance:

Choose "Maintenance" in main menu



Choose the desired function.



7.1 1 Replace filter drier

1) Check the rest lifetime of filter. If need to replace, then press “yes”



2) Recover the refrigerant from filter.



3) Recovery completed. Follow the message and press step.

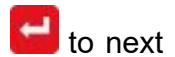

4 Follow the message and press





5) Leak checking. Please wait.



6) Filter drier replacement completed. Press  to exit.



72 Change pump oil

1) Check the rest pump oil lifetime. If necessary, choose 

CHANGE FILTER

Eusure the filter had been replaced correctly.

Press ENTER with vacuum and check for leaks.



2) Warm up the pump oil.

CHANGE VACUUM PUMP OIL

Running the vacuum pump to warm up the oil..

Warm up countdown(sec):

3)) Warm up completed. Follow the instruction to next step, press to next step.

CHANGE VACUUM PUMP OIL

The vacuum pump oil warm up completed.

Follow the prompts to replace the vacuum pump oil.

- 1.Place a disposal container under the unit, unscrew the drain cap to release the used oil. Close the drain cap after draining.
- 2.Add new oil until it reaches the centerline position of visual window.

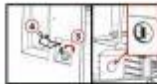
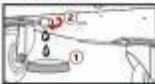

4)) Oil replacement completed.

CHANGE VACUUM PUMP OIL

CHANGE VACUUM PUMP OIL completed.

Remaining oil life(min):



7.2 Scale calibration

1)) Please input the password.



2)) Choose the desired calibration method and scale.

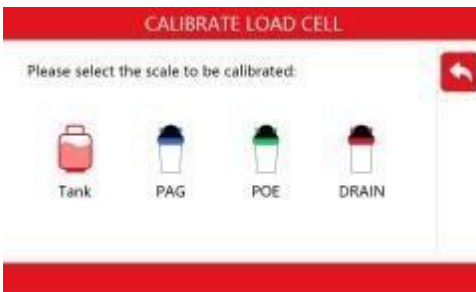
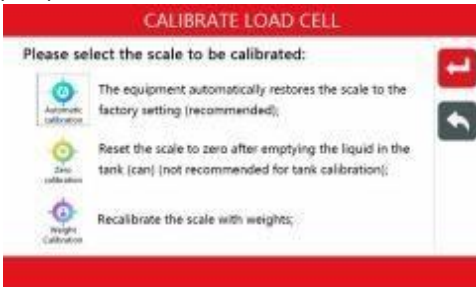

a) Automatic calibration (recommended)

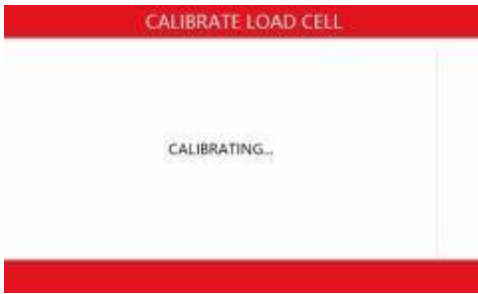

a- 1) Calibration completed. Please double check all the parameters.

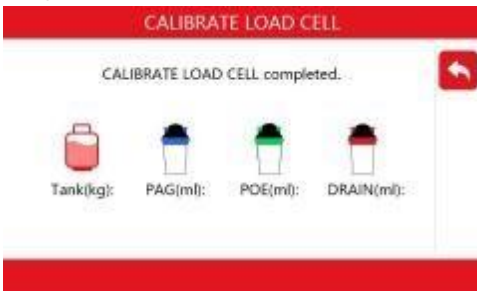

b) Zero calibration

b- 1) Follow the message and press 



b-2) Ensure the bottle is empty and press "Reset"

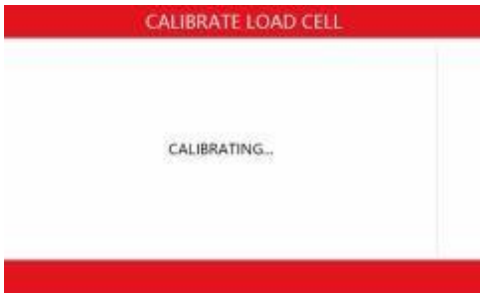

b-3) Reset it to zero, please press “Yes”



b-4) Please wait.

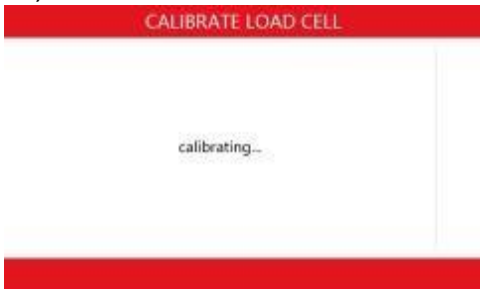

b-5) Calibration completed.

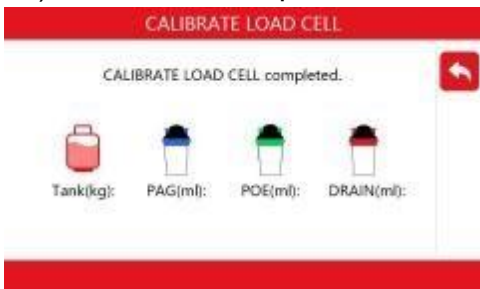

C) Calibrate the weights. Prepare the weights and enter its correct weight. Press  to next step.



C- 1) Follow the instruction to operate. Press  to next step.

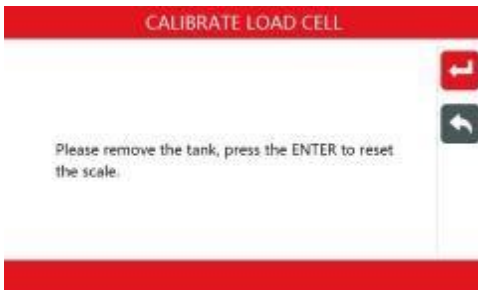

C-2) Follow the instructions to operate. Press  To next step.



C-3) Doing calibration, please wait.

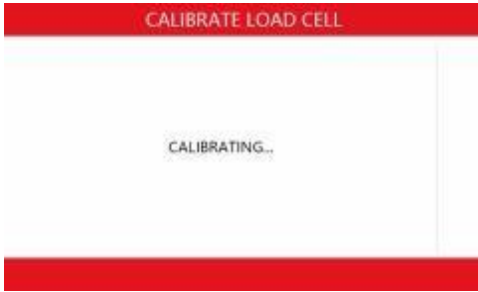

C-4) Calibration completed. Take out the weight.

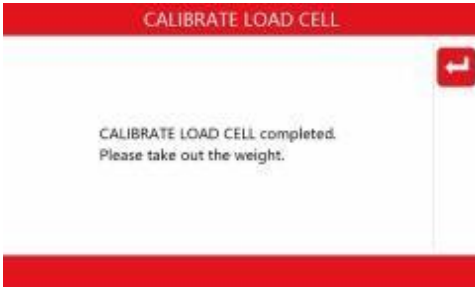

7.3 Leak test

1) Follow the instructions to operate. Press  To next step.

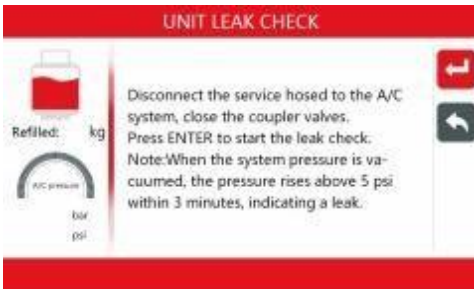

2) Leak testing, please wait.

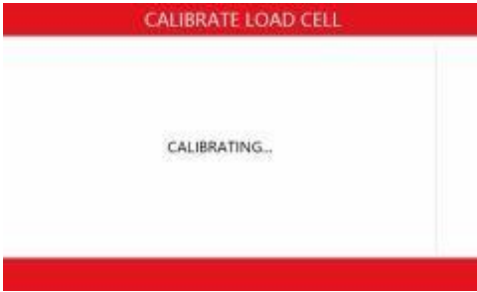

3) If any leak, please check manually.





4) If no leak, test completed.

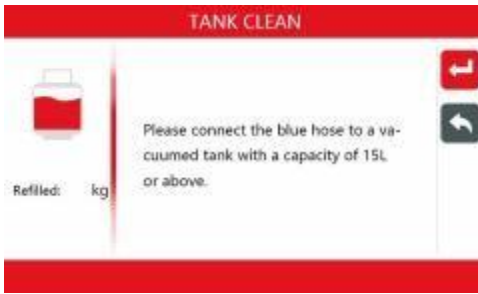

7.5 Clean tank

1)) Please follow the instructions to operate. Press  to next step. To next step.



2)) Set the weight needs to be cleanup. Press  to next step.



3)) Clean in process. Please wait.



4)) Tank cleanup completed.



7.6 Manual purge

Press  to release non-condensable gas.

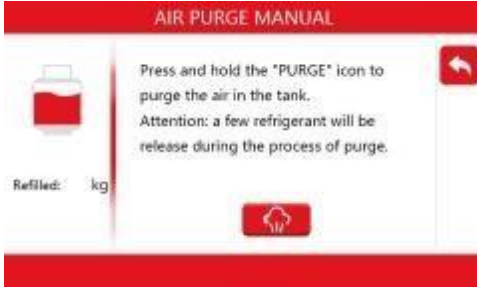

8. Setting

Choose “Maintenance” from Main menu.



Choose the desired functions.



- 1) Refill the cylinder, please refer to the installation chapter.
- 2) Lock setting. Please input the password to unlock it before

operation. Normally we don't suggest to lock the machine.



2-1) Input the management password, press  to continue.



2-2) Set the using times for locking, press  will enable the setting.



2-3) Block setting successfully.



9 Trouble Shooting

Display	Cause	Solution
1. RECOVERY FAILED	1. High tank pressure: full tank or poor refrigerant quality	Enter "Maintenance" - Manual Air purge
	2. Aging or damaged compressor	Change
	3. Relay fault	Change
	4. Solenoid valve leakage	Remove dirt or replace with a new solenoid valve
	5. The main board is faulty, recovery failed, but commands such as vacuum and charge can be performed.	Repair
	6. Poor wiring	Check wiring
	7. One-way valve or recovery solenoid valve blocked	Remove dirt or replace with new valve
2. Touch screen FAILED	1. Click the touch screen, no key sound	Replace the touchscreen
	2. Smashed by an object	Replace the touchscreen
	3. The screen does not display as a black screen, it may be a problem with the power supply of the motherboard	Repair the Main board and Check the Screen
	4. There is a key tone interface but no action	Repair the Main board
3. The electronic scale is not accurate	1. Incorrect operation to zero the recovered refrigerant	Enter "maintenance" - "load cell calibration" - "automatic calibration"
	2. The chassis screws are	Re-tighten tightening screws

	loose, fix the stability sensor screws, and the liquid storage tank fixing screws are loose	
	3 . Transportation or loose fixing screws make the wall of the liquid storage tank contact other parts of the equipment	Tighten the fixing screws of the weight after adjustment,
	4 . If you disassemble and repair without permission, you should pay attention to the arrow direction of the electronic scale is downward.	If it is installed in reverse, it needs to be adjusted and corrected
	5 . Damaged load cell	Change
	6 Damaged main board	Repair
4.Charge FAILED	1.The refrigerant in the internal tank is less than 1 kg	Recovery more than 1 KG of refrigerant to the tank
	2.Fill Mini can refrigerant to the tank .	Some technicians fill mini can of refrigerant (refrigerant with a weight of less than 1KG) to the internal tank .This approach is wrong. Internal Tank should be filled with a standard source tank ((usually weight 13.6KG)
	3. Filling valve is blocked or valve core is damaged	Clean or replace
	4 . Damaged main board	Repair
	5. Manually close the hand valve of the internal tank	Reopen
	6 . Incorrectly setting the filling amount to "zero"	Reset
5.VACUUM FAILED	1 . Vacuum pump failure	Change
	2 Relay failure	Change
	3. Damaged main board	Repair
	4 . Prompt that the pressure of the hose is too high and cannot be vacuum	Recovery or manually deflate the external hose to less than 0.5 KG/CM2
	5.Can not maintain pressure for leak detection	1 .Check A/C system for leaks 2.Whether the quick connector and hose of the refrigerant machine leak, or the leak of the vacuum pumping piping.

		3. Check PAG POE and UV solenoid valve for leakage
	6 . Filling valve leaks	Change
6 .Smoky vacuum pump	1. The vacuum pump oil is deteriorated	Change
	2 . Excessive vacuum pump oil, which accumulate vacuum pump oil in the vacuum pump for a long time when vacuuming the A/C system	Drain oil from vacuum pump to middle scale line
	3 The connector of the pipes may be loose and , which may cause smoke	Check and tighten the relevant connector.
	4. The vacuum time is too long, and the heat will cause the vacuum pump oil to evaporate.	Ignore
	5. Car A/C systems keep too much gas for a long time The vacuum pump fixing screw is loose	Ignore
7.Noisy vacuum pump	The vacuum pump fixing screw is loose	Re-fasten the screws



Pooledas Group Ltd
Unit 5 Albert Edward House, The
Pavilions Preston, United Kingdom

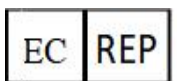

SHUNSHUN GmbH
Römeräcker 9 Z2021, 76351
Linkenheim-Hochstetten, Germany

Add: Baoshanqu Shuangchenglu 803long 11hao
1602A -1609shi Shanghai

Made In China

VEVOR[®]

TOUGH TOOLS, HALF PRICE

Support and E-Warranty Certificate

[https:// www.vevor.com/support](https://www.vevor.com/support)

Made in China