

CE

**THE OPERATING AND MAINTAINING
MANUAL ROPE
PULLING HOISTER**

A. Operating Principle

Wire Rope Pulling Hoister is operated in accordance with lever principle by the means of pulling the forward handle or the backward handle manually to make it move straight so as to finish such three performances as lifting, pulling and tensioning with less manual force to obtain the load of more tonnage.

It will make the fourlink clamping mechanic tension of the front jaw-blocks and the back ones inside the hoister move clamp---relax to pulling the forward handle or the backward handle to and forth. Then the pulling wire rope through the upper grip jaw and lower grip jaw of the tow pliers will always remain in the clamping state between the pliers and wire rope because of the pretension of the spring. Thanks to the function of the abrasive force of the interfaces and the pulling of the load, the fourlink clamping mechanism always inclines backward in the direction of the load so as to clamp the rope tightly. With the help of other connecting levers, the front jaw and the back jaw will clamp the loading wire rope alternately and slide through the upper jaw and the lower jaw of another pair so as to lift and lower the load.

The series of the hoisters have such unusual advantages as the alternate working sensitivity of pretension spring, less loss of the travel, high mechanic efficiency, less abrasion to the wire rope and so on. The pliers are reliable in working capacity, good in durable moving function and have good excellent processing and maintaining functions because the pliers are made in excellent steel and processed finely.

The forward handle has the safety protecting bolt. It will break when it is pulled too violently or overloaded. Can the safety bolt usually break automatically only when is over loads more than 1.25 times of its rated load but we guarantee that hoister can still be operated safely.

B. Usage

1. Reeve: (Fig.1) With the rope head downward and pressing the hoister, push the relaxed handle. When hearing the sound click, pliers mouth has been opened. Then you can reeve the wire rope from the back hole to the hoister. After the rope is out, the rope can be pulled to the length that you need and then push the relaxed handle back to clamp the rope tightly. When the forward handle or the backward handle pulled, the wire rope will automatically go into or come out of the hoister. Thus, the machine is in the normal state and it is teady to be used.

2. Anchor: Fixed axis is to be used to anchor the rope round the hoister. Connect the wire rope or the hanger with the fixed rope and tie the other end to the load, masts, etc. There is a relaxation proofing tunnel on the fixed axis. When the fixed axis is inserted the hoister case , is must be turned twice to the second tunnel till it is clamped tightly (Fig2). Then the operation can be done. Notice please. The end of the wire rope must be on the upper of the fixed axis so as to make the rope not block and move freely.

3. Operate: Hook the load on the hanger.

Do as following.

(1.)Lift (forward), tension: pull the forward handle. (Fig. 3: A, B)

(2.)Lower(backward): pull the backward handle.(Fig. 3: C,D)

(3.)Stop working: Whenever lifting or lowering the load, it will stop working to make the load stay in any position when the manual handle stops working.

(4.)Draw the rope out(Fig.1): Having finished the work, the pliers mouth will be opened as soon as the relaxing handle is pushed and then the wire rope can be drawn out of the end of the hoister. Clean the dirt on the rope, wind it into the steel cross in good order to be ready to use next time.

Finally, push back the relaxing handle in order to not let the pliers mouth open for long and to keep the pretension spring working well later.

C. Caution

1. Before operating the hoister, you must check all the tightened screw to see if any of them is loosened. If there is any, tighten it. And when pulling one of the handles, please make sure that whether the hoister works in good order and whether the other handles will move as it does. After the wire rope has been reeved, it can come out or go inside the hoister. The wire rope must be cleaned and is not twisted, cracked and part broken, otherwise the hoister will not work properly.

2. Strictly forbid in operation.

a. Never pull all the handles at the same time. Don't pull the relaxing handle after the load is being lifted.

b. Never pull the handle violently, otherwise the safety bolt will be damaged, Don't use any self-made safety bolt instead of that provided by our factory if this happens.

c. Never use any pulling lever whose length has been changed by any means. If any, the consequence should be answered by yourself.

d. Never stand in the load nor work on it(except working in a hanger frame).

When any worker works in a hanger frame, its total supporting weight should be reduced to one third rated power of the hoister and the worker in the hanger frame should take measure to protect himself in case some unhappy accident happens.

e. Never let the load move round when it is being lifted. If, it must be stopped.

f. Never use the wire rope chose by yourself instead of the old one, If it is done or any accident happens, the consequence should be answered by the users. When the diameter of the working part of the wire rope has been damaged by 10%, a new one provided by our factory should be replaced. Never reeve the rope from the head of the hoister(Fig.4) or the direction of the hook must not be used reversely. If it does so, Work can't be done or accident is easy to happen. While working, the anchored object should be strong enough so as to support the load to prevent any accident happening.

g. Keep the machine clean and don't let earth, mud or any other dirt pollute the machine. If polluted severely, it must be unassembled to be cleaned. When it is reassembled, never fix the parts by mistake and coat them with lime grease to keep it working properly.

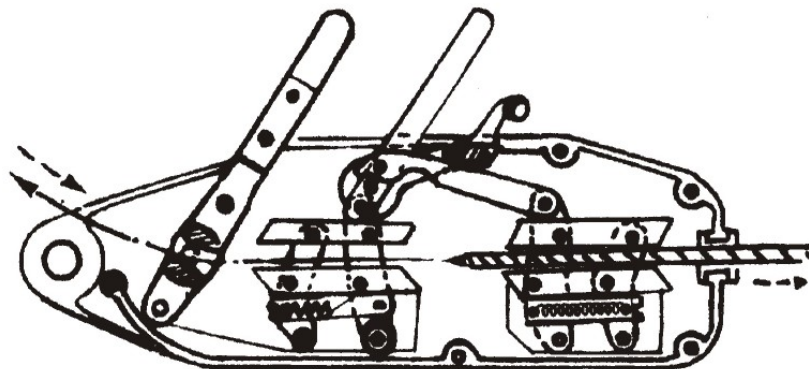

Fig1. Rope reeving and Rope receiving:

Push the relaxed handle to front direction by hand so as to insert its into the step formed on the top inner wall of the casing.

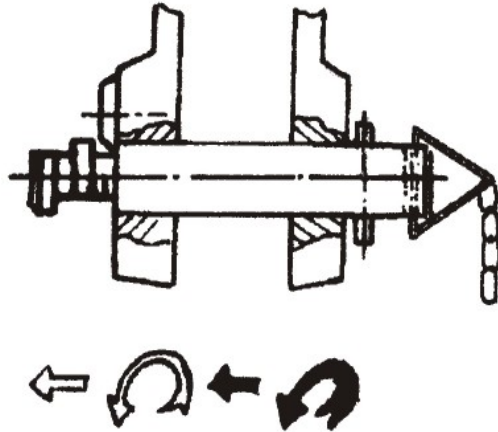

Fig2. Turn and push the fixed axis twice and let it enter the second tunnel

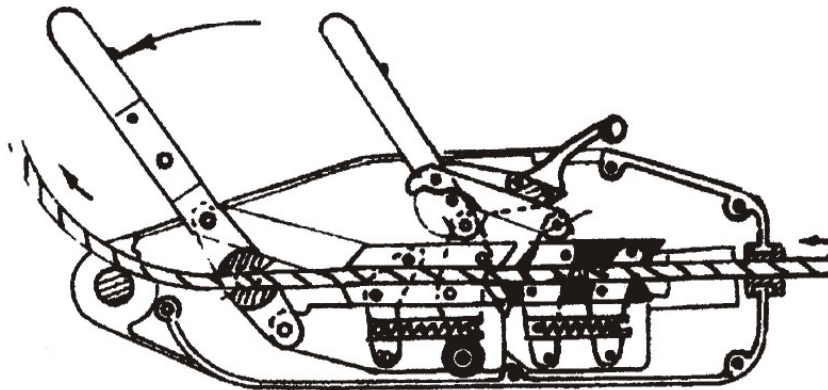

Fig3. A to lift a load (or pull a load forward):

Pull the handle forward, then the black clamping and the white relaxed.

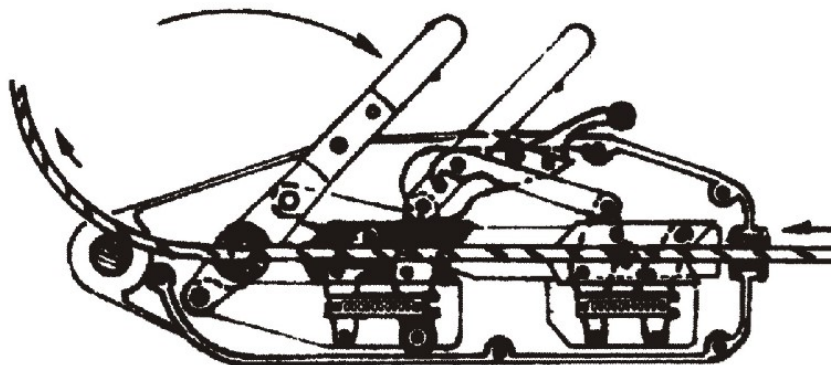

Fig3 B. To lift a load (or pull a load forward): pull the handle Backward, then the black clamping and the white relaxed.

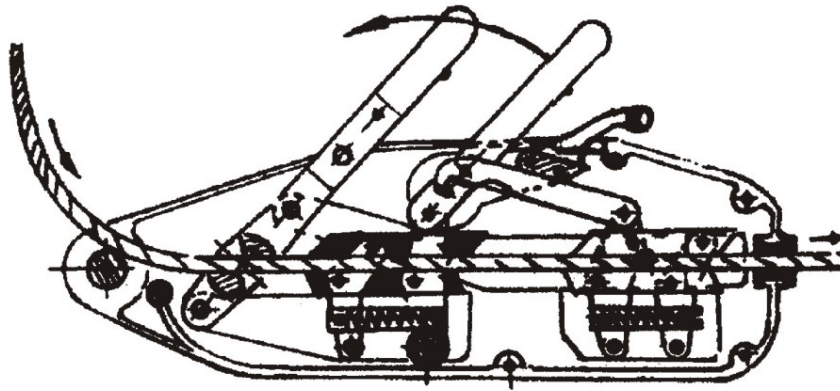

Fig3 C. To lower a load (or pull a load back ward):

Pull the handle forward, then the black clamping and the white relaxed.

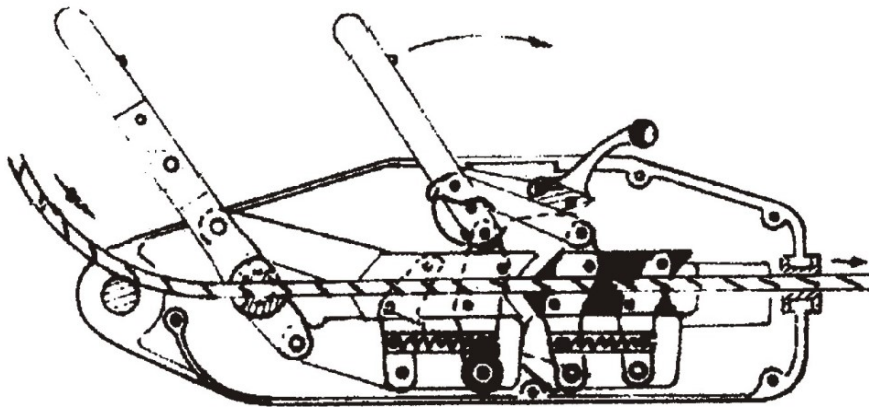
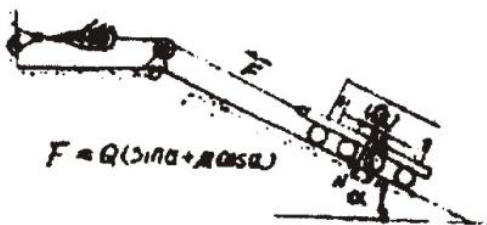
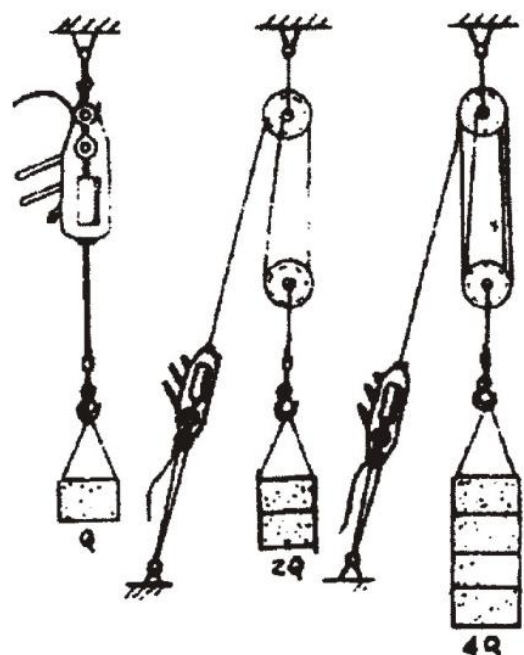

Fig3 D. To lower a load (or pull a load backward):

Pull the handle backward, then the black clamping and the white relaxed.



Unlinear pulling



Its capacity may be increased by using movable Pulley blocks

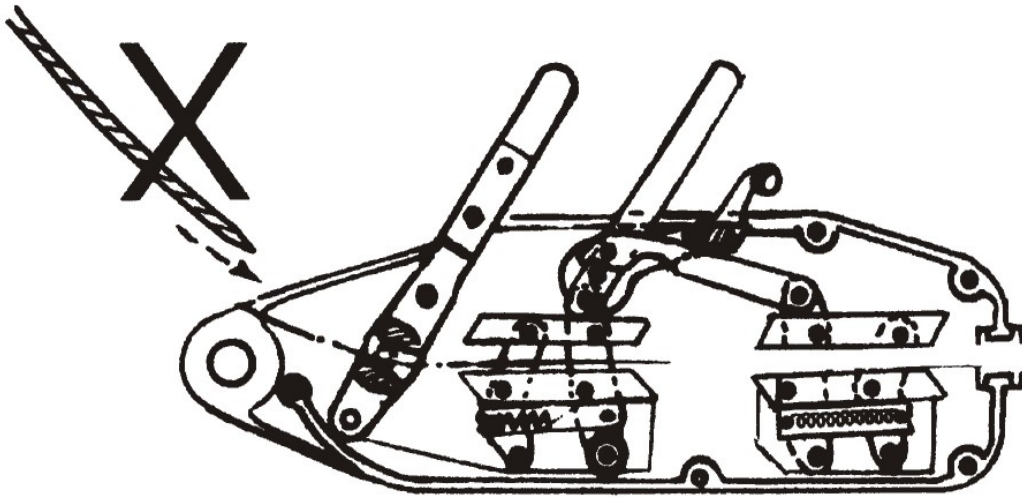
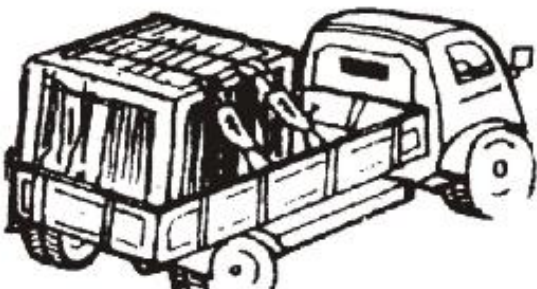
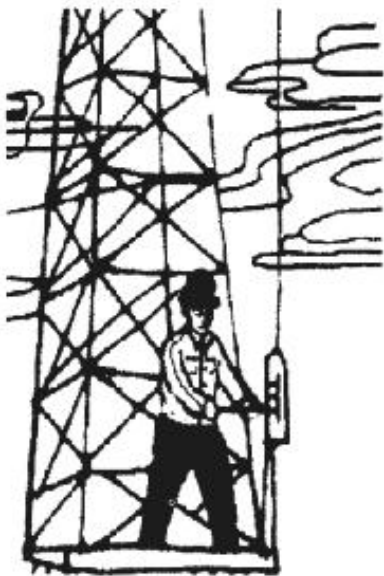
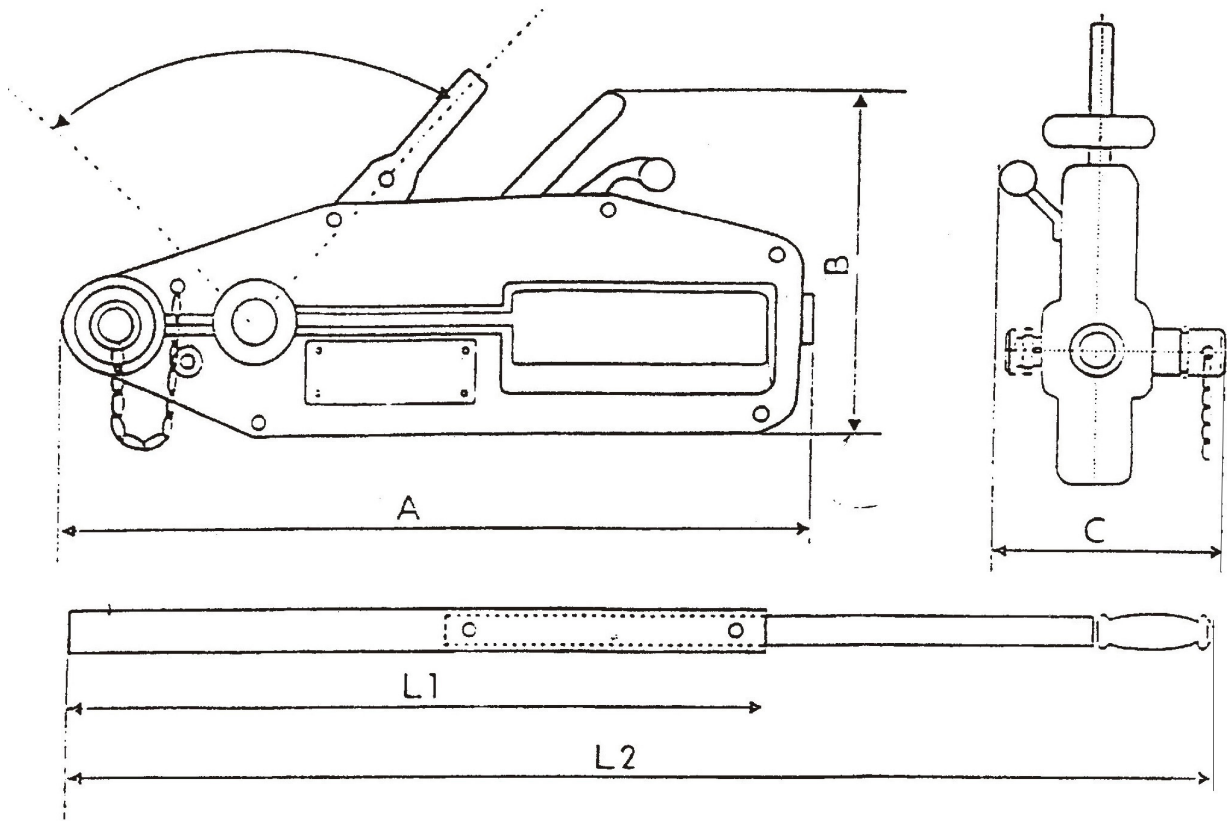

Fig4. Never use the wire rope chose by yourself instead of the old one. If it is done or any accident happens, the consequence should be answered by the users. When the diameter of the working part of the wire rope has been damaged by 10%, a new one provided by our factory should be replaced. Never reeve the rope from the head of the hoister or the direction of the hook must not be used reversely. If it does so, work can't be done or accident is easy to happen. While working, the anchored object should be strong enough so as to support the load to prevent any accident happening.

Scope of application





Wire Rope Pulling Hoist Specifications

Item \ Model	LJ-800	LJ-1600	LJ-3200	LJ-5400
Rated capacity (kg)	800	1600	3200	5400
Rated forward handpower (N)	341	400	438	550
Rated forward travel (mm) (Swing it front and backward)	≥52	≥55	≥28	≥25
Rope diameter (mm)	8.3	11	16	20
Wire rope safety factor load capacity	4	4	4	4
Safety factor & Static load capacity	4	4	4	4
Max travelling load (kg)	1200	2400	4800	6750
Net weight	6.4	12	23	58
Max overall size	A	426	545	660
	B	238	284	325
	C	64	97	116
L1 (mm)		692	692	692
L2 (mm)		1200	1200	1200
L3 (mm)	800			

Lj-3200

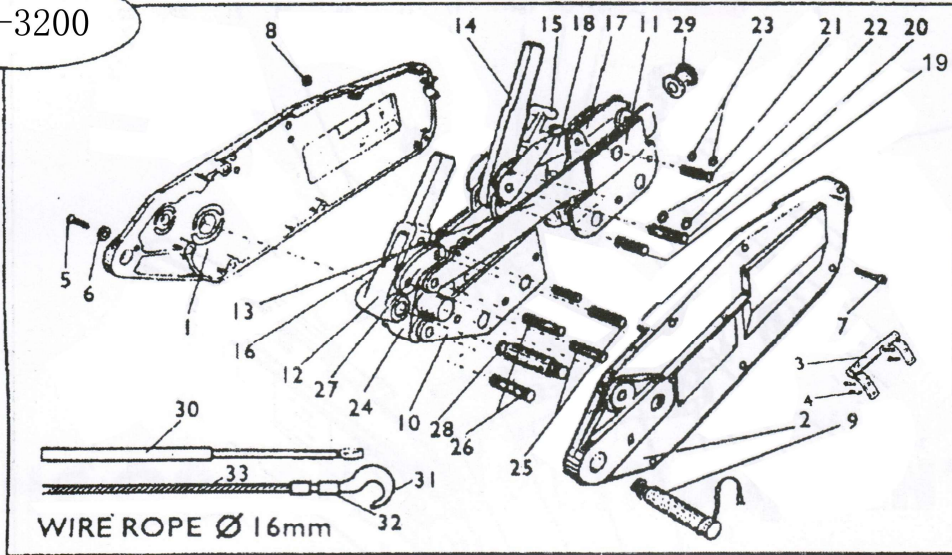

Parts Name

- 1.Left side plate
- 2.Right side plate
- 3.Handle(inner safety pin)
- 4.Rivet
- 5.Flat screw
- 6.Special retainer
- 7.Hex-Bolt
- 8.Hex-Nut
- 9.Fixed axle
- 10.Front Jaw Block
- 11.Back Jaw Block
- 12.Forward Handle assembly
- 13.Long Connecting Rod
- 14.Backward handle
- 15.Released handle
- 16.Safety pin
- 17.Upper grip jaw
- 18.Connecting rod
- 19.2nd pin
- 20.3rd pin
- 21.4th pin
- 22.Snap spring
- 23.Snap spring
- 24.Crank
- 25.5th pin
- 26.Crank axle
- 27.Connecting rod
- 28.Stay pin
- 29.Guide tube of Wire rop
- 30.Tube handle
- 31.Hanging Hook
- 32.Rivet Buckle
- 33.Wire Rope

LJ-1600

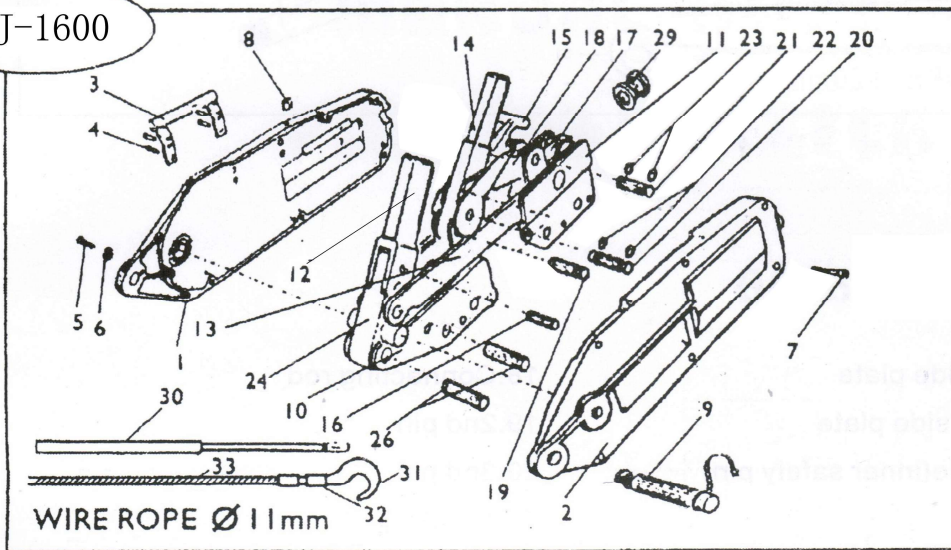

LJ-800

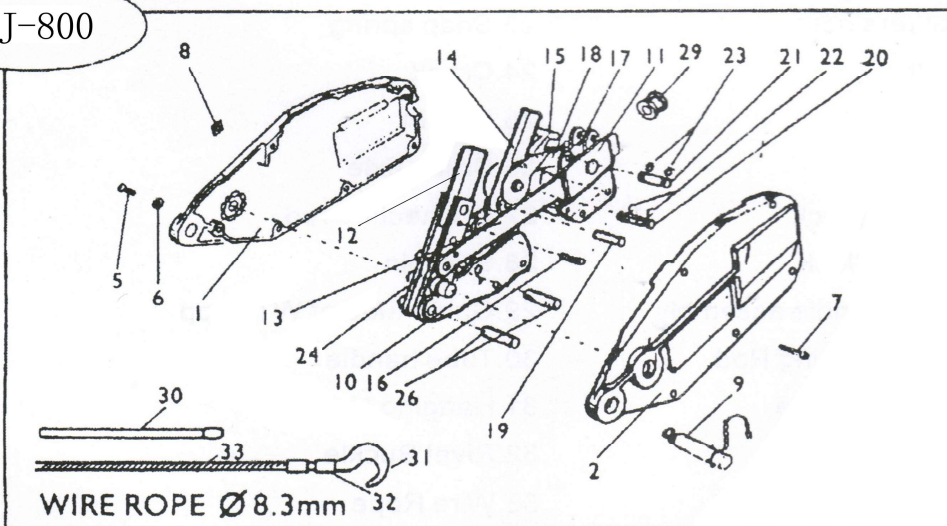

LJ-5400

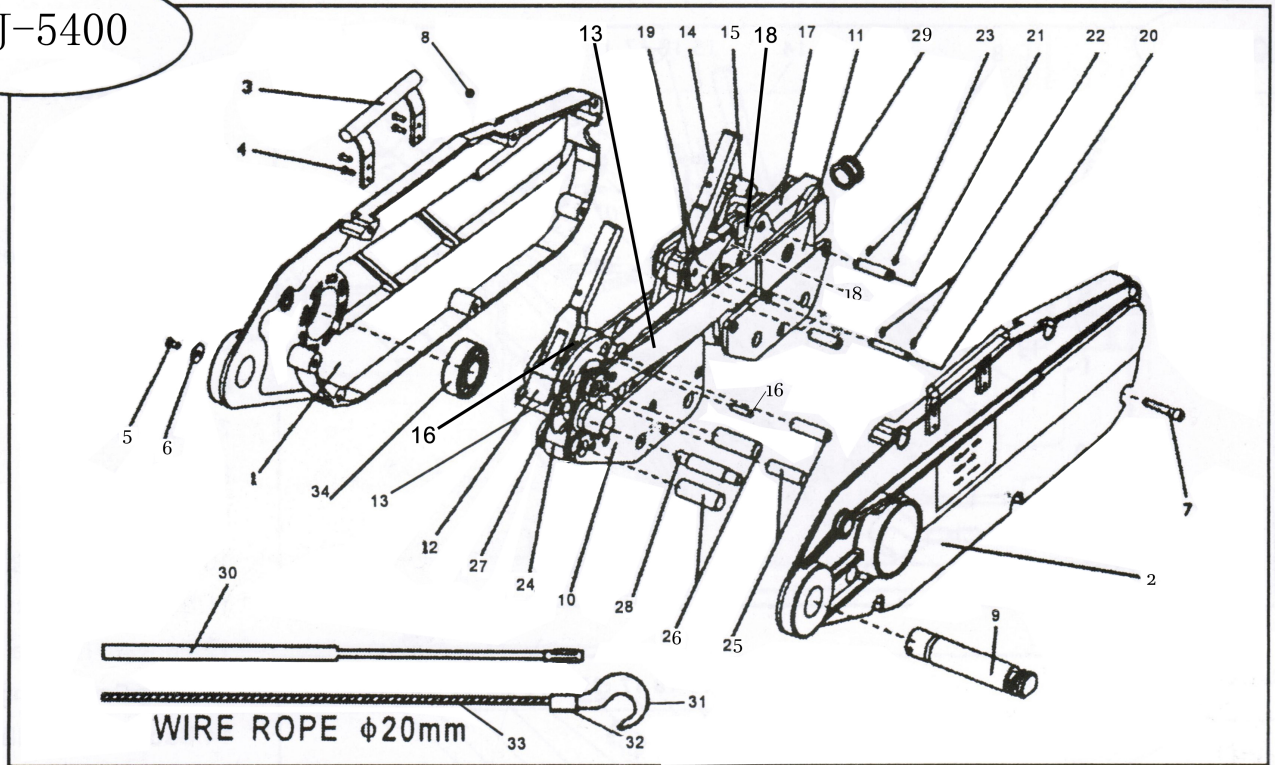

Parts Name

- | | |
|-----------------------------|----------------------------|
| 1. Left side plate | 18. Connecting rod |
| 2. Right side plate | 19. 2nd pin |
| 3. Handle(inner safety pin) | 20. 3rd pin |
| 4. Rivet | 21. 4th pin |
| 5. Flat screw | 22. Snap spring |
| 6. Special retainer | 23. Snap spring |
| 7. Hex-Bolt | 24. Crank |
| 8. Hex-Nut | 25. 5th pin |
| 9. Fixed axle | 26. Crank axle |
| 10. Front Jaw Block | 27. Connecting rod |
| 11. Back Jaw Block | 28. Stay pin |
| 12. Forward Handle assembly | 29. Guide tube of Wire rop |
| 13. Long Connecting Rod | 30. Tube handle |
| 14. Backward handle | 31. Hanging Hook |
| 15. Released handle | 32. Rivet Buckle |
| 16. Safety pin | 33. Wire Rope |
| 17. Upper grip jaw | 34. Bearing |