



Technical Support and E-Warranty Certificate [www.vevor.com/support](http://www.vevor.com/support)

# **TRANSMISSION JACK USER'S MANUAL**

**MODEL:**

We continue to be committed to provide you tools with competitive price.

"Save Half", "Half Price" or any other similar expressions used by us only represents an estimate of savings you might benefit from buying certain tools with us compared to the major top brands and does not necessarily mean to cover all categories of tools offered by us. You are kindly reminded to verify carefully when you are placing an order with us if you are actually saving half in comparison with the top major brands.

# VEVOR®

## TRANSMISSION JACK

SD0601



<Picture Only For Reference >

### NEED HELP? CONTACT US!

Have product questions? Need technical support? Please feel free to contact us:

 [CustomerService@vevor.com](mailto:CustomerService@vevor.com)

This is the original instruction, please read all manual instructions carefully before operating. VEVOR reserves a clear interpretation of our user manual. The appearance of the product shall be subject to the product you received. Please forgive us that we won't inform you again if there are any technology or software updates on our product.

**Read the instructions carefully before using the device**

# 1. Technical parameters

<b>Brand</b>	VEVOR
<b>Model</b>	
<b>Max Load(kg)</b>	600
<b>Product size ( mm)</b>	
<b>Product weight (kg)</b>	42

## 2. Safety precautions



### **WARNING:**

Read this manual before using this product. Failure to do so can result in serious injury. SAVE THIS MANUAL

#### **1) Position the Jack**

Position the jack to only lift on the areas of the vehicle as specified by the vehicle manufacturer.

#### **2) Always Use Jack Stands**

DO NOT USE woodblocks or any other non-approved lifting devices for a means of lifting with the jack and or load being raised. Failure to heed these warnings may cause injury or death.

#### **3) Do Not Overload Jack**

Do not overload this jack beyond its rated capacity. Overloading this jack beyond its rated capacity can cause damage to or failure of the jack.

#### **4) Always Use on Hard Level Surfaces**

#### **5) Chock and Block (Stabilize)**

- Apply parking brake in vehicle before operating jack.
- A chock is a wedge for steadying an object and holding it motionless, or for preventing the movement of a wheel

- Chock the wheel opposite the end being lifted.
- When you block a load, you secure and support a load that is being lifted. The block(s) or stabilizer(s) should have a weight capacity that is greater than the weight of the load which is being lifted.

#### **6) Center Load on Jack Saddle**

Off-center loads and loads lifted when the jack is not level can cause loss of load or damage to the jack.

- 7) Do not raise or lower the vehicle unless tools, materials and people are clear.
- 8) Always lower the jack slowly.



### **WARNING:**

#### **DO NOT USE THE JACK TO SUPPORT OR STABILIZE A LOAD.**

Using the jack to support or stabilize a load may result in unexpected movement and result in serious injury, being crushed and death. Always securely chock and block (stabilize) the load to be lifted. Never place any part of the body under a raised load without properly chocking and supporting the load.

\*Never use the jack on curved or tubular vehicle.

Bumpers, this will result in the vehicle slipping off the jack and falling, causing serious injury or death. Use a bumper lift for vehicles with curved bumpers or plastic bumpers.

\*Do not move or dolly vehicle while jack is in use.

### 3. Product structure diagram

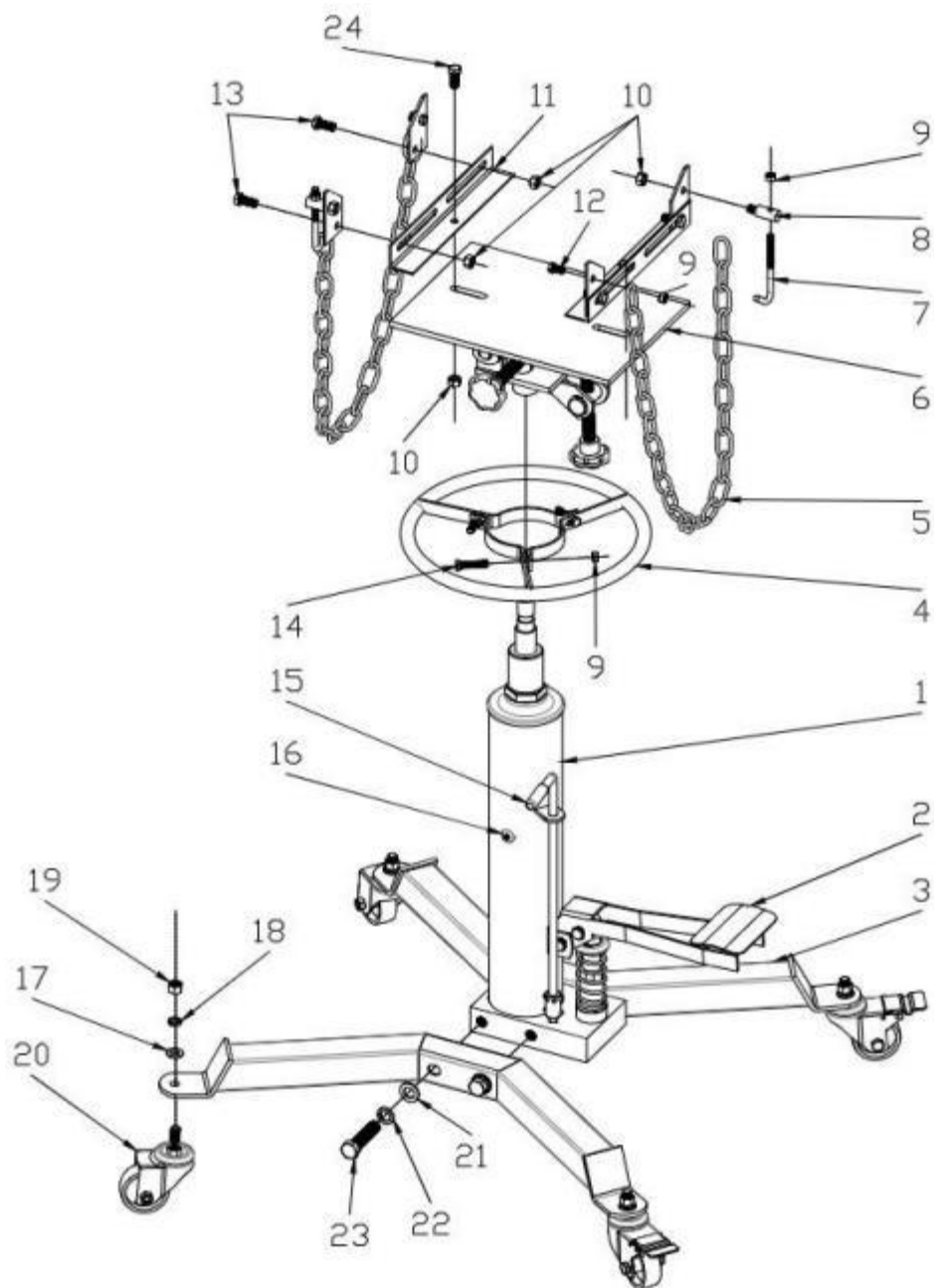

No.	Part name	Qty	No.	Part name	Qty
1	Cylinder	1	13	Screw M10*16	6
2	Foot Pump Pedal	1	14	Screw M8*40	3
3	Base	2	15	Release Handle	1
4	Handle	1	16	Oil Screw	1
5	Chain	2	17	Washer 12	4
6	Saddle	1	18	Spring Washer 12	4
7	Bent Bolt	2	19	Nut M12	4
8	Bolt Column	2	20	Caster Wheels	4
9	Nut M8	7	21	Spring Washer 16	4
10	Nut M10	8	22	Washer 16	4
11	Angle Iron	2	23	Screw M16*70	4
12	Screw M8*16	4	24	Screw M10*20	2

#### **4. Instructions of use**

Step 1: Install casters under the base (4 M12 nuts, 4 12 flat pads, 4 12 spring pads, a 19mm open wrench or 19mm socket wrench)

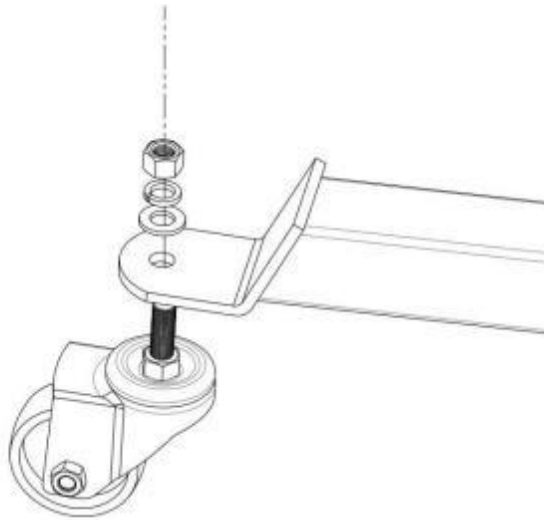

Step 2: Install the base on the side of the cylinder base (4 M16 \* 70 bolts, 4 16 spring pads, 4 16 flat pads, using a 24mm open wrench or 24mm socket wrench)

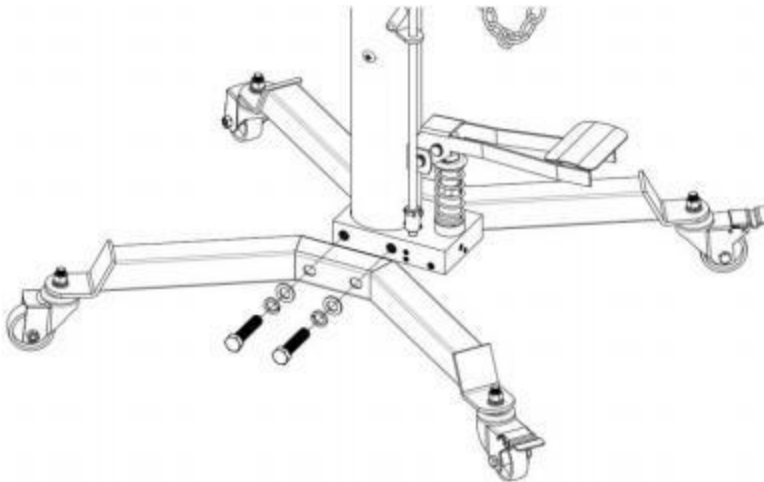

Step 3: Install the pedal above the pump body (using external pliers)

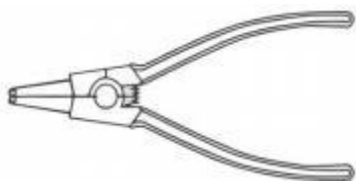
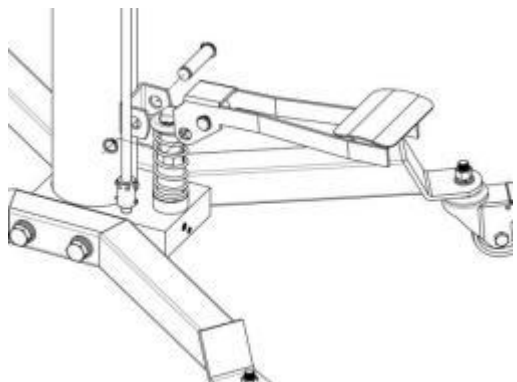

External Pliers

Step 4: Trap the handle over the cylinder

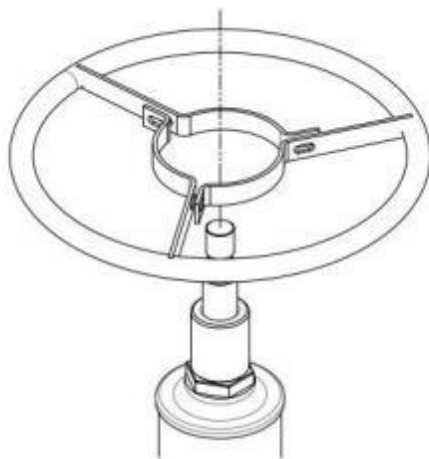



Step 5: Install handle ring screws (3 M8 \* 40 bolts, 3 M8 nuts, need a 14mm open wrench or a 14mm socket wrench)

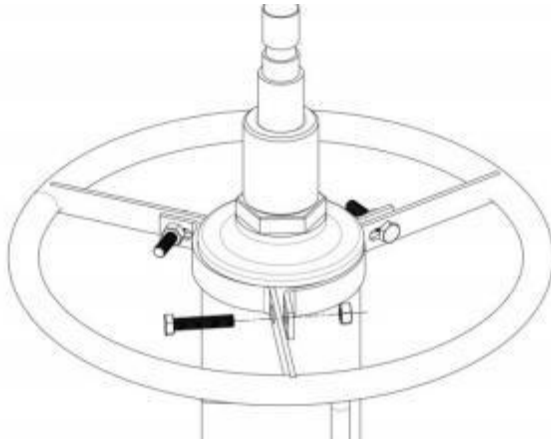

Step 6: Install the tray (saddle) on the oil cylinder



**For more detailed installation steps, please refer to the video on the website.**

## **5. Instructions of use**

### **1) RAISING THE JACK**

1. Before use, ensure the transmission weight and size does not exceed the capacity of the jack.
2. Ensure the vehicle from which the gearbox be removed is correctly positioned.
3. Check handbrake is applied and raised to allow the transmission jack to be positioned correctly.
4. Ensure there are no other persons around or under the vehicle.
5. Ensure saddle is in its lowest position and use handle to transport and centrally position jack beneath vehicle transmission.
6. Assemble the handle, ensure it aligns with slots.
7. Close the release valve by turning it clockwise until it is firmly closed.
8. Pump handle to lift until saddle contacts load. Continue to pump the jack handle to lift the vehicle to the desired height.
9. After lifting, support the load appropriately before removing transmission.

### **2) LOWERING THE JACK**

1. Support the load with appropriate means before removing transmission. Check to make sure the transmission is stable on the jack saddle and the load is fixed in place before attempting to lift, lower, or transport.
2. Grasp the handle firmly with both hands. Securely hold on to the jack handle so your hands do not slip and ensure the release valve does not rapidly lower.
3. Carefully open the Release Valve by slowly turning the handle counterclockwise. (Do not allow bystanders around the jack or under the load when lowering the jack.)
4. Lower saddle to the lowest height before attempting to transport load.

### **3) TRANSPORTING THE LOAD**

1. Ensure the jack saddle is fully lowered and load is secure before

attempting to lift, lower, or transport transmission.

2. Transport the load over level and solid ground, preferably concrete, and ensure the floor is swept clean before transporting load.

3. Be diligent in continually monitoring the load in transit. Keep all other persons at a safe distance.

4. DO NOT use on asphalt, or any soft surface as jack may sink or tip, causing damage to transmission or personal or injury/harm may result.

5. WARNING: If jack tips or leans STOP WHAT YOU ARE DOING. MOVE QUICKLY TO A SAFE DISTANCE. DO NOT TRY TO HOLD OR STEADY JACK to prevent personal injury and/or property damage.

#### **4) RE-INSTALLING A GEARBOX**

1. Ensure the jack saddle is fully lowered and load is secure before attempting to lift or transport transmission.

2. Transport the load over level and solid ground, preferably concrete, and ensure the floor is swept clean before transporting load.

3. Be diligent in continually monitoring the load in transit. Keep all other persons at a safe distance.

4. DO NOT use on asphalt, or any soft surface as jack may sink or tip, causing damage to transmission or personal injury/harm may result.

## **MAINTENANCE INSTRUCTIONS**

### **1) Inspection**

You should inspect the product for damage, wear, broken or missing parts (e.g.:pins)and that all components function before each use.

### **2) Binding**

If the product binds while under a load, use equipment with equal or a larger load capacity to lower the load safely to the ground.

After un-binding; clean, lubricate and test that equipment is working properly. Rusty components, dirt, or worn parts can be causes of binding  
Clean and lubricate the equipment as indicated in the lubrication section.

Test the equipment by lifting without a load. If the binding continues contact Customer Service.

### **3) Lubrication**

This equipment will not operate safely without proper lubrication. Using the equipment without proper lubrication will result in poor performance and damage to the equipment. Some parts in this equipment are not self-lubricating; inspect the equipment before use and lubricate when necessary. After cleaning, lubricate the equipment using light penetrating oil, or a lubricating spray.

- Use a good lubricant on all moving parts.
- For light duty use lubrication once a month.
- For heavy and constant use, lubrication is recommended every week.
- NEVER USE SANDPAPER OR ABRASIVE MATERIAL ON THESE

SURFACES!

### **4) Rust Prevention:**

- Check ram's and pump plungers on the power unit assemblies daily for any signs of rust or corrosion. Without a load lift the equipment as high as it goes and look under and behind the lifting points. If signs of rust are visible clean as needed.

### **5) Storing the Jack**

1. Lower the Lifting Arm.
2. Place the handle in the upright position.
3. Store in a dry location, recommended indoors.

Note: If the jack is stored outdoors, be sure to lubricate all parts before and after use to ensure the jack stays in good working condition.

## **6. Scope of application**

Use for the transportation of all kinds of automobile gearbox, transmission shaft, front and rear axles, etc

## 7. Common fault analysis

fault phenomenon	failure cause	solution
The ladder deformation	The actual load weight exceeds the maximum product load	In use, the actual load weight does not exceed the maximum product load

**Address:** Baoshanqu Shuangchenglu 803long 11hao 1602A-1609shi  
Shanghai

**Imported to AUS:** SIHAO PTY LTD, 1 ROKEVA STREET EASTWOOD  
NSW 2122 Australia

**Imported to USA:** Sanven Technology Ltd.

**Address:** Suite 250, 9166 Anaheim Place, Rancho Cucamonga, CA  
91730



Pooledas Group Ltd  
Unit 5 Albert Edward House, The Pavilions  
Preston, United Kingdom



SHUNSHUN GmbH  
Römeräcker 9 Z2021, 76351  
Linkenheim-Hochstetten, Germany

**Made In China**

**VEVOR<sup>®</sup>**

**TOUGH TOOLS, HALF PRICE**

**TechnicalSupport and E-Warranty Certificate**

**[www.vevor.com/support](http://www.vevor.com/support)**