

S3018 Pro CNC Engraving Machine

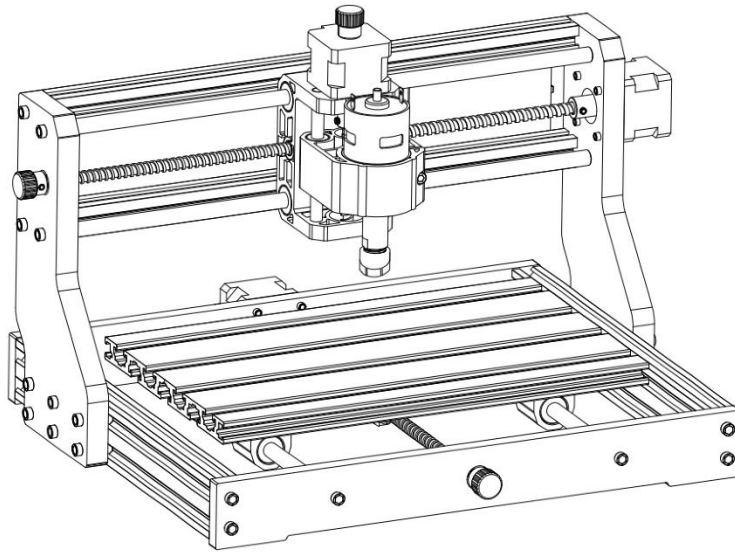

Catalog

- 1. Part List.....2
- 2. Machine Assembly.....3
- 3. Control board and Laser.....6
- 4. Candle Software.....6
- 5. Laser Grbl Software.....9
- 6. Offline Controller11
- 7. Restore factory settings.....12
- 8. Online guide and video.....12

Scan for videos and guides



Important Safety Instructions

Warning: To reduce the risk of burns, electrocutions, or injury to persons!



Avoid direct laser radiation on eyes or skin



Do not touch any rotating parts when the machine is running



Always wear protective glasses when use the machine



Prohibited from use in flammable objects or gases



Do not touch the socket with wet hand to reduce risk of electrocutions



Please cut off the power immediately in case of emergency

Statement

Original instructions for S3018 Pro, Please read all manual instructions carefully before operating. VEVOR reserves clear interpretation of our user manual. The appearance of the product shall be subject to the product you received. Please forgive us that we won't inform you again if there is any technology or software updates on our product.

Manufacturer:













Kunshan Boye Electronic Technology Co., Ltd

Address:









Room 4, No. 777, Jimingtang South Road, Huaqiao Town, Kunshan City, Jiangsu Province, China

1.Parts List



2018Pro Parts List				
Part No	Part Name	Explanation	Quantity	Picture
01	Aluminum profile	15180*300mm	1	
02	Aluminum profile	2020*370mm,Black	2	
03	Aluminum profile	2040*295mm,Black	2	
04	Connecting plate (font)	Black bakelite	1	
05	Connecting plate (back)	Black bakelite	1	
06	Connecting plate (left)	Black bakelite	1	
07	Connecting plate (right)	Black bakelite	1	
08	X Smooth axis	Φ10*370mm	2	
09	Y Smooth axis	Φ10*295mm	2	
10	X Lead screw	T8*393mm	1	
11	Y Lead screw	T8*308mm	1	
A	Component	Already assembled	1 Set	
12	T8 Nut (X/Y)	—	2	
13	Stepper motor	42HD	2	
14	Muff coupling (X/Y)	Φ8-Φ5	2 Set	
15	Nut support seat (Y)	T8	1	
16	Guide block (Y)	—	4	
17	Spring	Φ10.5	2	
18	Hand knob (X/Y)	Φ8*18mm	2	
19	Hand knob (Z)	Φ5*18mm	1	
20	Inner hexagon screw	M5*16	12	
21	Inner hexagon screw	M5*20	20	
22	Inner hexagon screw	M3*14	4	
23	Inner hexagon screw	M3*18	4	
24	Inner hexagon screw	M6*12	10	
25	Trapezoidal nut	M5-20	12	
26	Trapezoidal nut	M6-30	10	
27	Set Screw for knob	M4*5	3	
28	ER11	C16-ER11-35L 5mm	1 Set	
29	Milling cutter	—	1 Set	
30	Fixture	—	4 Set	
31	Inner Hexagon Wrench	2/2.5/3/4/5mm	1 Set	
32	Nut Wrench	14# / 17mm	1 Set	
33	Soft brush	—	1	
34	U Disk	—	1	

Component A (Already assembled)				
Part No	Part Name	Explanation	Quantity	Picture
A1	Guide block (X)	—	1	
A2	Guide block (Z)	—	1	
A3	T8 Nut (Z)	T8*15mm	1	
A4	Z Lead screw	T8*88mm	1	
A5	Z Smooth axis	Φ8*92mm	2	
A6	Stepper motor	42HD	1	
A7	Inner hexagon screw	M3*10	4	
A8	Spindle motor	775	1	
A9	Inner hexagon screw	M4*30	1	
A10	Square Nut	M4*2.5mm	1	
A11	Inner hexagon screw	M3*18	4	
14	Muff coupling(Z)	Φ8-Φ5	1 Set	
17	Spring	Φ10.5	1	





Control board package

Part No	Part Name	Explanation	Quantity	Picture
C1	Control board	VIGO	1	
C2	Column	PA,M5*3	4	
C3	Inner hexagon screw	M5*10	4	
C4	Ship nut	M5-10	4	
C5	Stepper motor wire	4P	3	
C6	Spindle motor wire	2P	1	
C7	Offline controller and date cable	Optional	1 Set	
C8	USB cable	—	1	
C9	Power supply	24V,5A	1	

Laser package (Optional)

Part No	Part Name	Explanation	Quantity	Picture
L1	Laser kit	Optional	1 Set	
L2	Laser wire	3P	1	
L3	Protective glass	Optional	1	

Fixture (30) assembly

Part No	Part Name	Explanation	Quantity	Picture
30-1	Pressing plate	50*20	4 PCS	
30-2	Screw	M6*40	4 PCS	
30-3	Screw	M6*45	4 PCS	
30-4	Butterfly nut	M6	4 PCS	
30-5	Washer	M6*2mm	4 PCS	

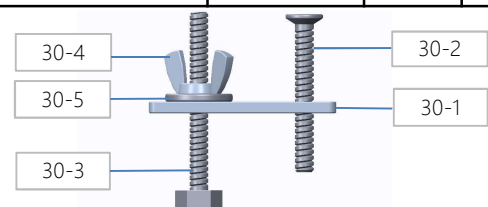

2. Machine Assembly

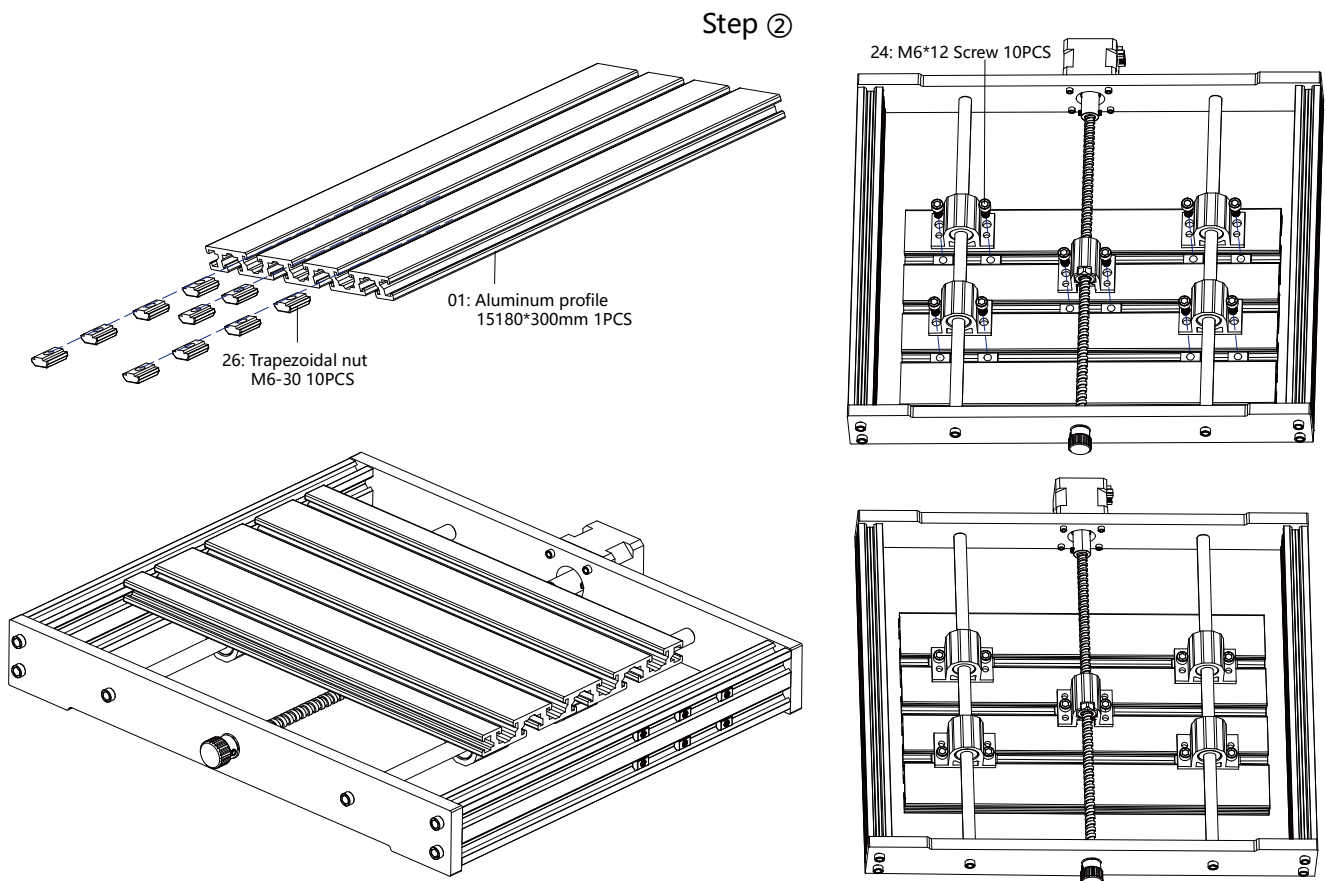
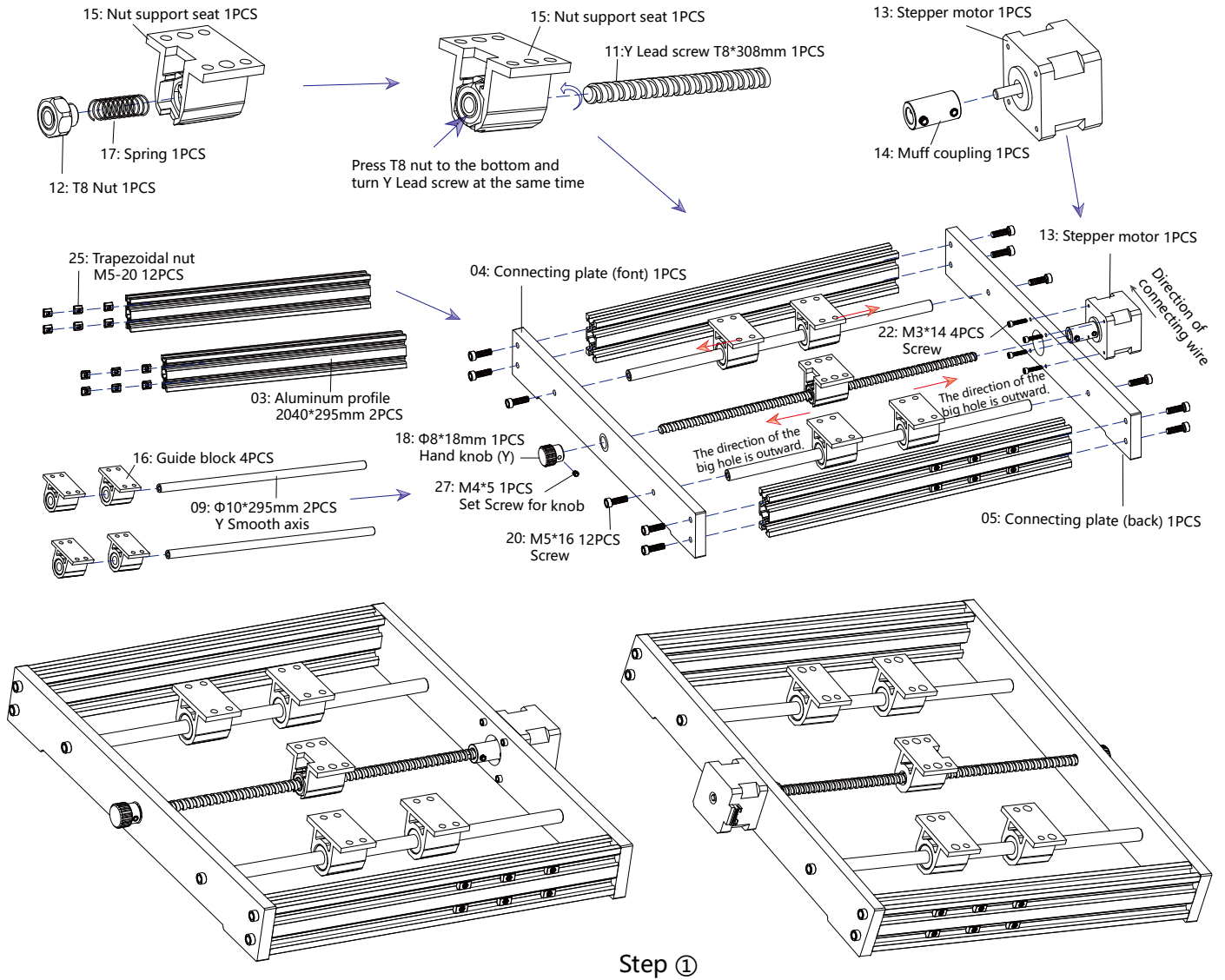

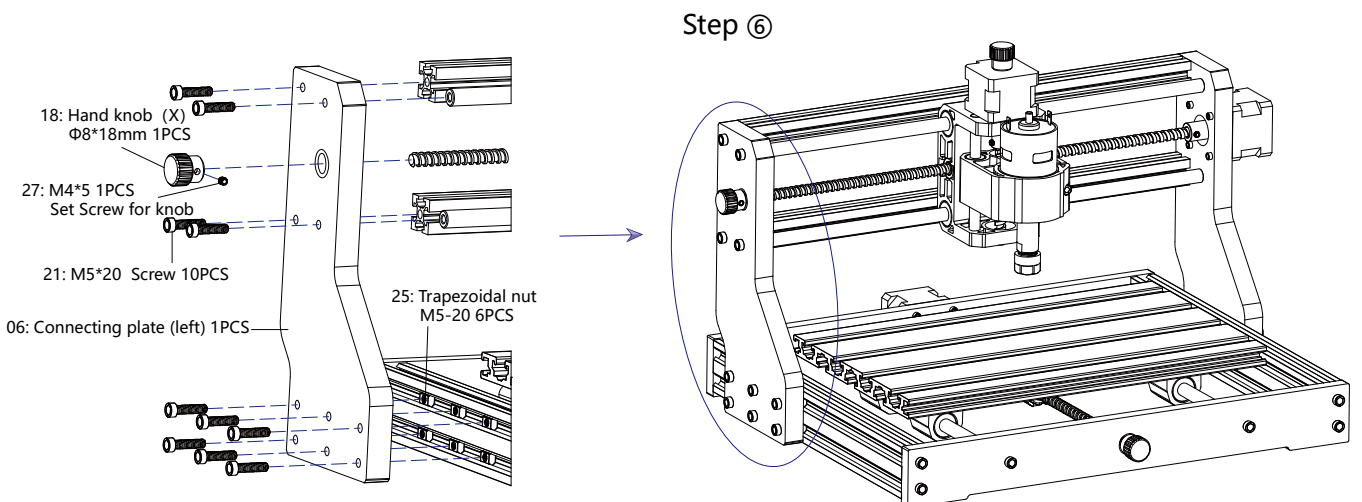
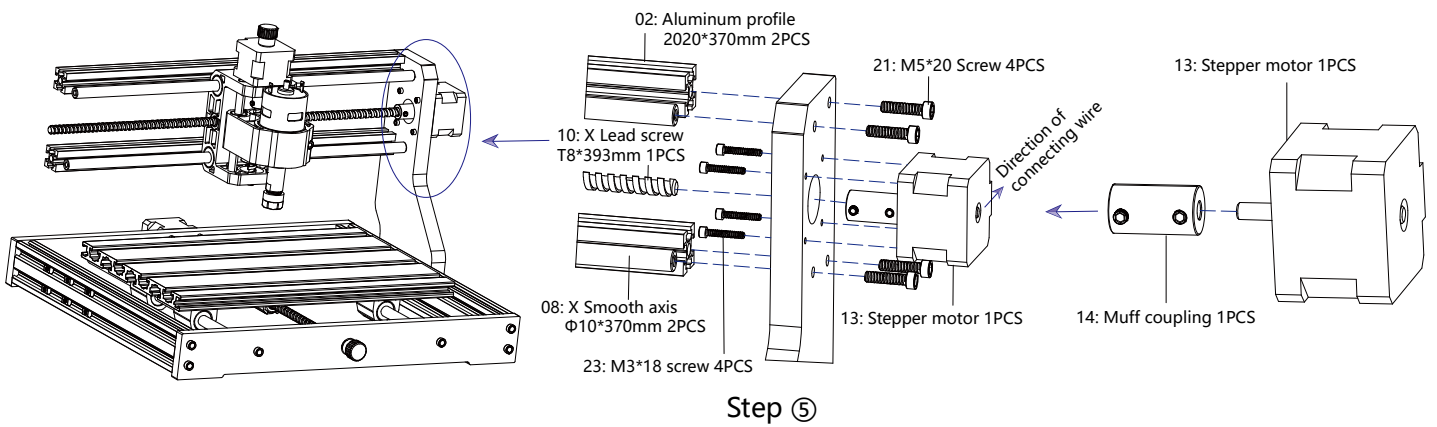
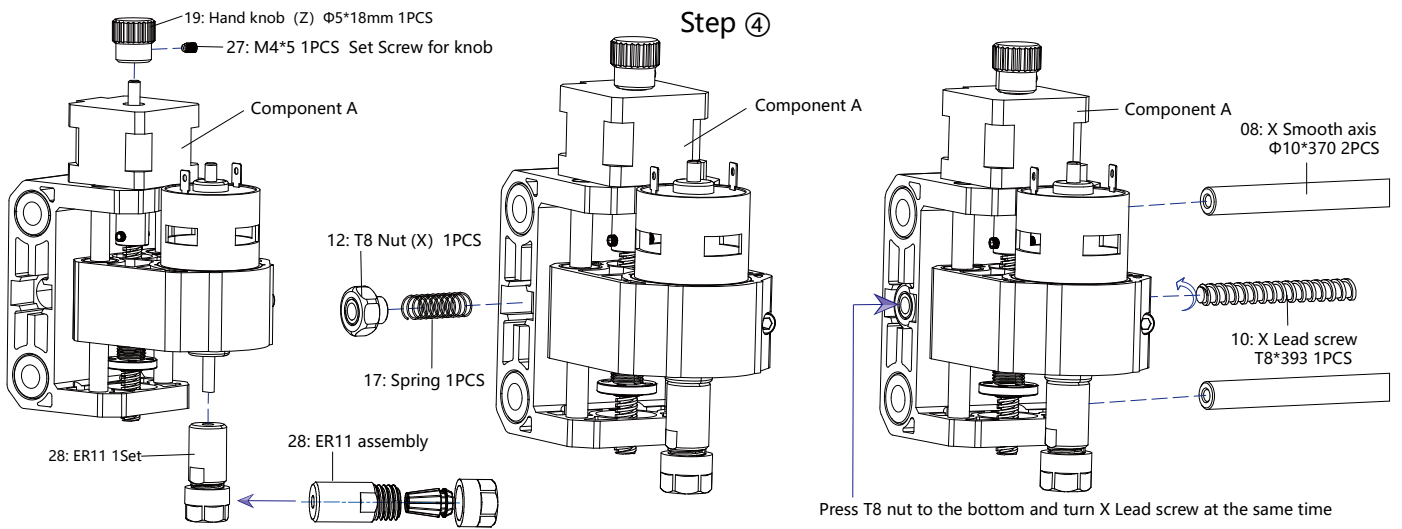
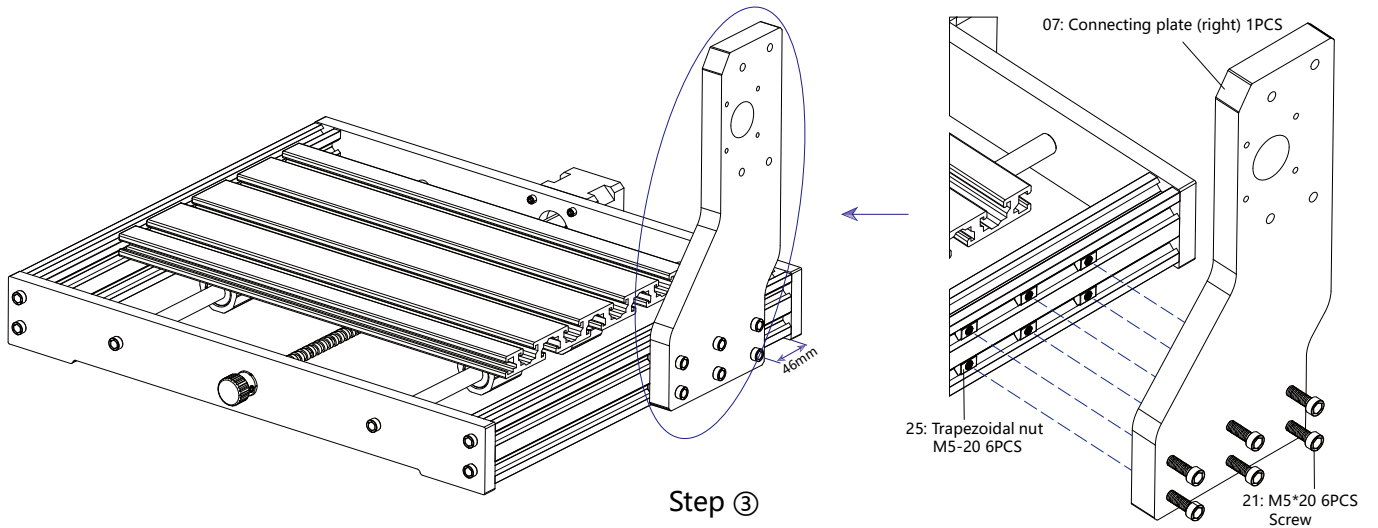

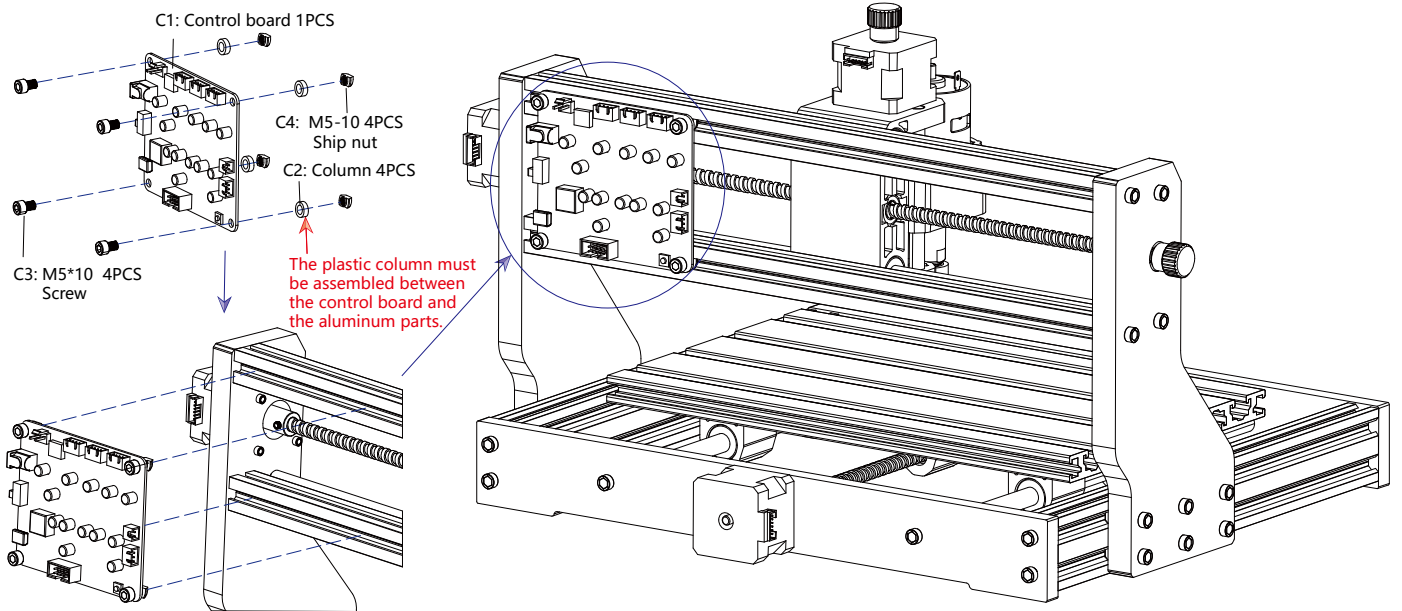

Step ⑦

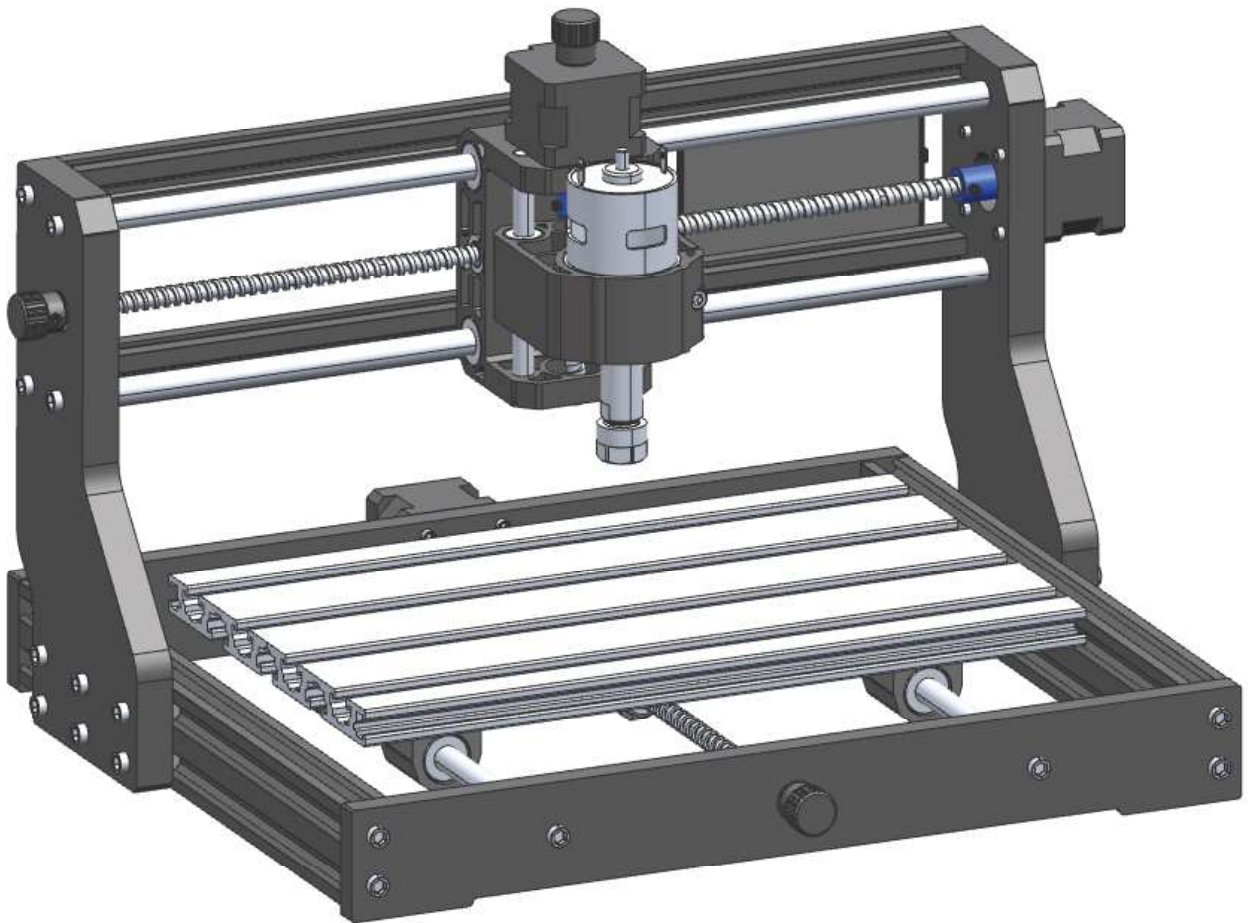

3. Control-Board and Laser (Laser is optional)

3.1 Instructions for control board connection

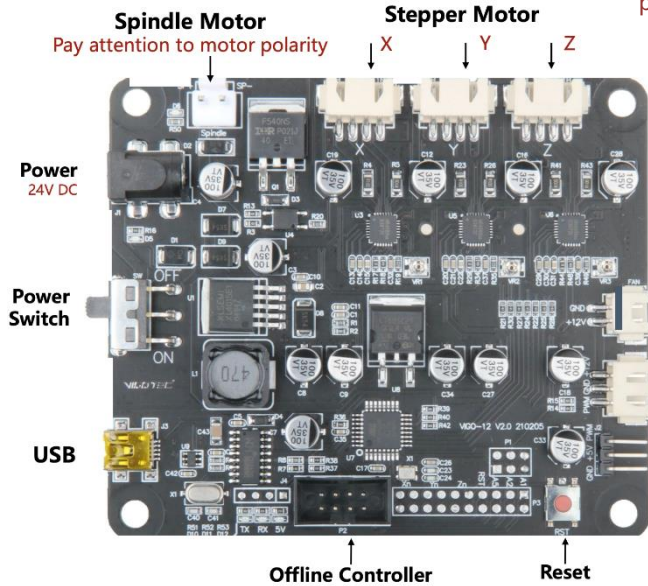

The terminal of the red dot of the spindle motor is positive, please plug in the red wire.



The Motor-X/Y/Z interface on board should be connected to the X/Y/Z motors correspondingly. The 6Pin plug is for the motor, and the 4Pin is for the control panel. Power interface connects to the power supply and USB connects to the computer. Connect the spindle motor wire according to the correct polarity.

In general, there is no need to adjust the motor driver current.

If using laser, please connect the laser to the control board with the 3pin wire. Correctly focus the laser on the materials to be engraved referring to the laser instructions below before starting engraving.



XTS05
XTS08
XTS10
Is adjustable

Focusing Ring



XTS15 Laser
Is adjustable

Focusing Ring



XTS15D Laser
Is fixed-focus
Can't be adjusted

Focusing Column

3.2 Instructions for laser (Optional).

Please wear the protective glasses before operating the laser!

When all the connections are completed, turn on the power, and the laser is standby for working. The red light on the top of the laser is continuous lighting in this time.

Turn on the weak light and adjust the focal length (except the Fixed-Focus Laser)

Please lay the materials to be engraved flat under the laser. The recommended distance from laser outlet to materials is 3~10cm. Out of range may be out of focus.

Turn on the weak light. Rotate the focusing ring slowly on the laser outlet to shrink the laser spots. When the laser spot is smallest and clearest, it is the optimum state for laser engraving, then turn off the weak light.

If you use the fixed-focus laser XTS15D, please use the focusing measuring column to adjust the distance between the light outlet and the engraved surface to 18mm.

Note: Laser XTS05/XTS08/XTS10 have a weak light switch on top of the lasers, you also can use the switch to turn on weak light. Be sure to turn of the switch before you start laser engraving.

4. Candle Software

Candle is a GUI application for GRBL-based CNC-machines with G-Code visualizer. Candle is an open-source software suitable for CNC machine tool processing. It supports G code file processing and visual display.

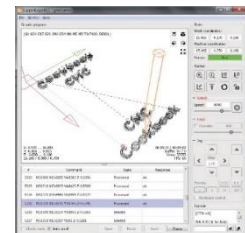

Supported functions:

- (1) Controlling GRBL-based CNC-machine via console commands, buttons on form, numpad.
- (2) Monitoring CNC-machine state.
- (3) Load, edit, save and send G-code files to CNC-machine.
- (4) Visualizing G-code files.

4.1 States

Work coordinates:
Represents current X, Y & Z local coordinates of the CNC.

Machine coordinates:
Represents current X, Y & Z absolute machine coordinates.

- One of following CNC status:
- Idle - waiting for a G-code command
 - Running - running a G-code command
 - Home - homing cycle is executing
 - Check - G-code command check mode is turned on
 - Hold - paused by a "!" command, need to be restarted by a "~" command
 - Alarm - CNC doesn't know where it is and blocks all G-code commands

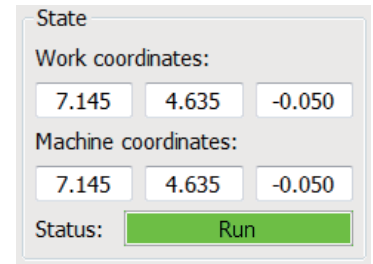

4.2 Control

Home button
Starts the homing cycle procedure with "\$H" command

Z-probe
Starts the zero Z-axis search procedure using the command specified in the settings ("Z-probe commands" box). Example command: G91G21; G38.2Z-30F100; G0Z1; G38.2Z-1F10

Zero X/Y
Zeroes the "X" and "Y" coordinates in the local coordinate system. Also retains an local system offset ("G92") for later use.

Restore X/Y/Z
Restores local system coordinates with "G92" command.

Safe Z
Moves tool by "Z"-axis to safe position. Position coordinate can be specified in the "Safe Z" setting. Position must be specified in machine coordinates.

Reset
Resets CNC with "CTRL+X" command

Unlock
Unlocks CNC with "\$X" command.



4.3 Software using steps

(1). Install the driver

For the first time use, please connect the device to the computer via USB cable, and click the **CH341SER.exe** file in the driver folder to install the driver. Under normal circumstances, the Win10 system will automatically identify and install the driver. For Win7 and Win8 systems, please install it manually.

(2) Set the port and connection

After installing the driver, open the device manager of the computer and click on the port option to see the content inside the red box on the screen shown in the figure below (the port information is in brackets).

Remember the port information queried above, switch to the **Candle** software interface and click the "Settings" option in the upper left corner. Selecting the setting will pop up the setting window. Under "Connection", select the port name you queried, select the baud rate 115200, and then click the "ok" to finish the setting.

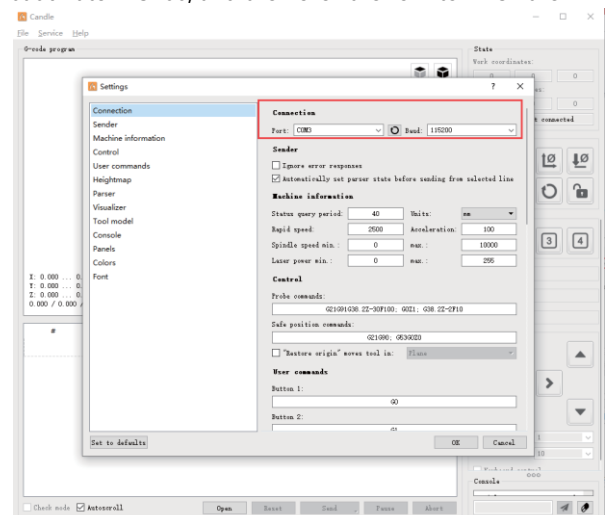
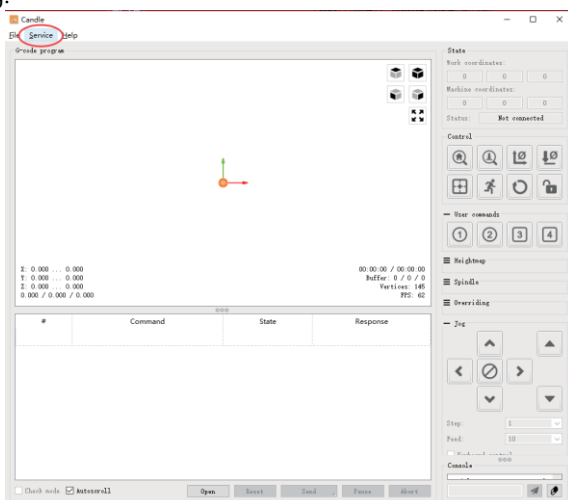

(3). Complete connection

After setting the port and baud rate, click Finish. The status bar at the top right of the Candle interface will show Idle, and at the same time, the console at the bottom right will display the information shown below, indicating that the connection has been successfully established.

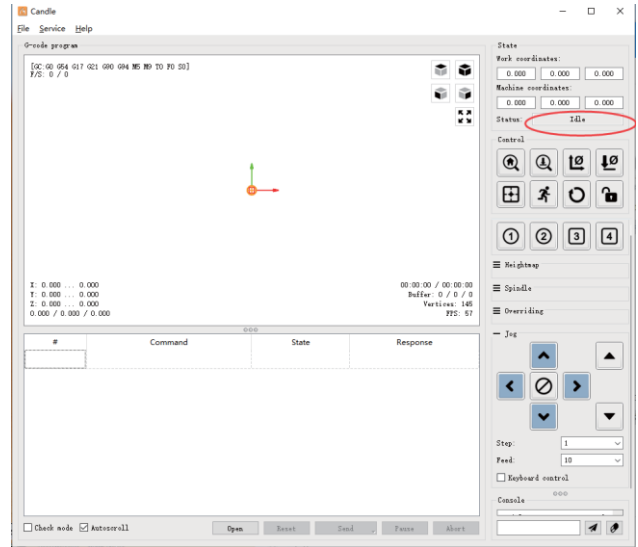

(4). Processing documents

Click "File" option at the top of candle, then click "New" to create G-Code. On the command bar at the bottom of the interface, click "Open" to select a G code file that has been made to import the file. After importing, the middle of the interface will display a visual graph composed of tool paths (the position of the pen-shaped graph in the graph is the current tool position). In the visualization window, hold down the left mouse button to move to rotate the graph, and hold down the right button to move. Graphics, scrolling the middle wheel to zoom in and out of the graphics. At the same time, the content of the G-Code will be displayed in the lower command bar. During processing, the machine will run one by one according to the G-Code commands.

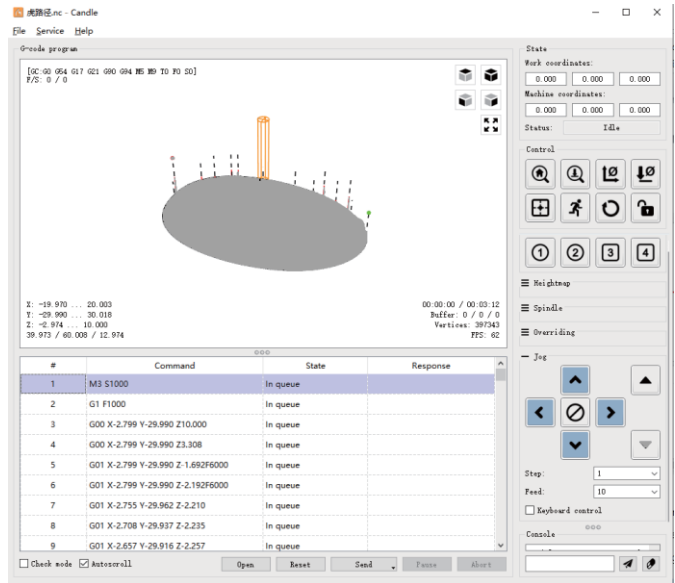
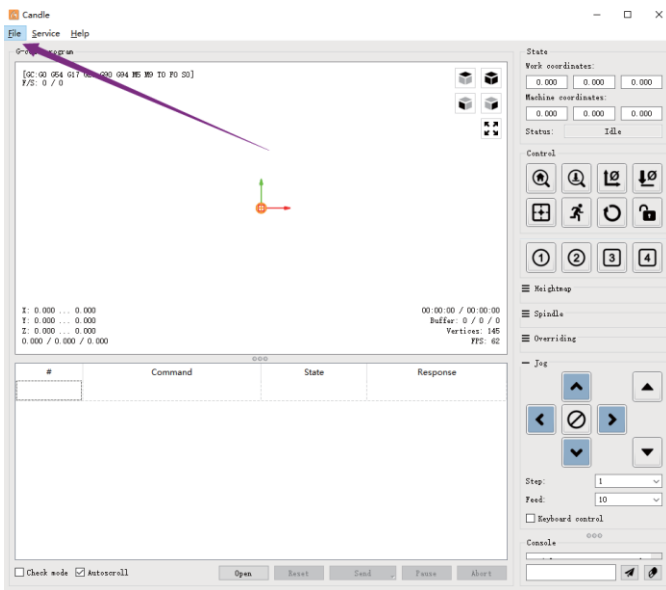



(5). Fixture, tool installation and Set the working coordinate origin

The fixture in the product kit is not assembled. There are four sets in total. The appearance and usage of the assembled fixture are shown in the right figures.

Before running the G code program, you need to find the position of the engraving figure relative to the overall engraving plate. There is a three-axis coordinate system in the visual graphics. The origin of the three-axis coordinate system is the tool setting point of the actual processing graphic.

You can move the tool to determine the position of the engraving graphic relative to the overall engraving plate based on the position of this origin. The engraving figure in the figure below is taken as an example.



After the selected tool position is started, the X/Y and Z axes are reset to zero (the   are zeroing X/Y and Z axes buttons). Before returning to zero, make sure that the tool approaches the distance of one sheet of paper for engraving, and then return the X/Y and Z axes to zero (please use a flat-bottom sharp knife when engraving, and use a cylindrical milling cutter when machining planes, slots, and holes) The effect is that the sculpted figure will be carved with the blade tip as the origin.

The ER11 collet on the spindle motor should be clamped into the fixed head first, and it must be clamped in place. When installing the cutter, please do not extend the collet too much, as shown in the first figure below.

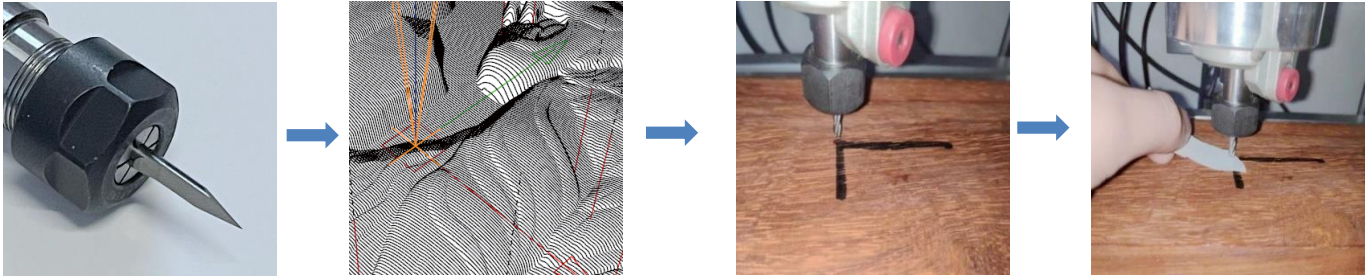

(6) Start carving

After finding the engraving position, click the send button below and the device will automatically start engraving. The status bar at the top right shows running. The visualization window shows that the tool is moving along the tool path. You can choose the pause and stop buttons below when engraving. (After pausing, click again to continue the previous carving. After termination, click Send to start processing from the beginning).

(7). Finished processing

After the processing is completed, the visualization window prompts that the engraving is completed and the time required for carving.

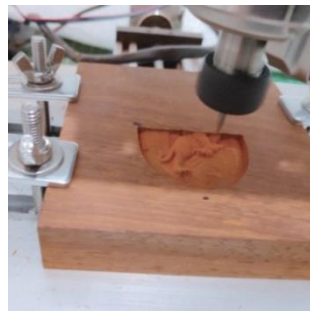
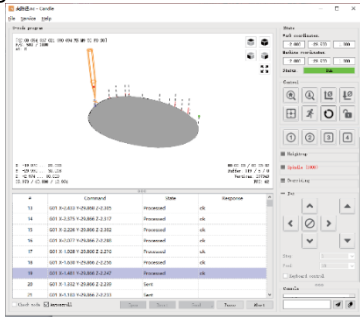

5. Laser GRBL software

Laser GRBL is an excellent and practical opening source controls software in the field of laser engraving. Compared with similar software, it has a simple interface, simple operation, and supports multiple languages. There are a lot of learning resources used on the Internet, which is convenient for beginners to understand and master the software. Mastering a laser engraving software is the basic condition for using laser engraving machine. It is recommended that beginners first learn the operation method of the software online before using it to prevent damage to the laser engraving machine and surrounding items by improper operation.

5.1 Download and installation

Download from Laser GRBL official website or find in the USB-disk contains two files:

- (1) CH341SER.EXE, USB driver Unzip the package and find the file **CH341SER.exe**. Double-click to install, the user needs to install this driver when running the software for the first time.
- (2) LaserGRBL, software locate the file (install.exe) in the archive, double-click it to install it.

5.2 Online operation steps

Online operation is the operation of controlling the device through software after the device is connected to the computer.

- (1). Connect the device to the computer with a USB cable.
- (2). Place the material to be engraved in the working area of the engraving machine. Turn on the weak light, focus by rotating the laser focus knob until the spot becomes smallest and clearest, then the focus is complete.
- (3) Open the Laser GRBL software, select the COM port (except COM1, you can plug and unplug the USB cable to see which one is) and the baud rate (generally set to 115200), then click the connection, the color of the button will become darker after the connection is successful (if Click the connect button and the color does not become darker. You can unplug the USB cable and plug it in again.)
- (4). After the connection is successful, click "File" on the menu bar of the interface to enter the selection file interface, select "Open File", import the picture to be engraved, etc.

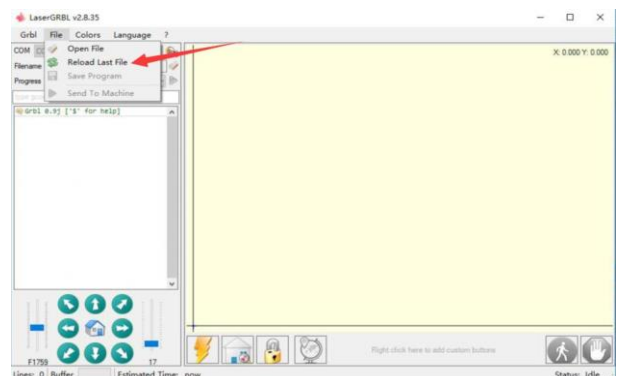
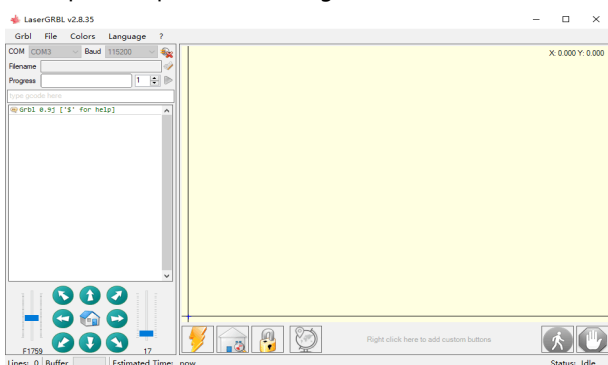

(5). Select the file to be engraved, click "Open", the "Input Raster Image" dialog box will pop up. Here is the setting engraving mode and some other engraving parameters. Click "Next" after setting.

(6). Click "Next" to pop up the "Target Image" dialog box, where you can set the engraving speed, minimum power and maximum power and the length and width of the image to be engraved and offset. Click "Create" after setting.

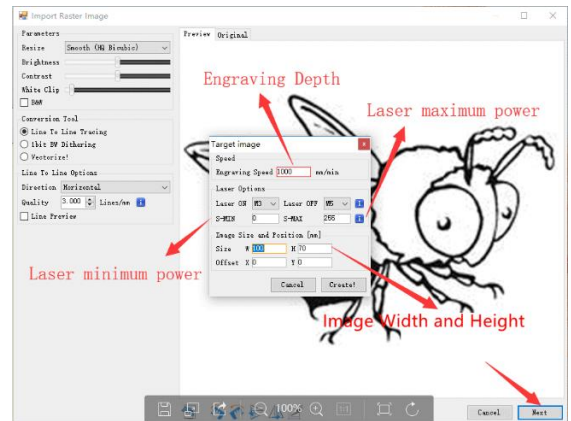
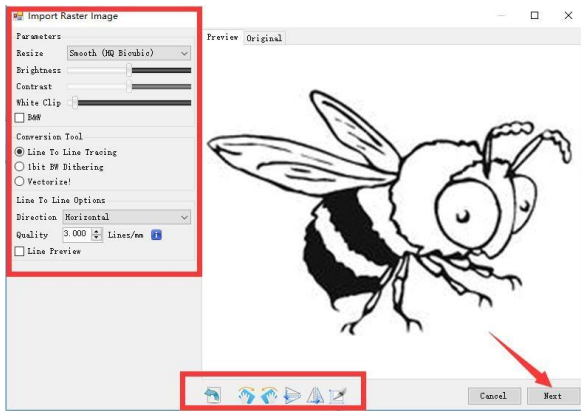

(7). After clicking "Create", enter the preparation for engraving.

Move to the position you want to engrave, click the "Position" button (the position where the laser head is located at the lower left corner of the engraved pattern), set the number of times to be engraved, and click the "Start Engraving" button to start the engraving. After the engraving is completed, the machine returns to the zero position.

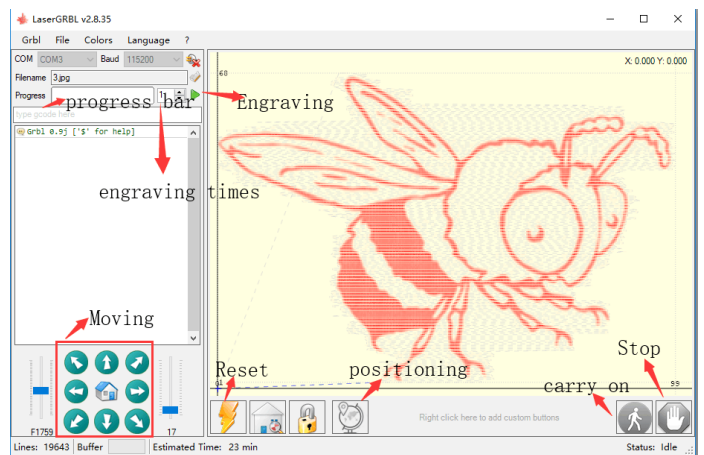

5.3 About Engraving effect

In general, the use of relatively high power, the engraving depth is relatively deep, but due to the focal length, it will be less detailed than the low power. Small power engraving is shallow but very fine. When engraving, you can adjust the power, engraving speed, and moving speed for better results. In addition, when the speed is slow, it can be cut, but if the edge is not fine and the degree of burning is obvious, you can try to adjust the speed and repeat the engraving several times to achieve better results. If it is cutting, please adjust the speed as appropriate to achieve the cutting effect. If it is engraving, please adjust the parameters such as power and speed according to the depth of engraving.

5.4 FAQ

Q: What's the difference between different power levels?

The higher the power, the greater the luminous energy of the laser head, the higher the temperature of the material hit, the harder the material of the material that can be engraved, and even the full cutting can achieve the cutting effect. If cutting, it is recommended to choose high power; if it is required to engrave shallower, more delicate, it is recommended to choose low power.

Q: Which formats are supported?

Support all formats of images, support GCODE, NC files and so on. If you want to engrave .DXF file, we recommend the LightBurn software.

Q: Does it support the grayscale engraving function?

Supports the grayscale engraving function, which can engrave pictures and photos of different shades of color by controlling the intensity of the laser according to the color depth of the image.

Q: What is the reason that the engraved picture is very light?

Quality: ** line / mm, generally set to 10 lines / mm, the larger the value, the darker the color, the set according to your needs
 Engraving speed: the moving speed when the laser is turned on, the faster the speed is engraved the shallower. Minimum maximum power: The general minimum power is set to 0 and the maximum power is set to 1000. The greater the maximum power, the deeper the engraved color.

Q: Why does the fan of the laser module not turn?

Please confirm that the laser head is working properly. If the laser head does not work, there may be a bad contact of the power supply line of the laser head; if the laser head works normally, the fan may be broken.

Q: What is the reason for the software connection failed?

Please confirm whether the USB interface is in connect with normal. Please confirm whether the COM port is selected correctly (do not select COM1); please confirm whether the baud rate is selected correctly (select 115200).

Q: How long does it take to engrave a picture?

The length of time required for engraving depends mainly on the speed of the engraving, the speed of the idling, and the size of the picture. Users can view the total time spent on the software.

6. Offline controller (Optional)

Note: The offline controller and the computer cannot be connected to the engraving machine at the same time. When using the offline controller, please make sure that the USB cable of the machine and the computer is disconnected.

The off-line controller has an external 12V standby power supply interface. When users use other mainboards with no power supply and weak power supply capacity, they can connect an external power supply to supply power to the controller

6.1 Main page:

Y-: right **Y+:** left **Z+:** Send \$X to the GRBL motherboard to unlock it.

OK/SPN: Confirm button.

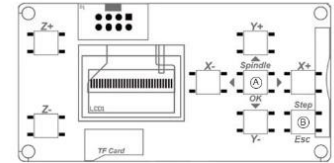
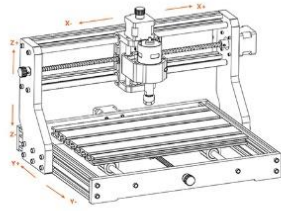

6.2 Control page:

Manually move each axis to the desired position.

X+: X axis move right direction, **X-** opposite. **Y+:** Y axis move forward direction, **Y-** opposite. **Z+:** Z axis move up direction, **Z-** opposite.

OK/SPN: Spindle test switch, press to open the spindle (corresponding to SPN gray on the screen), press again to close the spindle (the corresponding SPN on the screen returns to normal). Long press to enter changing spindle speed page. At this page, **Y+ / Y-** is High/Low spindle speed, long press **OK/SPN** to exit the changing spindle speed page.

Exit/STP: Function 1: Tap on each axis button of XYZ to change the movement distance by 0.1, 1, 5, 10 cycles each time. Function 2: Press and hold for about 2 seconds to exit.

6.3 File page:

File list Select the file to be engraved. Support documents include: NC, NCC, TAP, TXT, Gcode, GCO, NL, CUT, CNC .

Y+: up, **Y-:** down

OK/SPN: Confirm the selection and enter the confirmation engraving page.

6.4 Confirm the engraving page:

Confirm that the engraving file is started without errors.

OK/SPN: Confirmation starts, ready to print becomes the progress display percentage, the file selection page is returned after the engraving is completed.

6.5 Settings page:

X+ / X-: Chang Baud rate; **Y+ / Y-:** Change Feed rate by ± 100/Click; **Z+ / Z-:** Change Feed rate by ±10/Click; **OK/SPN:** Change Laser Mode ON/OFF

6.6 Wi-Fi Network and Web

The offline controller has WiFi wireless network function. By default, the WiFi hotspot of VIGO-STK**** is automatically established. You can connect to the hotspot through the WiFi of your computer or mobile phone with password **12345678**, and then open **192.168.0.1** or **vigostick.local** in browser to manage (upload or delete) the files on the SD card of the offline controller, and you can also enter the SSID (Only support 2.4G signal) account and password to help the offline controller access your local WiFi network. After the controller is connected to the local 2.4G WiFi, the current IP address of the controller or the domain name

Main page

Control

Move Page

X+ Y+ Z+ SPN

X- Y- Z- X1

Function	Key
Move X Y Z:	X+ X- Y+ Y- Z+ Z-
Spindle on/off:	A(Spindle)
Step:	B(Step)
Back:	B(Esc(long press))

File

IPHONE-1.NC

File Select

Ready To Print

Confirm

Printed: 1%

Running

Setting

Baud rate	Feed rate	Laser Mode
115200	(100-2000)mm/min	ON OFF

Turn on the laser mode for laser engraving
Turn off the laser mode for CNC tools carving

STKAJBJ

MENU

Control

File

Settings

About

STATUS

CONNECTED

System Idle

MOVE

Z+

Y+

SPN+

X-

SPN:ON

X+

Z-

Y-

2

SPN-

Only 2.4G Wlan is supported by this controller and usually the name without *5G*

vigostick.local can still be opened to enter the web management interface. You can open **About** page of the controller to check the IP address.

Network status: There is a dot in the upper left corner of the main page. The **RED** dot indicates that VIGO-STK**** hotspot is active, and the **GREEN** dot indicates that the controller has connected to Local WiFi.

The web management interface is as previous page. The web pages functions as follows:

Click the menu "**Control**", the MOVE Control interface appears, you can click the corresponding button to control the CNC machine movement.

Click the menu "**File**", shows the carving files currently stored in the SD card of the current offline controller. You can upload new files to the controller. After selecting the corresponding carving file to start the carving, the interface displays the file being carved and the carving progress. You can click the button to pause or stop the carving process.

Click the menu "**Settings**", enter the carving machine setting interface, where you can set some control parameters, or perform reset, unlock, restore settings, tools setting, turn on/off laser mode and other commands.

6.7 Laser Engraving App

The offline controller support mobile laser engraving App (For Android and iOS). Before using the App, please turn on the laser mode in settings of the controller. Turn off the laser mode when you use CNC tools. Please get the VevorWorks App form our website www.VevorEngraver.com ,or scan the right QR-code to download.



App supports Android and IOS. It can import mobile phone pictures, take photos with mobile camera, edit graphics and text, generate engraving content, support gray, black and white, contour and other engraving modes, and control engraving in real time.

7. FAQ

Q: How to use the lasers

A: 1. For XTS05/XTS08/XTS10/XTS15 laser, please place the material flat under the laser, and make the distance between them within 3~10cm (Less distance will not be able to focus). Turn on the weak light, then there will be a light spot on the material, just turn around the focus ring on laser to adjust the spot become smallest and clearest, which means the best focus.

2. XTS15D laser is fixed focus laser which is not adjustable. The fixed focal Length is 18mm. Please use the focusing column to determine the distance from the engraved object to the top surface of copper ring of light outlet.

Q: Laser module can't burn anything, no light, weak power.

A: 1. Please check power, speed setting on software and adjust focus length for laser [refer to 3.2 above to adjust focus].

Q: The picture engraved is the opposite of the original picture

A: Just need to adjust on software [Reversal X/Y axis]

Q: The picture engraved distortion.

A: The screw rod and motor shaft are not locked and slipping.

8. Restore factory settings

If the mechanical movement of the machine is smooth, but the engraving movement appears stuck, or the stepper motor does not move, please try to restore the factory settings of the main-board.

Method: Run Candle software and send command **\$RST=*** to the machine, then reboot the machine.

9. Assembly video and online guide



Please scan the QR code below to watch the machine assembly video. **If the U disk in the machine kit can't be read, please scan the QR code to see how to download the software and related documents.**

EU Importer: WAITCHX
 Address: 250 bis boulevard Saint-Germain 75007 Paris
UK Importer: FREE MOOD LTD
 Address: 2 Holywell Lane, London, England, EC2A 3ET

EC	REP	EUREP GmbH Unterlettenweg 1a, 85051 Ingolstadt, Germany
UK	REP	EUREP UK LTD UNIT 2264, 100 OCK STREET, ABINGDON OXFORDSHIRE ENGLAND OX14 5DH

www.vevor.com
 Contact: service@vevor.com
 Call us:
 (+626) 275-4507 (For USA)
 (+44) 1173182739 (For Europe)
 (+001) 626 275-4507 (For Other Countries)
 Working Time: Mon-Fri 8:00am to 5:00pm

