

# **VEVOR<sup>®</sup>**

**TOUGH TOOLS, HALF PRICE**

Technical Support and E-Warranty Certificate <https://www.vevor.com/support>

## **LIFTING FLAT TABLE USER MANUAL**

We continue to be committed to provide you tools with competitive price.

"Save Half", "Half Price" or any other similar expressions used by us only represents an estimate of savings you might benefit from buying certain tools with us compared to the major top brands and does not necessarily mean to cover all categories of tools offered by us. You are kindly reminded to verify carefully when you are placing an order with us if you are actually saving half in comparison with the top major brands.

# VEVOR®

TOUGH TOOLS, HALF PRICE

## Lifting Flat Table

MODEL NO.: ZWE-DDJ-SS-11, ZWE-DDJ-SS-12

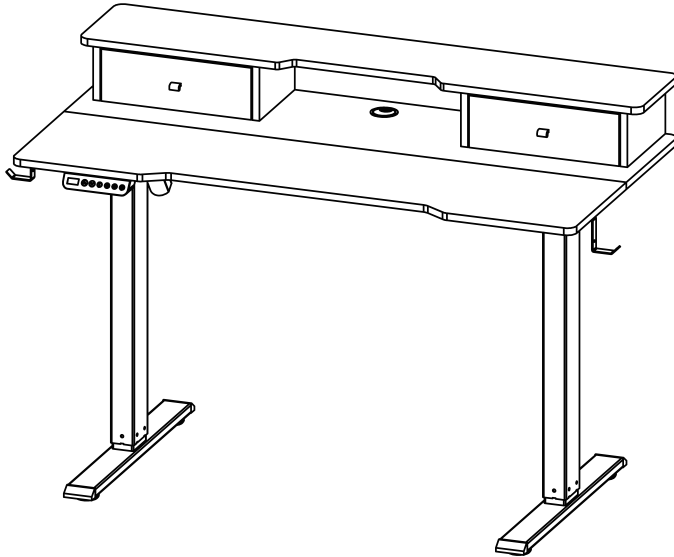

### NEED HELP? CONTACT US!

Have product questions? Need technical support? Please feel free to contact us:

 [CustomerService@vevor.com](mailto:CustomerService@vevor.com)

This is the original instruction, please read all manual instructions carefully before operating. VEVOR reserves a clear interpretation of our user manual. The appearance of the product shall be subject to the product you received. Please forgive us that we won't inform you again if there are any technology or software updates on our product.

 **WARNING:**

**Please read this manual carefully before using the product. Failure to do so may result in serious injury. SAVE THIS MANUAL**

## **ASSEMBLY PRECAUTIONS**

1. Assemble only according to these instructions. Improper assembly can create hazards.
2. Wear ANSI-approved safety goggles and heavy-duty work gloves during assembly.
3. Keep the assembly area clean and well-lit.
4. Keep bystanders out of the area during assembly.
5. Do not assemble when tired or when under the influence of alcohol, drugs, or medication.
6. The product capabilities apply to properly and completely assembled products only.
7. Assemble on a flat, level, hard, and smooth surface capable of safely supporting the Lifting Flat Table.
8. For additional information regarding the parts listed in the following pages, please refer to the Assembly Diagram of this manual. Unwrap and separate all parts on a clear work area.

## **USE PRECAUTIONS**

### **TO PREVENT SERIOUS INJURY AND DEATH FROM TIPPING:**

1. This product is not a toy. Do not allow children to play with or approach this item.
2. Use as intended only. Do not sit or stand on the table.
3. Inspect before every use. Do not use it if parts are loose or damaged.
4. Use only on flat, level, and hard surfaces.







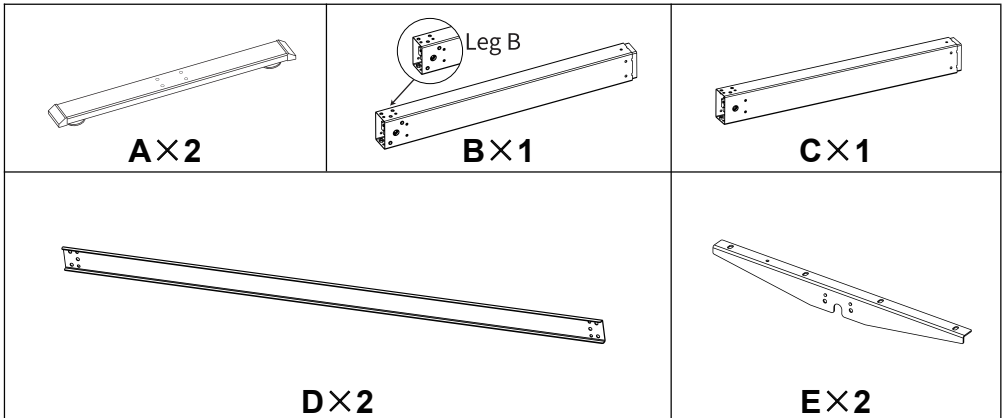



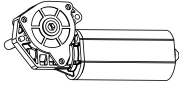
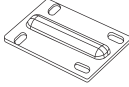

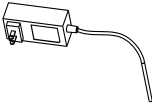

# TECHNICAL SPECIFICATIONS

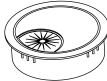
Model	ZWE-DDJ-SS-11 ZWE-DDJ-SS-12
Adapter Rating(s)	100-240V~, 50/60Hz, 1.5A
Main Material	Steel + Board
Color	Brown + Black
Product Dimensions (LxWxH)	1200 x 600 x 1270 mm
Packing Size (LxWxH)	1285 x 380 x 150 mm
Net Weight (kg)	29.2
Gross Weight (kg)	31.2

# PACKAGE CONTENTS

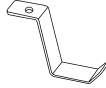



 <p><b>H×1</b></p>	 <p><b>I × 1</b></p>	
 <p><b>J × 3</b></p>	 <p><b>K×4</b></p>	 <p><b>L×1</b></p>
 <p><b>M×1</b></p>	 <p>M6*13 <b>N×38</b></p>	 <p>ST4*12 <b>O×2</b></p>
 <p>M4*40 <b>P×2</b></p>	 <p>M6*35 <b>Q×8</b></p>	 <p><b>R×1</b></p>
 <p><b>S×1</b></p>	 <p><b>T×4</b></p>	 <p><b>U×1</b></p>
 <p><b>V×2</b></p>	 <p><b>W×4</b></p>	 <p><b>X×22</b></p>
 <p><b>Y×22</b></p>		

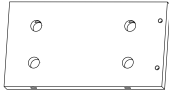

①×2

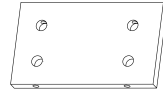

②×2

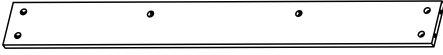

③×1



④×1

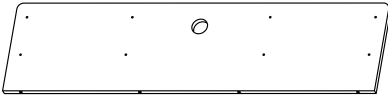

⑤×1

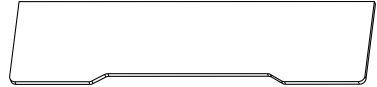

⑥×1

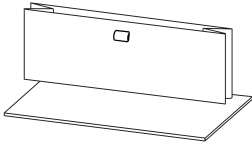

⑦×2

# ASSEMBLY STEPS

## STEP1 Foot installation

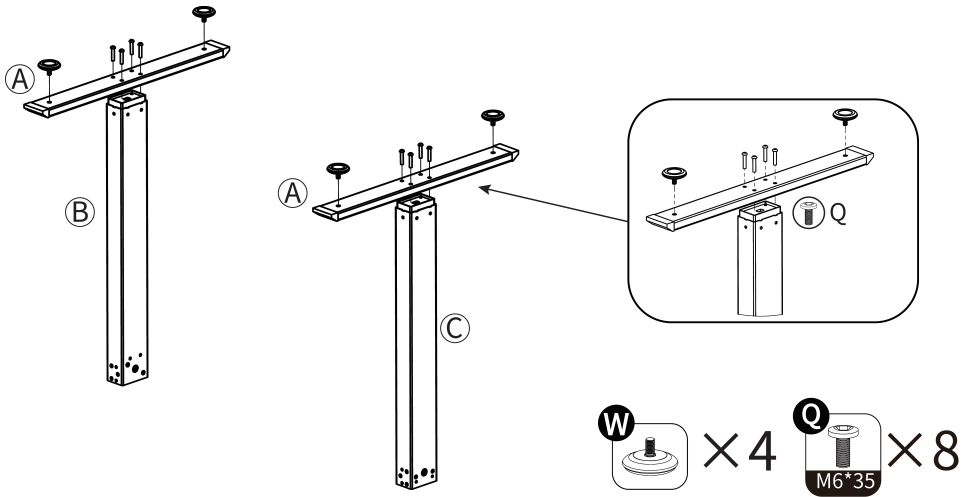

## STEP2 Motor installation

①

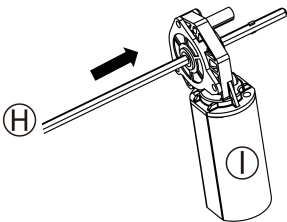

First, insert the motor from the end of the hexagonal rod without a bump to the other end with a bump.

②

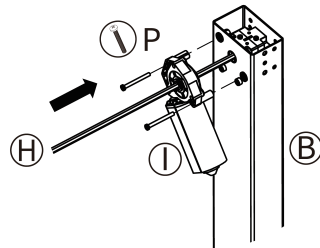

Then, insert the convex end of the motor into leg B together with the motor. Tighten the motor on leg B with the screws shown in the picture.



### STEP3 Drive rod installation

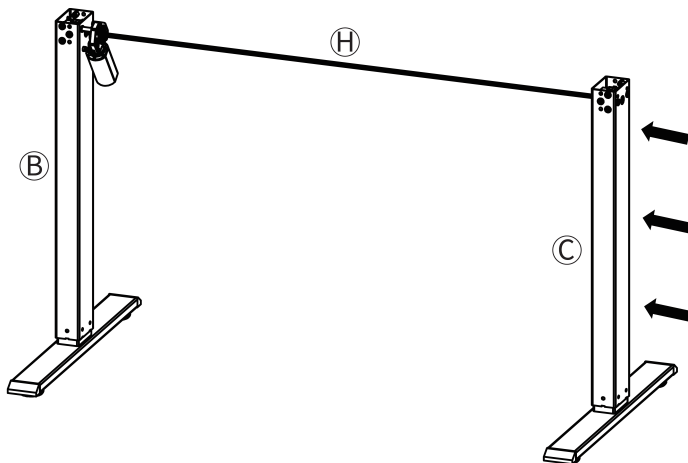

After completing the previous step, insert leg C into the hex stick.



If the holes are misaligned, hold the motor by hand and adjust the hex rod to rotate slightly so that the hex rod can be inserted into leg C.

### STEP4 Beam installation

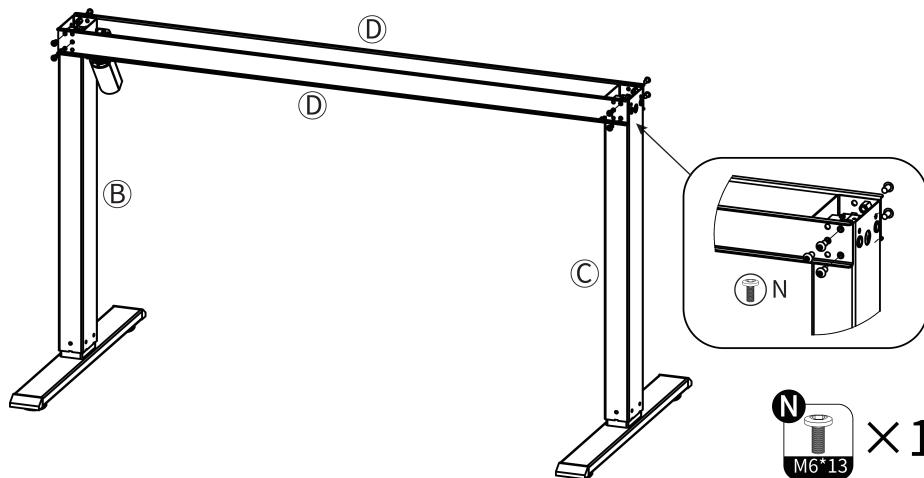

## STEP5 Side wing installation

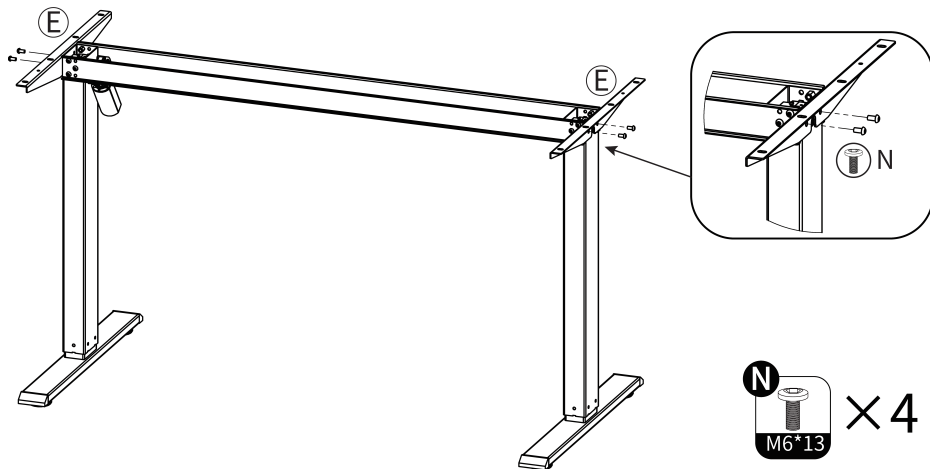

## STEP6 Panel splicing (1)

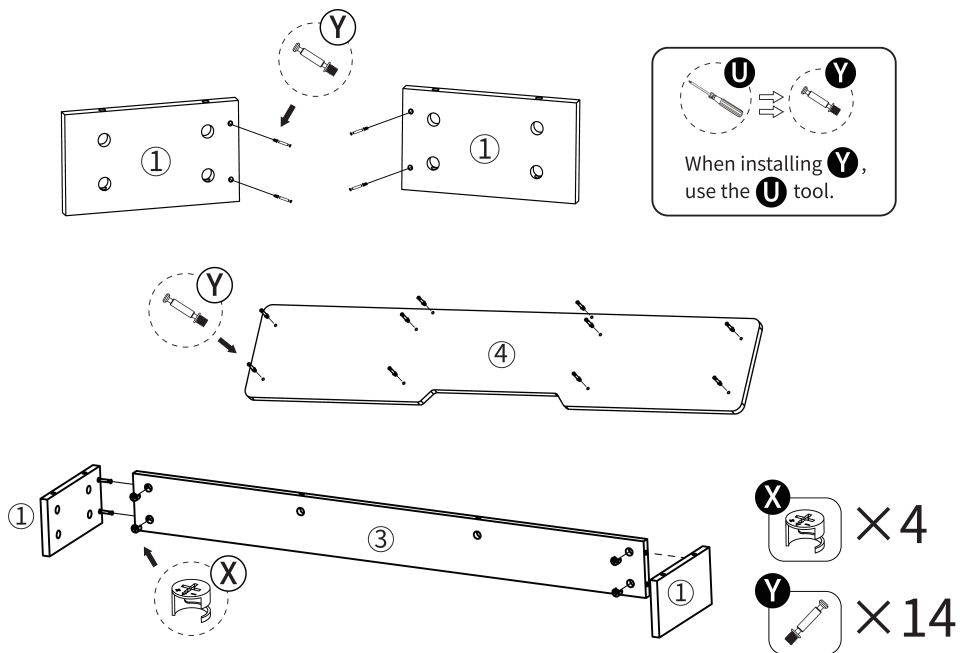

## STEP6 Panel splicing (2)

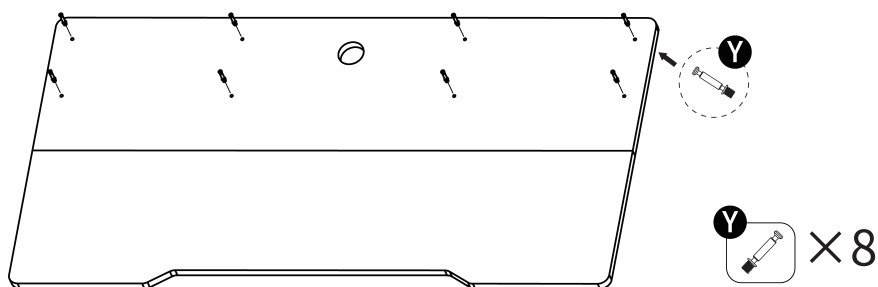
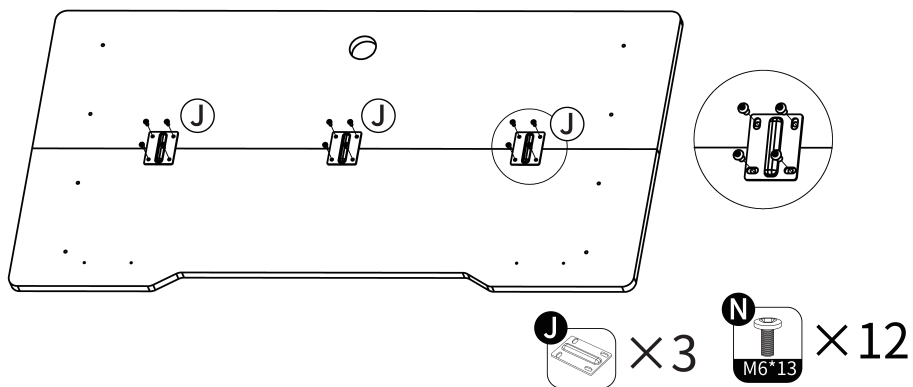
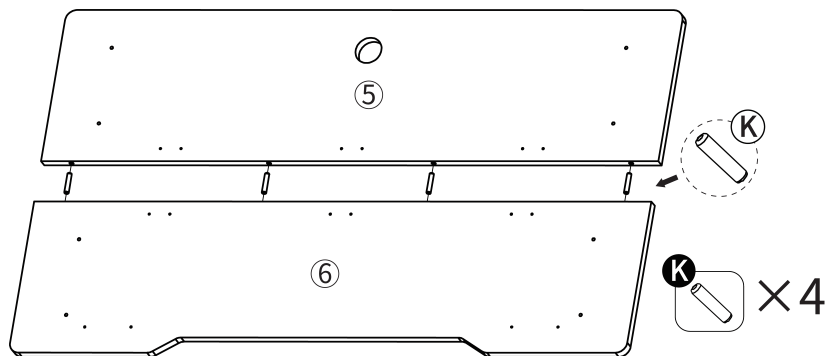

## STEP7 Bookshelf installation

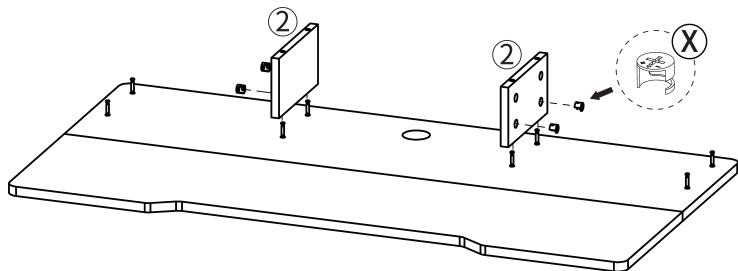

X × 4

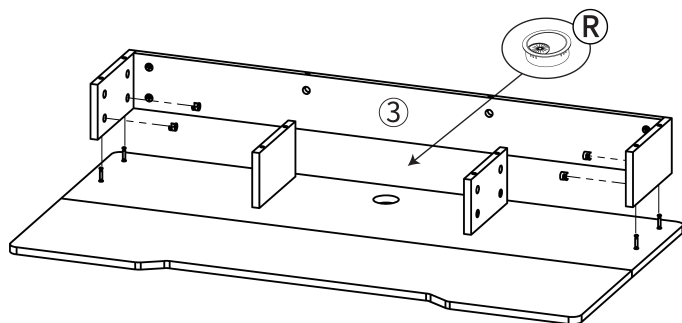

R × 1

X × 4

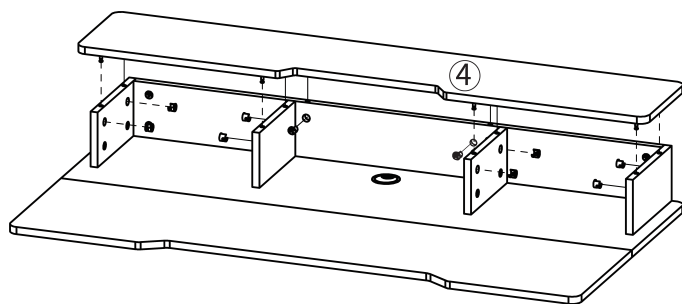

X × 10

## STEP8 Panel installation

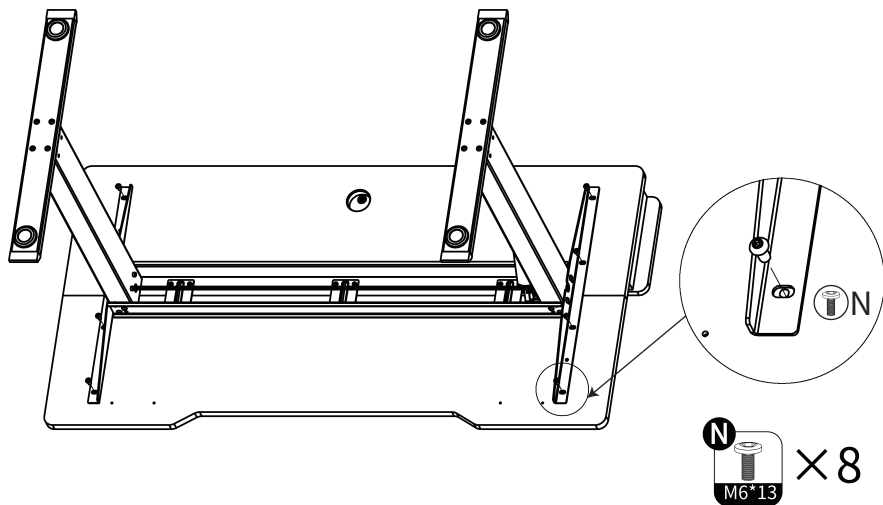

## STEP9 Accessories installation

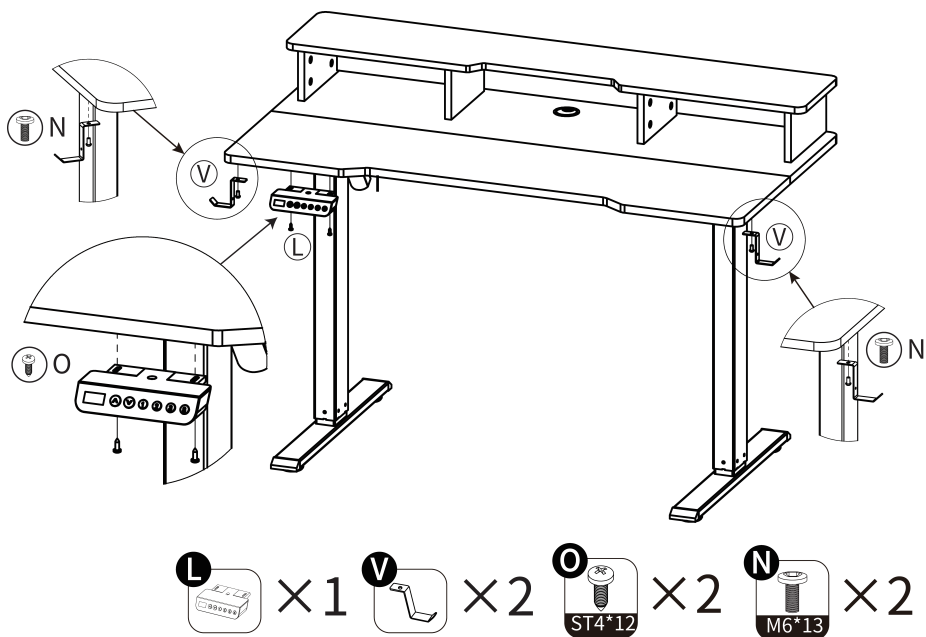



## STEP10 Line connection

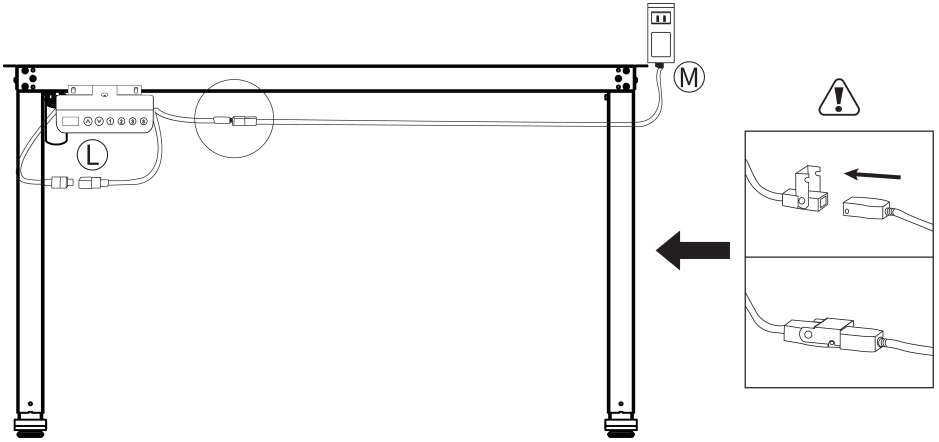

## STEP11 Drawer installation

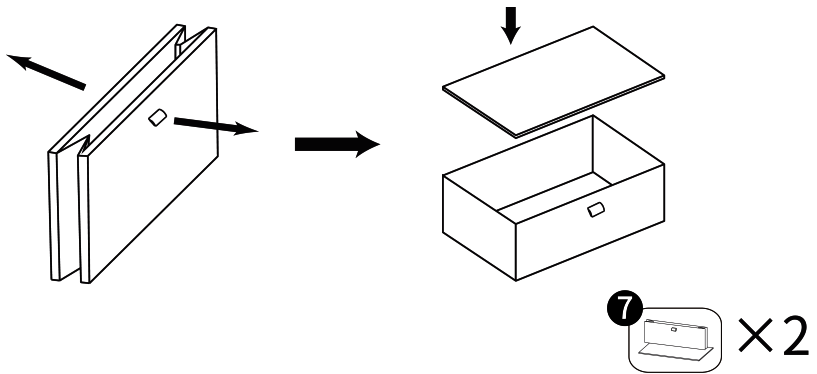

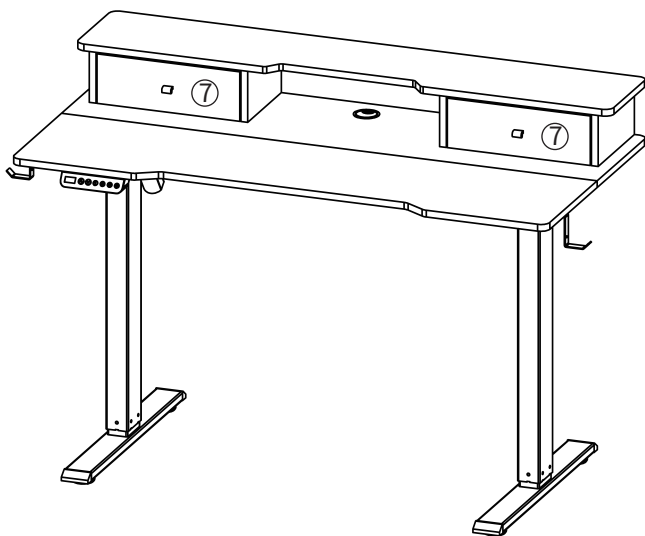





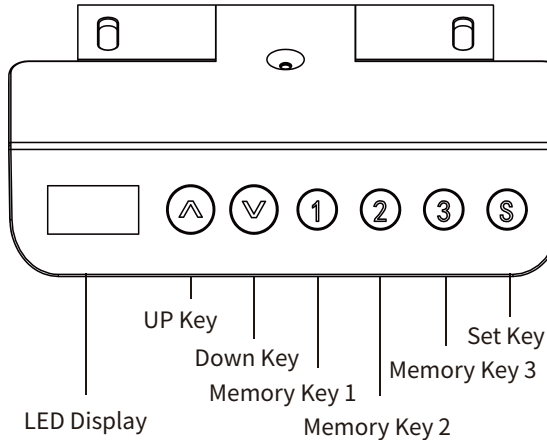

⚠ Insert the cloth drawer into the bookcase

# Height Adjustment Controller Operation



- LED Display:  
Press any key once to wake up the LED display.
- UP Key:   
Press and hold the UP key to raise the desk.
- Down Key:   
Press and hold the DOWN key to lower the desk.
- Memory Key:  
   

 You must complete the Initialization Process to reset your desk before using it for the first time.

## Detailed introduction of key functions

### Reset

After running to the lowest height position, press and hold for 7 seconds. When the LED screen "rst" and "E-1" flash alternately, release the ↓ key, and press and hold the key again. After the desktop runs down to the lowest mechanical zero point, go back 5mm, the LED screen displays the lowest height value, and the reset is completed.

### Set memory height + / /

Press the S key once, and the height value will start flashing. At this time, press the 1, 2, and 3 keys to save the current height to the corresponding position.

### Execute memory height

In normal state, press the number key to call up its corresponding height, and the lifting table will automatically run to the corresponding position.

### Lock key

Press and hold the S key for 3 seconds. When the LED screen displays "SET", learn to open the S key. Press the number key 3 to enter the lock screen state. At this time, the LED screen flashes and displays "OFF".

When the screen is locked, press and hold the S key for 3s, and the LED screen displays the height value. At this time, release the S key to complete the unlocking.

### Restore factory settings

Press and hold the S key for 9 seconds, release the S key when the LED screen displays "FAC", and operate the S key again to restore the factory settings.

## Error Code Instructions

Error Code	Reason	Solution
Err	Err is displayed when the communication line sequence between the manual controller and the control box is wrong	/
E-1	When the system does not save the current position, the LED screen flashes alternately to display "E-1"	Reset by pressing the long key until the LED screen displays the minimum height and the alarm is released
E-2	When the motor is locked, the LED displays E-2	/
E-5	When the motor appears: the connecting line is disconnected/loosened, the LED screen flashes alternately to display "E-5"	1. Check the connection lines between all motors and the controller to ensure that they are firm, and then reset by long pressing the down key until the LED screen displays the minimum height, and remove the alarm
ovr	When the load exceeds the set value, the LED screen flashes to display ovr. At this time, it is necessary to remove the weight of the desktop and power on the controller after powering off. This alarm can be relieved	1. Normal load shall be controlled below 120KG 2. When the current exceeds 4A, the overload protection function will be triggered
hot	When the internal temperature of the controller exceeds $60 \pm 5$ degrees, the LED displays hot	/

voL	When the input voltage of the controller exceeds 34V, the LED displays voL	<ol style="list-style-type: none"> <li>1. When the voltage exceeds 32V, the controller is powered off and the LED screen is black;</li> <li>2. When the voltage drops to 32V, the system will automatically reply and LDE will display the real-time height</li> </ol>
hot	After the motor runs continuously for 5min, the LED screen displays hot, and it can work normally after waiting for 10min	<ol style="list-style-type: none"> <li>1. Uninterrupted operation means that the operation interval is within 3s</li> <li>2. This alarm can also be removed when the control system is powered on again</li> </ol>
E-3	During the operation, when suddenly blocked, the LED screen flashes "E-3", stops the action and runs 30mm in the opposite direction, then the LED screen displays the real-time height	It shall be ensured that the table will not vibrate significantly, bump into obstacles or tilt during operation

# COMPLETION

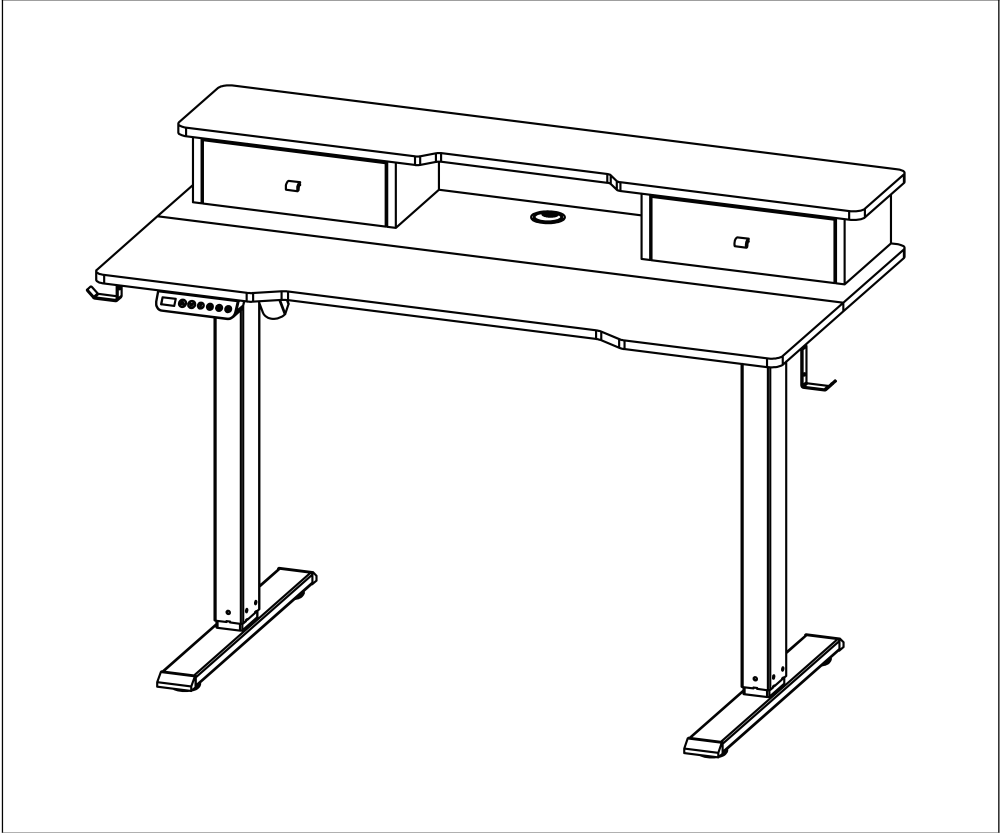

**Address:** Baoshanqu Shuangchenglu 803long 11hao 1602A-1609shi Shanghai

**Imported to USA:** VEVOR STORE INC, 9448 RINCHMOND PL #E

RANCHO CUCAMONGA, California, 91730 United States of America

<b>EC</b>	<b>REP</b>
-----------	------------

SHUNSHUN GmbH

Römeräcker 9 Z2021,76351

Linkenheim-Hochstetten, Germany

<b>UK</b>	<b>REP</b>
-----------	------------

Pooledas Group Ltd

Unit 5 Albert Edward House, The Pavilions

Preston, United Kingdom

**VEVOR**<sup>®</sup>

**TOUGH TOOLS, HALF PRICE**

**Support and E-Warranty Certificate <https://www.vevor.com/support>**