

VEVOR[®]

TOUGH TOOLS, HALF PRICE

Support and E-Warranty Certificate <https://www.vevor.com/support>

WIRE STRIPPING MACHINE INSTRUCTION MANUAL

We continue to be committed to providing you with tools at a competitive price. "Save Half",

"Half Price" or any other similar expressions used by us only represent an estimate of savings you might benefit from buying certain tools with us compared to the major top brands and do not necessarily mean to cover all categories of tools offered by us. You are kindly reminded to verify carefully when placing an order with us if you are actually saving half compared to the top major brands.

VEVOR®

TOUGH TOOLS, HALF PRICE

WIRE STRIPPING MACHINE

MODEL:SMS-025



NEED HELP? CONTACT US!

Have product questions? Need technical support? Please feel free to contact us:

✉ CustomerService@vevor.com

This is the original instruction, please read all manual instructions carefully before operating. VEVOR reserves a clear interpretation of our user manual. The appearance of the product shall be subject to the product you received. Please forgive us that we won't inform you again if there are any technology or software updates on our product.

Operation Guide Video



This is the original instruction, please read all manual instructions carefully before operating. VEVOR reserves a clear interpretation of our user manual. The appearance of the product shall be subject to the product you received. Please forgive us that we won't inform you again if there are any technology or software updates on our product.

WARNINGS

Read carefully and understand all ASSEMBLY AND OPERATION INSTRUCTION before operating. When using the wire stripping machine, basic safety precautions should always be followed, including the following:

1. Read and follow all instructions before using the machine.
2. To prevent the risk of electrical shock, do not immerse in water or other liquids. Use a damp cloth to clean the motor housing.
3. Children shall not play with the appliance. Cleaning and user maintenance shall not be done by children without supervision.
4. When not in use, unplug from the outlet before installing or removing parts and before cleaning.
5. Avoid contacting moving parts.
6. Do not operate any machine with a damaged cord or plug or after the appliance malfunctions or is dropped or damaged in any manner. Return the appliance to the nearest authorized service facility for examination, repair, or electrical or mechanical adjustment.
7. The use of attachments not sold by the manufacturer is not recommended and may cause fire, electric shock, or injury.
8. Do not use outdoors.
9. Do not allow the cord to hang over the edge of the table or counter.

10. Never run the machine unattended.

11. Type Y attachment: If the supply cord is damaged, it must be replaced by the manufacturer, its service agent, or similarly qualified persons in order to avoid a hazard.

TECHNICAL PARAMETER

Model	Dimension (L*W*H mm)	Weight (kg)	Voltage	Power (KW)	Stripping Range (mm)
SMS-025	318×250×300	10.8kg	220V-240V~ 50Hz	0.18	∅ 1.5~∅ 25
			110V~ 60Hz		

Note: This machine is not applicable to silicone rubber cables or armored cables.

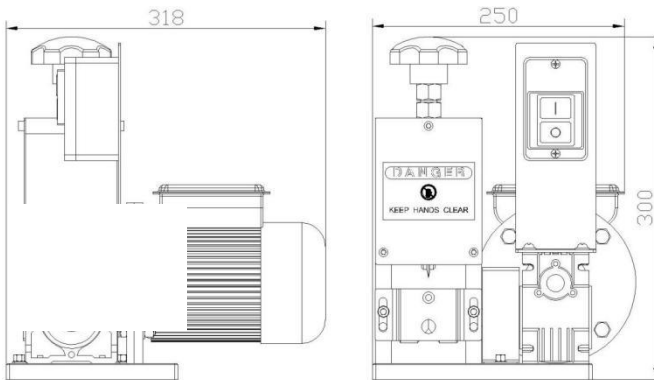

Parts List

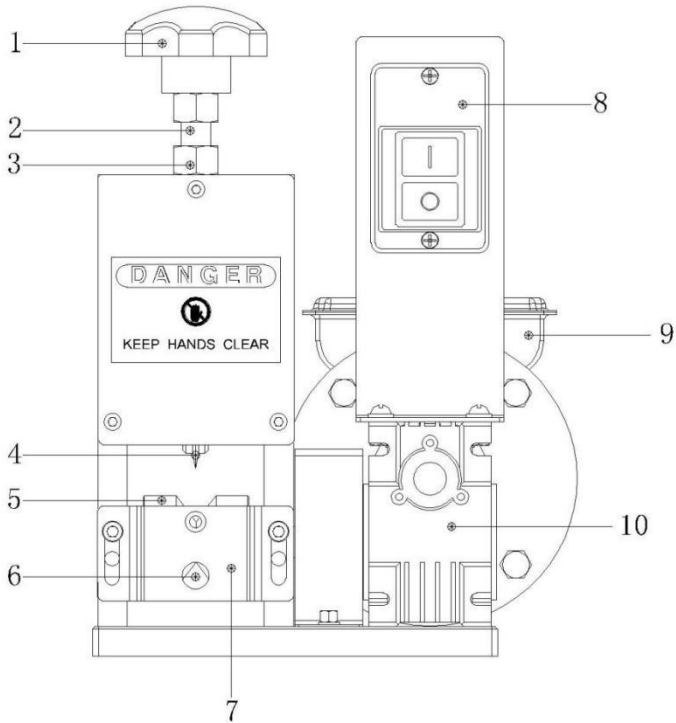

1:M14 plastic nut for regulating blade up and down

2:M14 screw rod for regulating blade up and down

3:Nut for locking screw rod

4:Blade

5:Rolling Gear

6:Feeding Hole

7:Incoming Panel

8:Switch

9:Motor

10:Reducer

Accessories

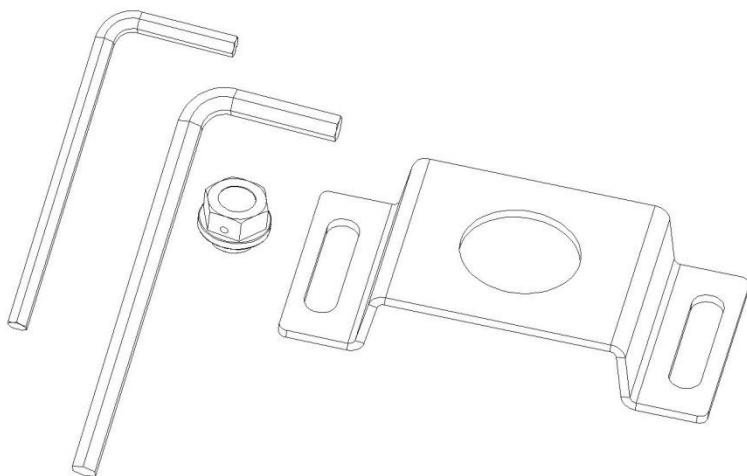

Details:

- 1、 one 4# allen key
- 2、 one 5# allen key
- 3、 One feeding panle with one hole
- 4、 Plastic nut for exhaust of reducer

Operation Instruction

1. Select the appropriate feeding hole according to the wire diameter.

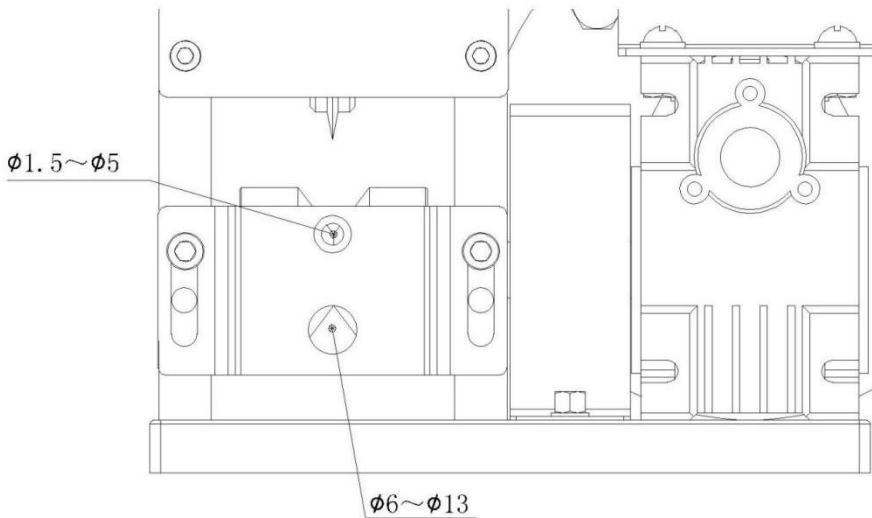

When the diameter of the wires to be treated does not exceed 13mm, select the two hole incoming board

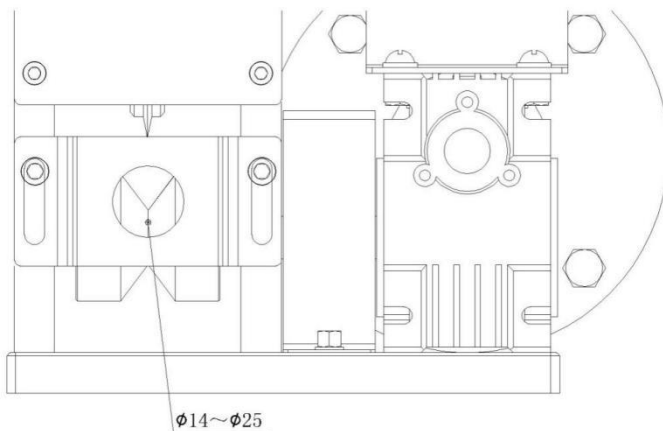

When the diameter of the wires to be treated exceeds 13mm, select the one hole incoming board

2. During wire stripping, the center of the blade must be collinear with the center of the rolling gear (as shown below)

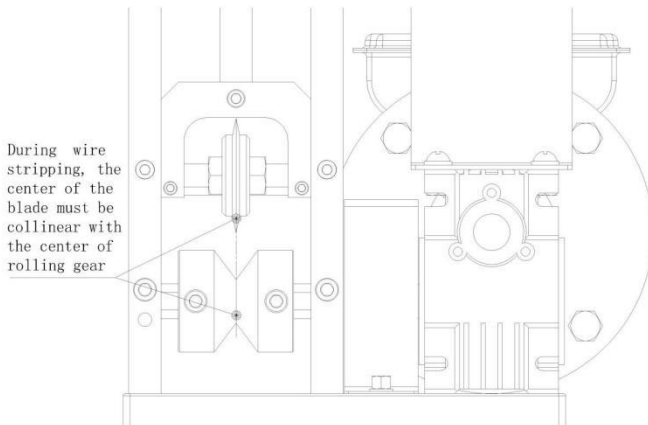

3. Adjust the height of the blade, and it is best to make the blade scratch the wire skin without damaging the copper core by rotating the plastic handle screw (clockwise rotation is downward and counterclockwise rotation is upward), as shown below.

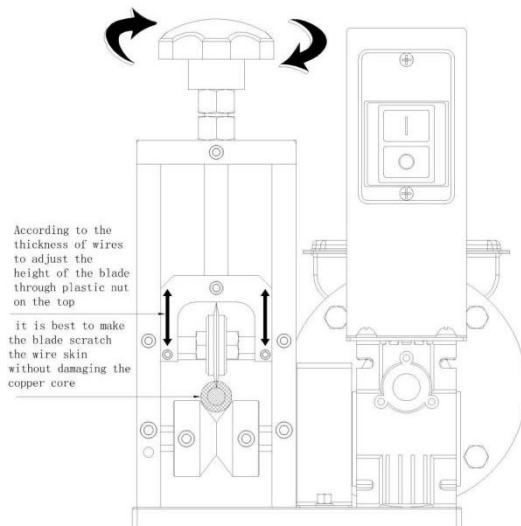

4. When stripping, adjust the height of the feeding plate according to the thickness and hardness of the wire (generally, the feeding panel should be adjusted for thick wire and hard wire and lower for soft wire and thin wire). In this way, the wire is not easy to be eccentric when stripping

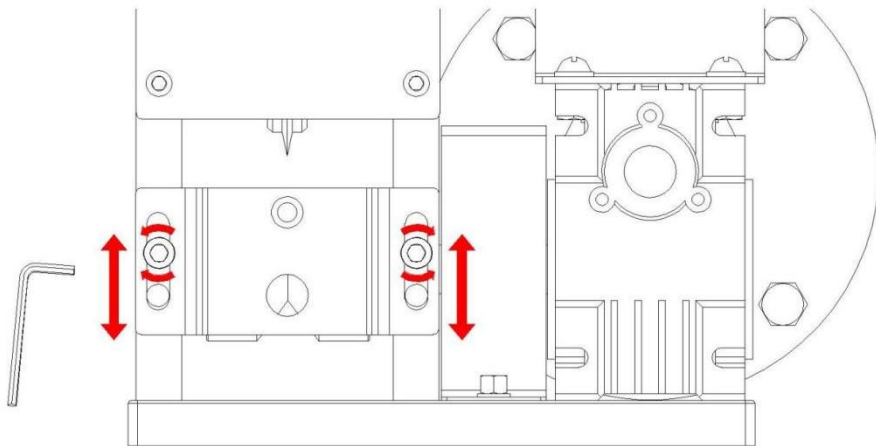

5. When the diameter of the wire to be treated does not exceed 20mm, the two rolling gears need not be separated

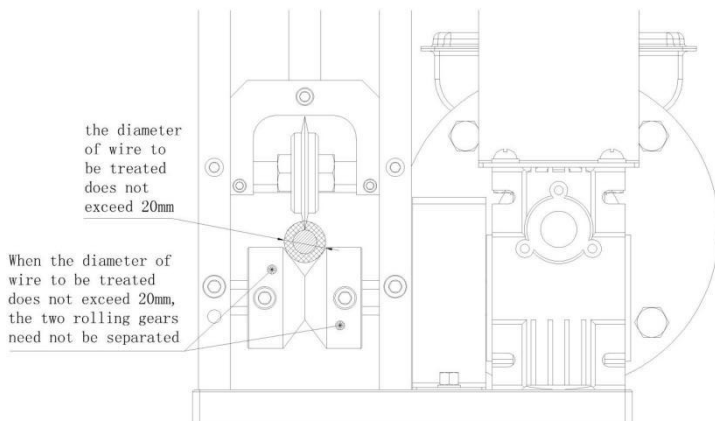

When the diameter of the wire to be treated exceeds 20mm, the two rolling gears need to be separated by loosening the two screws in the gears.

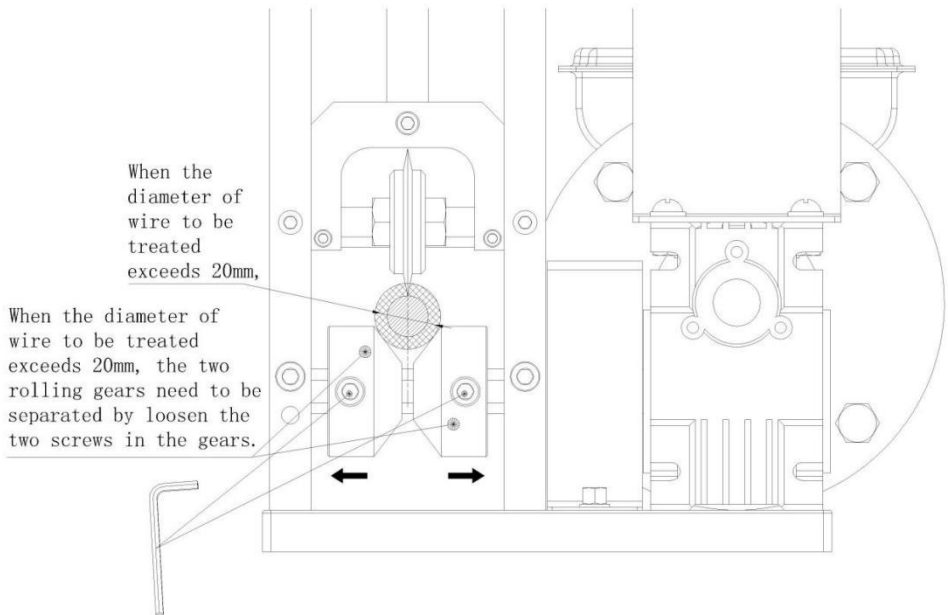

6. If the machine cannot strip the wire, there may be several reasons:

- ① The diameter of the stripped wire is too small (the diameter of the wire to be treated, including the outer skin, shall not be less than 1.5mm)
- ② The center of the blade is not on the same line as the center of the rolling gear
- ③ The blade is not sharp

NOTE: Never put your hand in when the machine is running (you must stop the machine before checking, debugging, and troubleshooting the machine). To avoid cutting your hand, do not touch the blade directly with your hand.

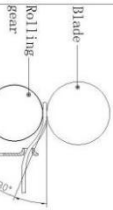
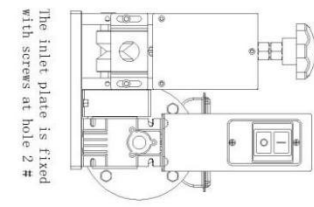
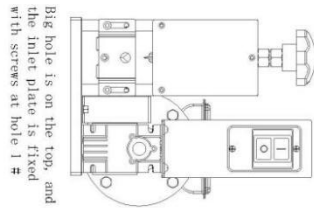
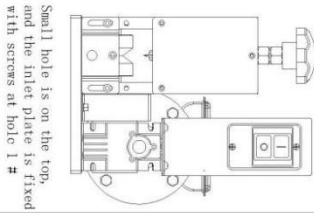
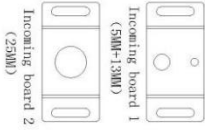
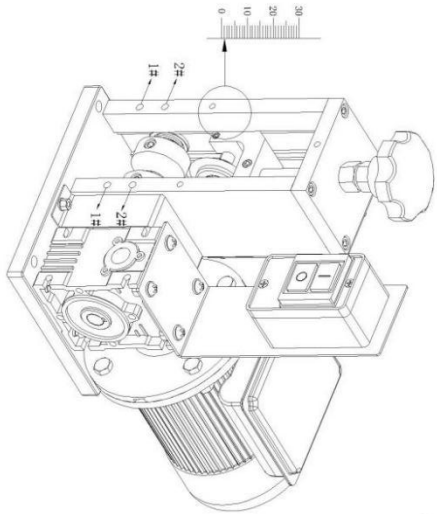

Figure 1

Incoming board 1
There is an obvious angle between the inlet hole and the tangent line

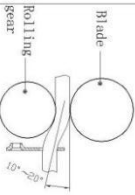

Figure 2

Incoming board 1
The concave side faces the blade (there is a concave side at the small hole) There is an obvious angle between the inlet hole and the tangent line

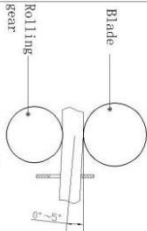

Figure 3

Incoming board 2
The concave side faces the blade, and the inlet hole is basically aligned with the tangent line or slightly lower

Environmental Protection

This product is subject to the provision of European Directive 2012/19/EC. The symbol showing a wheelie bin crossed through indicates that the product requires separate refuse collection in the European Union. This applies to the product and all accessories marked with this symbol. Products marked with this symbol cannot be discarded with normal household waste but must be taken to an electrical and electronic equipment collection point for recycling.



Manufacturer:

Taizhou Senduo Environmental Protection Equipment Technology Co.,
Ltd.

Address:

Workshop B14, Xiaowufen Industrial zone, Luqiao Town, Taizhou
City, Zhejiang, China

Importer: WAITCHX

Address: 250 bis boulevard Saint-Germain 75007 Paris

Importer: FREE MOOD LTD

Address: 2 Holywell Lane, London, England, EC2A 3ET



EUREP UK LTD
UNIT 2264, 100 OCK STREET, ABINGDON
OXFORDSHIRE ENGLAND OX14 5DH



EUREP GmbH
Unterlettenweg 1a, 85051
Ingolstadt, Germany

VEVOR[®]

TOUGH TOOLS, HALF PRICE

Support and E-Warranty Certificate <https://www.vevor.com/support>