

S W T Series Full-automatic Computer Wire Stripping Machine

Operation Manual

M O D E L : C、SD、SDB、SDB2、E、JE、JE2、HT2、
BHT2、NX2、MAX1-4、MAX1-6、MAX1-8

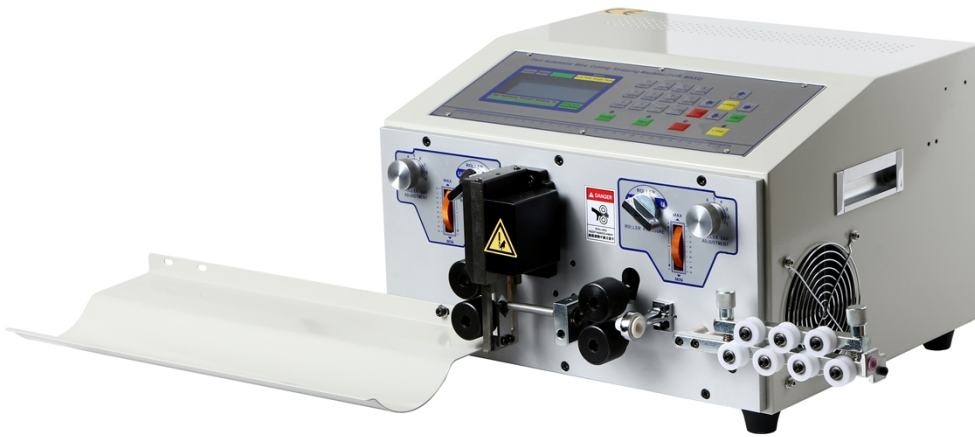

Scope of Application

SWT Series Full-automatic Computer Wire Stripping Machine made by our factory is suitable for cutting, head-stripping, tail-stripping and middle-stripping of single –strand, multi-strand and sheathed wire. The maximum processing cross-sectional area is 0.1-50mm²; the maximum cutting length is 100m, head-stripping 200mm and tail-stripping 100mm. SWT508-NX2 is suitable for stripping and twisting super short and thin wires with shortest wire of 28-30mm; With rollers lifting function during stripping, SWT508-HT2 is suitable for stripping sheathed wire especially for sheath wire of long Wire Head and Wire Tail. SWT MAX2 is the best option to process super thick cable wire of cross-sectional area 35-50mm².

Weight: 32KGS

Overall Dimensions:

Power: 350W

Mode of Display: LCD Liquid Crystal Display Screen in English and Chinese

Cutting Length: 0.1mm-100m

Cutting Tolerance: $\leq 0.002 \times L$ (L = Cutting Length)

Cutting Cross-sectional Area of Wire Core:

Maximum Diameter of Conduit Pipe:

Middle-stripping: 12 places of stripping

Knife Material: High-quality Tungsten Steel

Stripping Speed:

Mode of Driving: 4-wheeled Drive (Silent hybrid stepping motor, each step 0.1mm forward)

Adjusting Speed: 0 Slowest, 9 Fastest

Points for Attention of Safe Operation

First of all, thank you very much for buying our SWT Series Full-automatic Computer Wire Stripping Machine. For safe and correct operation of this machine, please read this operation manual carefully before operation.

I . Power Adapter: AC 220–250V, 50–60HZ. In order to provide a stable operating voltage, the user should select and use power voltage stabilizer so as to prevent this machine from being burned out caused by over-voltage.

II . On operation this machine should be placed on a smooth and stable surface so as to prevent this machine from falling down and being damaged.

III. Don't use this machine near an area with stronger electromagnetic field so as to prevent this machine from being interfered.

IV. On operation don't place any objects on this machine, don't place this machine near corrosive chemicals, be sure to keep the operating environment dry, well ventilated and dustless, operating room temperature: 0–35°C.

V . On operation if bad effects of wire stripping or some faults appear, please read this operation manual for faults and clearances, if you still cannot solve the problems, please call our technical service telephone to realize the method of maintenance and repair. For your safety, please don't disassemble this machine by yourself for maintenance and repair.

Note: According to the stipulations in the relevant laws and regulations of the People's

Republic of China, the power of interpretation for the relevant contents in this Operation

Manual belongs to our factory. The contents are subject to change without notice.

The

Edition No. of Operation Manual: V3.0

Main Structure of Wire Stripping Machine

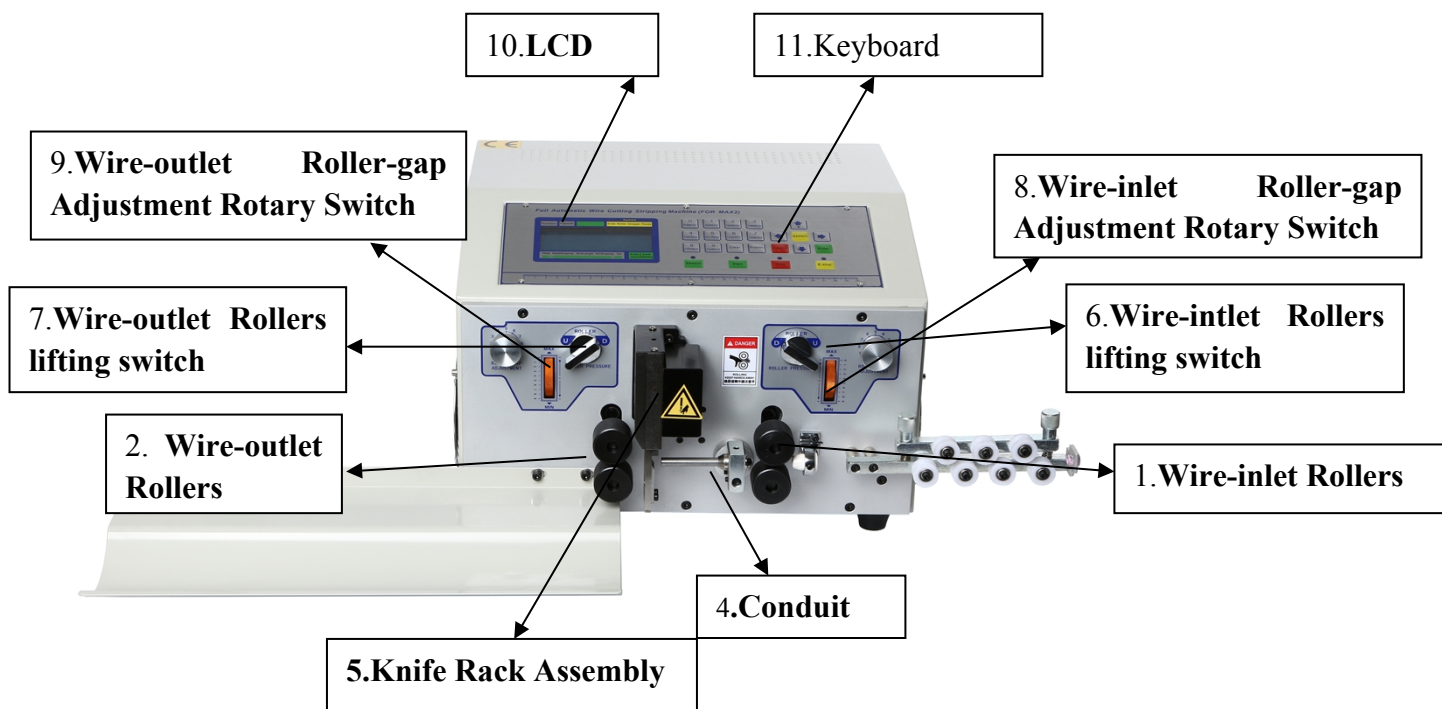

(Table1-1)

Note: You need to add oils to the oiling hole at the top of the knife rack regularly so as to keep it well lubricated.

(See Table 1-1) Explanation of the main structure:

1. Wire-inlet Rollers: Assist the knife rack to perform wire head stripping when it moves forward or back forward the wire.
2. Wire-outlet Rollers: Assist the knife rack to perform wire tail stripping, wire twisting and wire output.
3. Wire-inlet: Wire is put into the machine through the inlet.
4. Conduit: Wire goes through the conduit while feeding in.
5. Knife Rack Assembly: For wire cutting: head stripping and tail

stripping.

Wire-inlet Rollers lifting switch: Press the switch button to lift the inlet rollers and let the wire be feeding in to knife cut-off position; Press the button again to put down the rollers and press to the wire . The tightness of the pressing can be adjusted by the roller gap.(Note: Normally during stripping , it is needed to press the lifting button again as the wire will be needed to pressed down. If the tightness between the roller and wire is not enough, you may need to adjust the roller gap till it works.)

6. Wire-outlet Rollers lifting switch: Press the button to lift the out-let rollers and press again to put down the rollers and press to the wire.The tightness of the pressing can be adjusted by the roller gap.

7. Wire-inlet Roller-gap Adjustment Rotary Switch: Turn the switch with larger digits to increase the gap and vice versa. (Note: the rotary switch should be adjusted after air cylinder lifting roller because of the air cylinder pulling power.

8. Wire-outlet Roller-gap Adjustment Rotary Switch: Turn the switch with larger digits to increase the gap and vice versa.

10. Liquid Crystal Display(LCD): Display wire stripping related parameter.

11. Keyboard: Input parameter, start and stop the machine.

12.Air filter

Fast operation example

1.Strip and cut 35mm² copper wire of 7 strands, total length 150mm, head stripping 20mm, tail stripping 20mm: set up as follows:

Speed						
Function	Program number		Knife	Roller	Stripper	Pause
Long Wire	0	C C 5 5	5	7	3	3.0
S. TOT: 50000			TOT: 0			
S. BUN: 500			BUN: 0			
20.0	30.0	150.0	30.0	20.0	480	80
Head Head Stripping Wire Length Tail Stripping Tail					Knife Value	Knife Retreating

2. Strip and cut 50 mm² copper wire of 19 strands, total length 150mm, head stripping 20mm, tail stripping 20mm, change the parameter in above picture: knife value from 435 to 500; knife retreat from 85 to 90.

The above parameters are for reference only and specific set-up will still depend on processing wire.

Note: The small of the knife value is , the deeper of the cutting is; the thicker of the wire is, the larger of the knife retreat value should be. The following table is the reference parameter data for the set-up of knife value and knife retreat value:

Operating instructions

Drawing of control panel

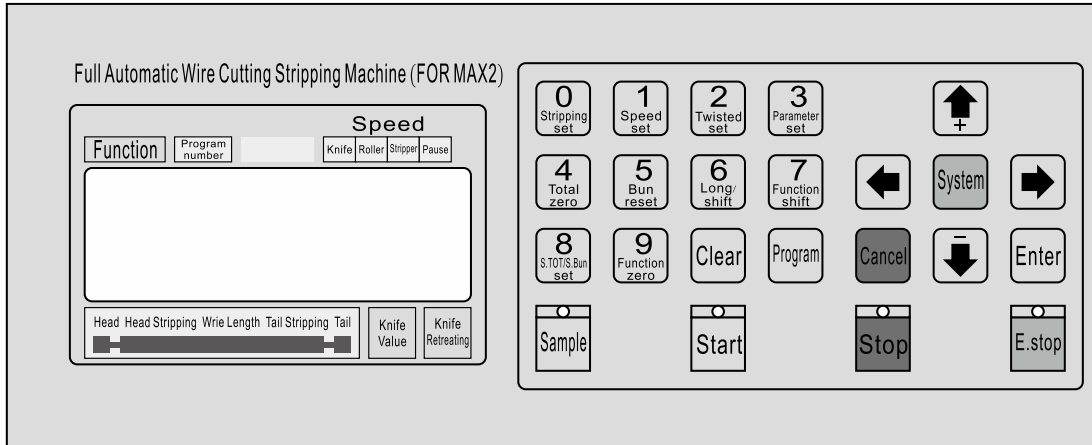

The system interface is composed of 23 keys and a 192×64 dot matrix LCD display, the following will be introduced to each key function

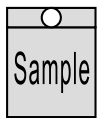

: In the standby mode, each short press once, machine performs a single-step, cyclic; even following the press more than about 0.5 seconds, the machine will automatically run a loop; the button in the machine control effect is very big;

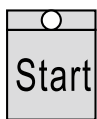

: In the standby mode, press this button, the machine begins to work;

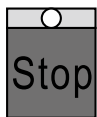

: In the working statue, press this button, the machine will finish the work after shutdown;

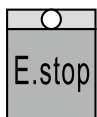

: In the standby mode, press this button, the machine will perform

a reset action; in the working state, press this button, the machine to shut down, after the implementation of the reset action;



: In a data input state press this key, enter the number 0; in the standby state press this button, the machine will enter the stripping parameter setup state;



: In a data input state press this key, enter the number 1; in the standby state press this button, the machine will enter the speed parameter setup state;



: In a data input state press this key, enter the number 2; in the standby state press this button, the machine will enter the twisting parameter setup state;



: In a data input state press this key, enter the number 3; in the standby state press this button, the machine will according to the current function into setting picture corresponding to the function;



: In a data input state press this key, enter the number 4; in the standby state press this button, volume 0;



: In a data input state press this key, enter the number 5; in the

standby state press this key, the count of 0;



: In a data input state press this key, enter the number 6; in the standby state press this button, switch machine working mode;



: In a data input state press this key, enter the number 7; in the standby state press this button, switch machine working mode;



: In a data input state press this key, enter the number 8; in the standby state press this button, the machine will enter the output settings;



: In a data input state press this key, enter the number 9; in the standby state press this button, the machine will enter the function setting picture;



: In a data input state press this key, removal of the input data; in the standby state press this key, total output and the number of full clear 0;



: In the standby state press this button, the machine will enter the program settings;



: In the parameter settings by pressing the key, set parameters most low plus 1; in a parameter setting state press this button, the knife value plus 1;



: In the parameter settings by pressing the key, set parameters most low plus 1; in a parameter setting state press this button, the knife value minus 1;



: In the parameter settings by pressing the key, the modified data to give up, the last data into modified object;



: In the parameter settings by pressing the key, the modified data to give up, the next data into modified object;



: In the parameter set state press this key, the modified data will be saved and written to the EEPROM, and the next data into modified object;



: In the parameter set state press this key, exit parameter setup state; the function setting screen, segmental stripping setting screen, system setup screen. Press this key, return to work picture;



: On the standby screen, press the key, enter the system arrangement of the picture, need to enter the password before entering, in a setting screen, function; multistage peeling setting picture picture, system settings, you press the key, enter the parameter setup state;

Work screen

Once the machine is powered on, the screen display boot screen, about three seconds will display this picture; the machine begins to run, in the picture on the screen; otherwise, the machine could not start;

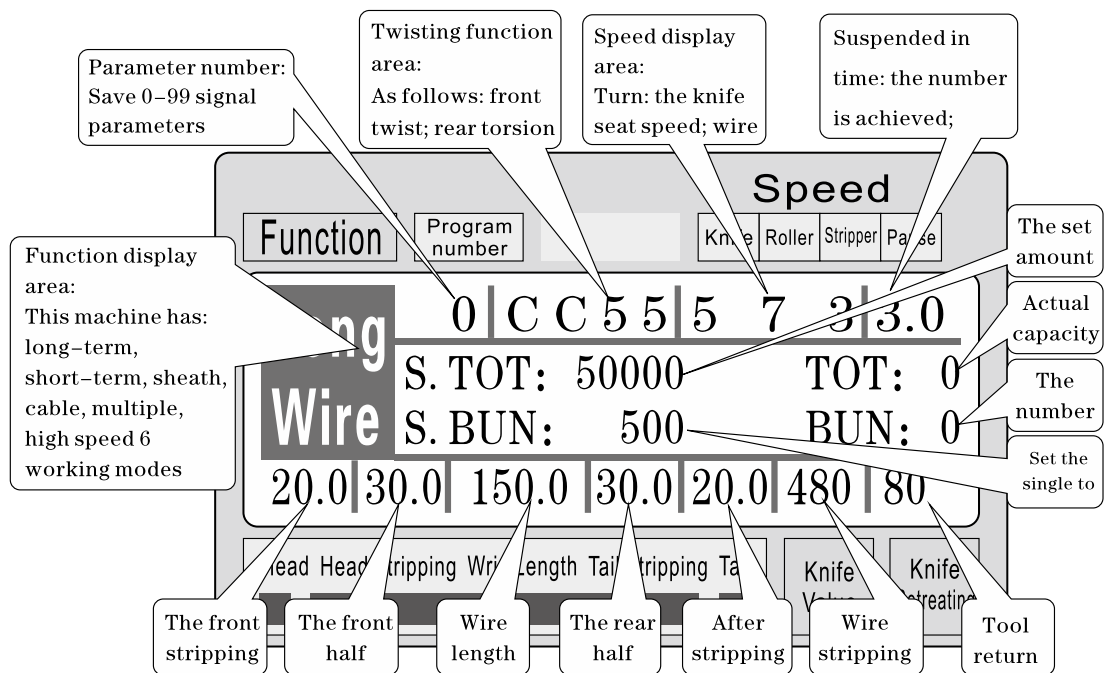

Stripping parameter setting: The machine when in standby mode, press



; front length parameter begin to flicker, at this time can directly

enter the number, if the input error, press



clear input digital input

again; then press



preservation, and a parameter flicker, until the

front end length, front half stripping, total length, rear half stripping end

length, cutter, knife back all the input completion value; **The small of the**

knife value is , the deeper of the cutting is; the thicker of the wire is,

0the larger of the knife retreat value should be; Parameter setting press



flashes forward a parameter; press



after the removal of a

blinking parameters; at any time by



withdraw from the set of parameters, back to the standby state;

Stripping speed settings: The machine when in standby mode press



; cutter speed parameter started flashing at this time can directly

enter the number, if the input error, press



clear input digital input

again; Then press



preservation, and a parameter flicker, until the

cutting speed, feeding speed, stripping speed, pause time all input to

complete; Parameter setting; press



flashes forward a parameter;

press



after the removal of a blinking parameters; at any time by



withdraw from the set of parameters, back to the standby state;

Output settings:

The machine when in standby mode press



; gross

parameter set to begin to flicker, at this time can directly enter the number,



if the input error, press





clear input digital input again; Then press







preservation, and a parameter flicker, until the set, the total

number of all input to complete; Parameter setting; press  flashes forward a parameter; press  after the removal of a blinking parameters; at any time by  withdraw from the set of parameters, back to the standby state;



Twisted line set: The machine when in standby mode press  ;

Front twist mode scintillation, this time press  ,  switching,

Then press  preservation, and a parameter flicker, until the front twist, twist wire mode input mode is completed, then by previous methods input torsion line speed, twisting strength; Parameter setting;

press  flashes forward a parameter; press  after the removal of a blinking parameters; at any time by  withdraw from the set of parameters, back to the standby state;

Program number set: The machine when in standby mode, press  ;

program arguments begin to flicker, at this time can directly enter the number, if the input error, press  clear input digital input again; then press  preservation, to standby state;

Work mode switch: The machine when in standby mode, press



work mode switch;

Work mode explain

This machine is a multifunctional wire cutting machine, a total of 6 kinds of wire cutting & stripping procedure, following picture description:

Line mode:

Speed						
Function	Program number		Knife	Roller	Stripper	Pause
Long Wire	0	C C 5 5	5	7	3	3.0
	S. TOT: 50000			TOT: 0		
	S. BUN: 500			BUN: 0		
20.0	30.0	150.0	30.0	20.0	480	80
Head Stripping Wrie Length Tail Stripping Tail				Knife Value	Knife Retreating	

The model and the traditional 220 wire cutting machine function, can be mounted wire twisting device to increase the twisted wire, wire length as shown, only according to the above method to input a desired

size, at this mode  function is not available;

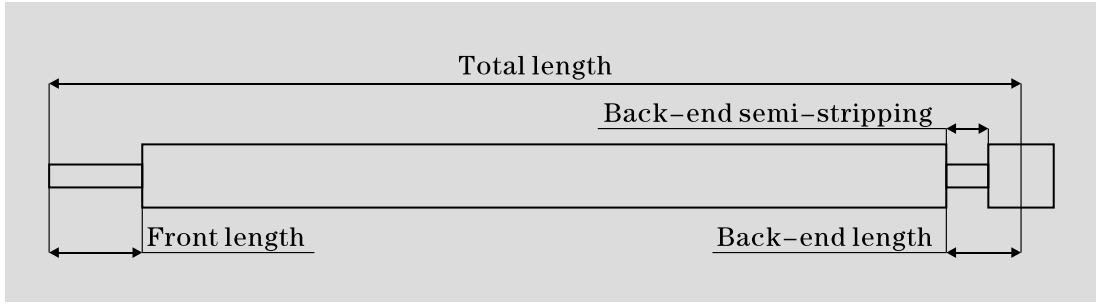

The short-term model:

Function		Program number		Speed					
				Knife	Roller	Stripper	Pause		
SHOR	0	C	C	5	5	5	7	3	3.0
Wire	S. TOT: 50000			TOT: 0					
	S. BUN: 500			BUN: 0					
20.0	30.0	150.0	30.0	20.0	480	80			
Head Head Stripping Wrie Length Tail Stripping Tail				Knife Value		Knife Retreating			

The model machine and long-term is basically the same, only the machine stripping action is not the same; and no twisting line function; at

this mode 3
Parameter set function is not available;

Speed

Function Program number Knife Roller Stripper Pause

MULT SECT A	0 C C 5 5 5 7 3 3.0
S. TOT:	50000 TOT: 0
S. BUN:	500 BUN: 0
10.0 0.0	235.0 0.0 5.0 540 40

Head Head Stripping Wrie Length Tail Stripping Tail Knife Value Knife Retreating

Front length

The front half

The total length of wire, no need to set up the program will automatically end

The rear half

Rear length, no need to set up, the program will automatically will last the peeling length as a back end length

This mode without twisting line function; press 3 Parameter set Function into the following cable function setting picture:

Multisection Setting

1# Length:	10.0		Strip:	5.0
2# Length:	10.0		Strip:	5.0
3# Length:	10.0		Strip:	5.0

Head Head Stripping Wrie Length Tail Stripping Tail Knife Value Knife Retreating

The first section of the total length: the length of the back rubber, examples are illustrated

The first section of stripping length: peel rubber part length, behind



In a parameter setting condition, press ↑
+ , ↓
- upward or

downward view 1-12 segment set parameters; press  set parameter,
Until all parameters input to complete;

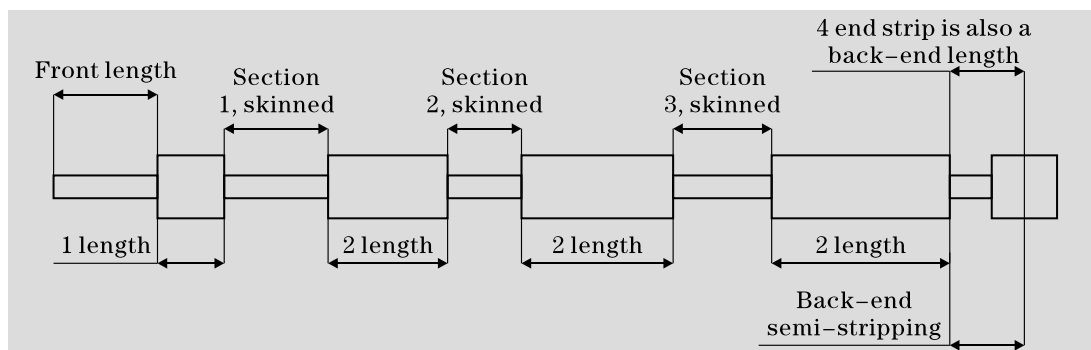
Note: in a multistage model, total is equal to the length of each wire length and coupled with the front end length, procedures have been calculated automatically and highlight, so set the total length, the length of the whole no end; end length is the final end of the length of! Also no need to set up, when the required length is arranged is completed, a set of 0



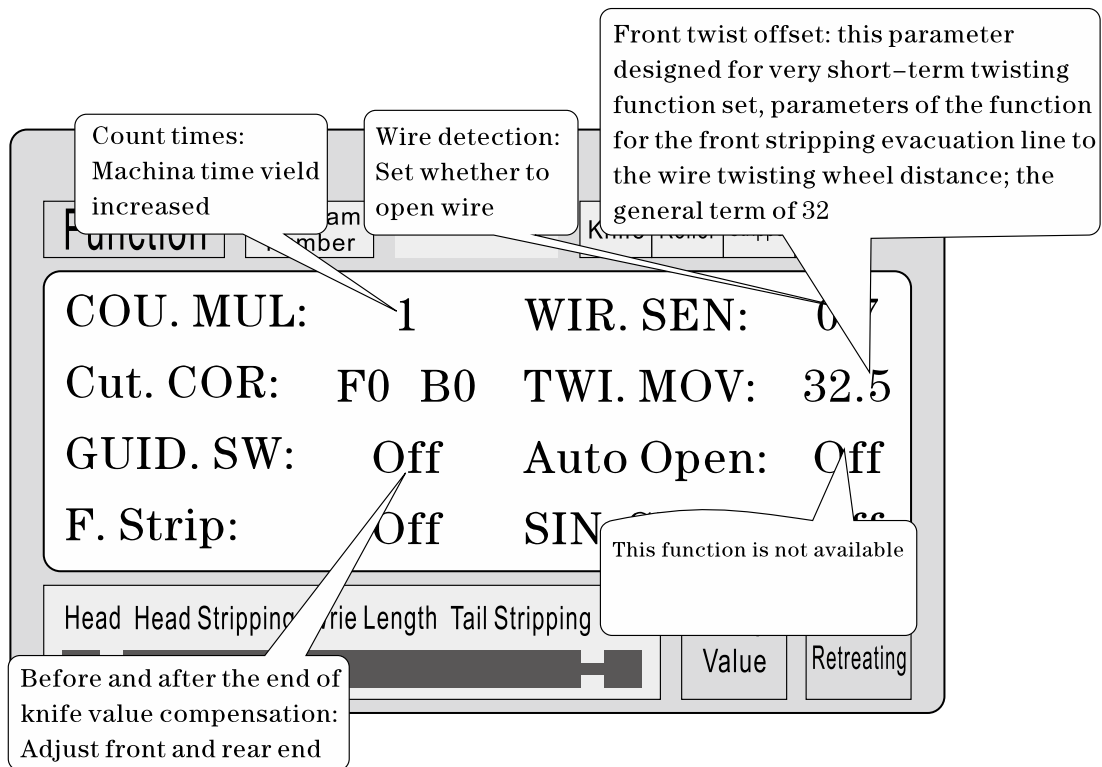

Function setting picture

In the standby state, press  to enter this screen; in the picture display, the machina does not start the work, press  return to work picture;



Parameter setting: press  start settings, until all parameters input to complete;

System setup screen: Standby state, press  to enter this screen; input password (10010011) to enter this screen; display the picture, the

machine does not start the work, press  return to work picture;

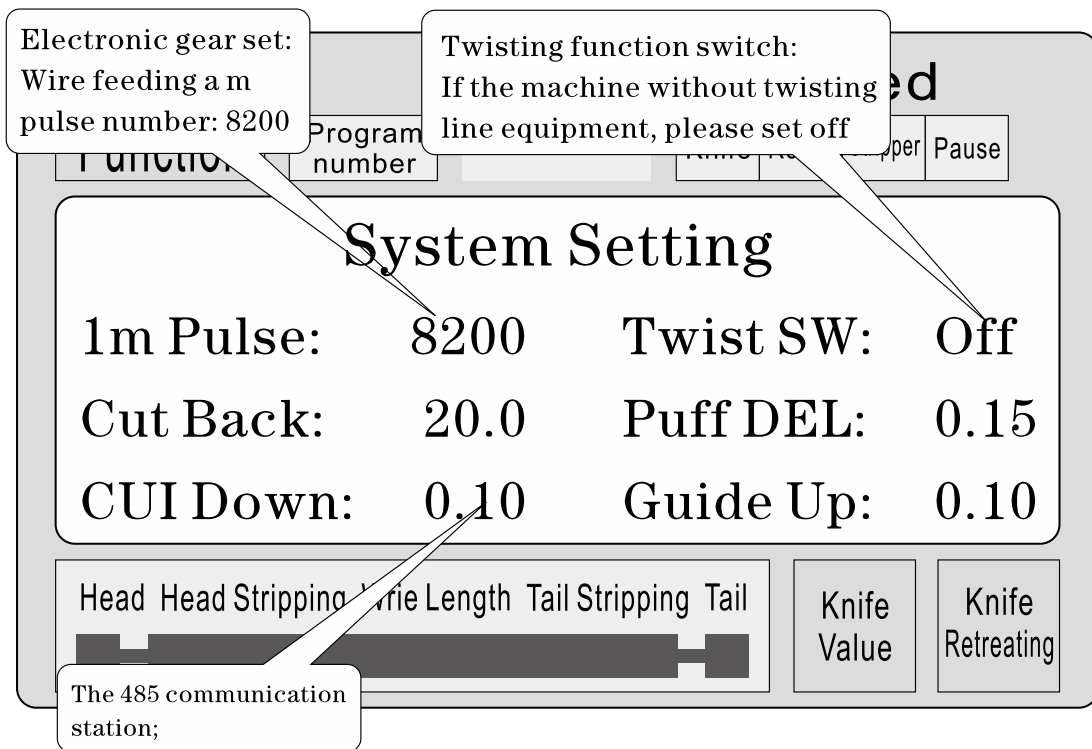

Parameter setting: press  start settings, until all parameters input to complete;

Stripping set matters needing attention

- 1、 a number of stripping parameter, total length must be greater than the front end length + back-end length; otherwise the work machine;
- 2、 the use of communication control of the machine, must ensure that the machine in the display screen work and non parameter setup state; otherwise, the communication control is invalid;
- 3、 use the appropriate speed operation;
- 4、 in the screen work and non parameter settings, Can be directly press



the cutter set value without stopping;

- 5、if the four running indicator light flashes, illustrates the setting parameters, can start the machine;
- 6、twisting line setting: the first torsional offset parameters is designed for short-term twisting function set, meaning when the machine off your front, wire feeding after twisting wheel distance; sometimes can be fitted to the short-term blade after twisting wheel, then the parameter set small, reach short-term torsion a line function; general line is set to 32, no need to change; short-term according to the blade and the wire twisting wheel actual distance adjustment; (can single-step operation mode to the step, if the wire feeding more than wire twisting wheel, can reduce the parameter can be increased, and vice versa;)

Six, Introduction of communication protocol

The machine is equipped with a standard RS485 communication function, the user can through the host computer (PLC, PC) to directly control the machine; communication hardware specifications for 38400, 8, 1, N

The following is the machine accepts commands in detail

- 1、the emergency stop command: PC issued three byte hexadecimal number 16 01, 66, 99; wherein the first 01 is the station number, can

set up a system screen to change, the machine successfully received the order will return received the three bytes of data, this machine has received notice of the command;

2、 stop command: PC issued three byte hexadecimal number 16 01, 77, 88; wherein the first 01 is the station number, can set up a system screen to change, the machine successfully received the order will return received the three bytes of data, this machine has received notice of the command;

3、 stop command: PC issued three byte hexadecimal number 16 01, 88, 77; wherein the first 01 is the station number, can set up a system screen to change, the machine successfully received the order will return received the three bytes of data, this machine has received notice of the command;





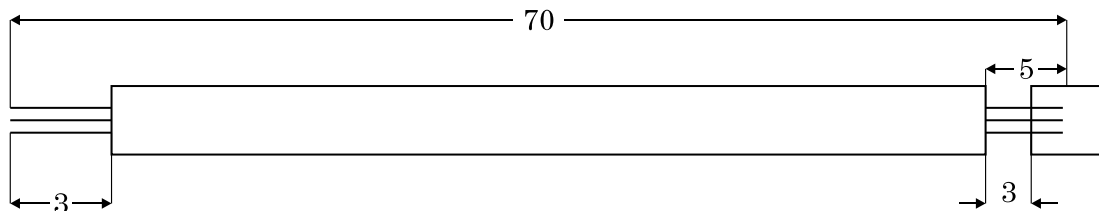



Seven, Wire cutting example

(1) long pattern



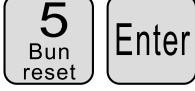

1、 The wire is placed in a roller intermediate, adjust the rool gap to have just come into contact with the wire and then down 2 big;

2、 Set size:

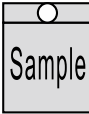
- (1) Enter setup mode: Standby mode press 
- (2) Set the front stripping length 
- (3) Set the first half stripping length 
- (4) Total length 
- (5) Set the last half stripping length 
- (6) Set back length 
- (7) The cutter set value: (Reference) 
- (8) Set back the knife: (Reference) 
- (9) Set line mode: press  Set line mode;

3、press  more than 0.5 seconds, the machine will stop automatically after carrying a line, have a look whether the value of the

right knife, directpress  、  correction; Until satisfied;

(2) Multi segment peeling

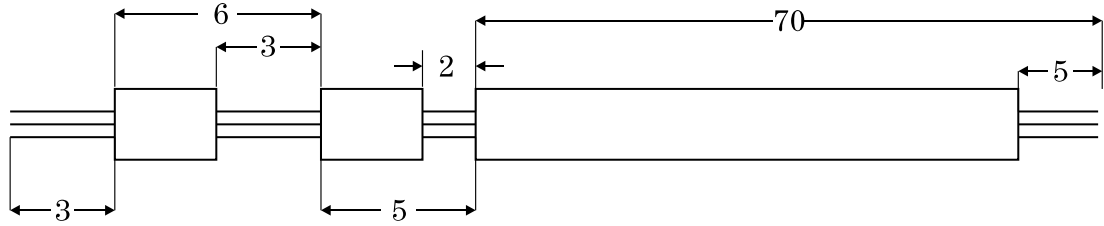

1、 the wire is placed in a roller intermediate, adjust the roll gap to have just come into contact with the wire and then down 2 big;

2、 setting size:

- (1) Enter setup mode: Standby mode press 0
Stripping
set
- (2) Set the front stripping length 3
Parameter
set Enter
- (3) Exit strip, parameter setting 0
Stripping
set Enter
- (4) Set multistage mode: press 7
Function
shift set to multi
segment model;
- (5) Enter the number of segments is set: press 3
Parameter
set set to more
footage;
- (6) Set the first segment length of stay skin System 3
Parameter
set Enter
- (7) Set the first segment peeling 3
Parameter
set Enter
- (8) Set second leaving skin length 3
Parameter
set Enter
- (9) Set second 2
Twisted
set Enter

(10) Set third leaving skin length



(11) Set third leaving skin length

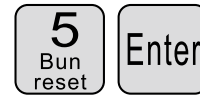



(12) Set fourth as the length



(13) Return to work picture

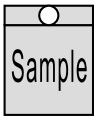

(14) pree  more than 0.5 seconds, the machine will stop automatically after carrying a line, have a look whether the value of the

right knife, directpress  ,  correction; Until satisfied;

Explain

- 1、 if the third set to 0, then the program that you just cut in two, and so on; if you want to peel the 12section, the 12section of the length of the whole set;
- 2、 multiple stripping mode, twisting line function is invalid;

The adjustment o knife cutting position

1. Start the machine.
2. Adjustment of MAX2 knife position: the distance between two knife blades' noses should be around 8-10mm while the distance between two blades' V shape bottom points should be around 34mm.(See Picture A)
3. Key points of attention for changing knife blades:
 - 1.The up plane of inner left knife rack should be blow right knife rack plane with 19mm which also should be lower than knife rack outside frame with 4mm as shown by picture B.
 - 2.Left gear should be higher than middle gear with 1 gear height while the right gear should be higher than middle gear with 6 gear heights.(See picture B)
 3. Normally, the distance between two knife blades' noses should be around 8-10mm while the distance between two blades' V shape bottom points should be around 34mm.(See picture A)
 4. After adjustment, insert both sides of knife rack gears into middle axil tooth and fix the screws of both sides knife rack.

Eight, Phenomenon and exclusion

The emergence of the phenomenon	Processing method
Thread stripping without	<ol style="list-style-type: none"> 1、 check the thread cutting depth, cutting marks too shallow for regulating “ diameter ” smaller. 2、 the line wheel pressure is not enough, need to adjust the “ into the line wheel pressure regulating knob ”, the line wheel pressure. 3、 the line wheel clearance is too large, need to adjust the “ into the line wheel clearance adjustment knob ”, the line wheel clearnce is reduced to a proper position. 4、 stripping the first set is greater than or equal to 3. 5、 the line wheel if there is dirt, required to be cleaned. 6、 retreat knife set may be too large, should be appropriate to reduce the retracting parameter (reference value 00-10). 7、 the next tool misalignment, please refer to chapter seventh section 2 test chart 7-7 alignment condition.
Wire stripping without tail	<ol style="list-style-type: none"> 1、 check line tail cutting depth, cutting marks too shallow for regulating “ diameter ” smaller. 2、 wire wheel, the pressure is not enough, need to adjust the “ round round pressure regulating knob ”, the line wheel pressure. 3、 wire wheel clearance is too large, is required for the regulation of “ round round gap adjustment knob ”, make the pulley gap is reduced to a proper position. 4、 stripping the first set is greater than or equal to 3. 5、 pulley if there is dirt, required to be cleaned. 6、 retreat knife set may be too large, should be appropriate to reduce the retracting parameter (reference value 00-10). 7、 the next tool misalignment, please refer to chapter seventh section 2 test chart 7-7 alignment condition.
Wire skin of severe barotrauma	<ol style="list-style-type: none"> 1、 first judge barotrauma from inlet wheel or pulley, wheel pressing force to be small. 2、 contact with my company, the purchase of rubber tire.
Thrum peel line core cut of several root	The “ diameter ” tone in 1 or 2, retry until notto hurt the line core.
Length of line, there is greater than or equal to the set length	<ol style="list-style-type: none"> 1、 the line wheel pressure is not enough, and sometimes thread stripping without phenomenon, thread stripping on line is greater than a predetermined length, regulating “ into the line wheel pressure regulating knio ”, so the line wheel pressure. 2、 dirt, pulley, required to be cleaned. <p>A wire inlet wheel clearance is too large, to adjust the “ into the line wheel clearance adjustment knob ”, and a wire feeding wheel gap smaller.</p>

Length of line, there is less than or equal to the set length	<ol style="list-style-type: none"> 1、 the wire itself line thickness a. 2、 a rolling wheel with dirt, required to be cleaned. The conductor surface wax, lead into, wire wheels slip with sticky wax, wire brush, and gasoline cleaning four rolling wheel. 3、 take out wire, level “ 00 ” air operation phenomenon, be excluded. 4、 the wire laying frame having card hysteresis phenomenon, leading to poor conveying wire.
Head and tail cut or no cut	<ol style="list-style-type: none"> 1、 check the head or tail of sevred, wire diameter is too small, should adjust the “ wire ” bigger. (a reference value 30-90) 2、 Checking thread tail no cut marks, wire diameter is too lare, should adjust the “ wire ” smaller. (a reference value 30-90)
Sometimes the head or tail was cut off	<ol style="list-style-type: none"> 1、 wire wheel, the pressure is not enough, please check and regulation of “ round round pressure regulating knob ”, make the pulley pressure becomes great. 2、 the line wheel clearance is too large, need to adjust the “ into the line wheel clearance adjustment knob ”, the line wheel clearance reduction.
There are several strands of wire long thread	<ol style="list-style-type: none"> 1、 wire diameter is too small, the cut wire, strip with a copper wire, to increase the diameter of 1-2, try again. 2、 retreat knife set too small, it should be increased the retracting parameters (00-10)
Sometimes the conducting wires together no knife broken	<ol style="list-style-type: none"> 1、 the edge parts activities with the ordinary oil, try again (usually 8 hours filling a). 2、 the speed is slow. 3、 check the wire specifications in AWG12# line (3 square). 4、 the blade is blunt, flat grinding, or replacement. 5、 according to the seventh part of the third inspection.
Press run after shutdown can only cut a, screen appears “ short line or knot ”	<ol style="list-style-type: none"> 1、 no line of automatic shutdown function, belongs to the normal. 2、 setting the length should be greater than 32 mm (except for the 98 procedures). 3、 wire wheel clearance is too large, is required for the regulation of “ round round gap adjustment knob ” make the pulley reduced gap.
When the power is switched on the fan to work normally, screen normal, but according to “ run ” after the machine can not move	<ol style="list-style-type: none"> 1、 because of the voltage instability or illegal operation of the circuit board in the insurance pipe burn, need to replace the fuse (open the case cover, visible in the circuit board has two 5A insurance tube). 2、 such as changing insurance tube, continue to burn out, and my company customer service service department or office contact.
Incision inclined tangent	<ol style="list-style-type: none"> 1、 wire itself is too curved, the purchase of a straightening device. 2、 a lead mouth without facing edge center. 3、 a tail tilts, inspect the wire pipe is leaning against the tool too close.