

MICROSCOPE STAND INSTRUCTIONS

ZQ-1

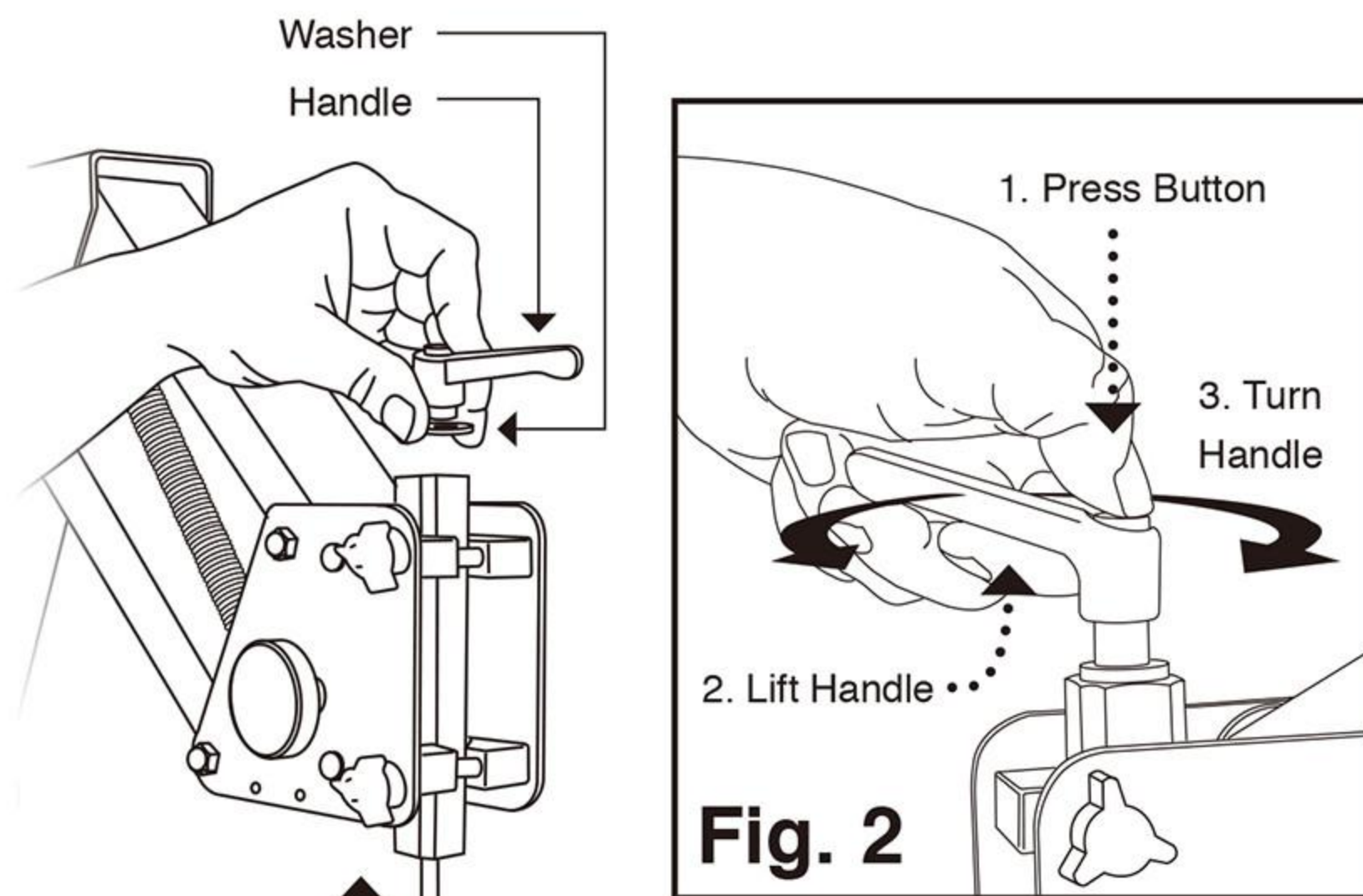

MICROSCOPE STAND INSTRUCTIONS



Install Ring / Bracket Assembly

- (Fig. 1) Insert the rod into the bottom of the mounting post, then attach handle.
- Make sure the washer is under handle.
- Position handle **away** from stand arm by lifting the handle while pressing the center button (Fig. 2). This does not loosen the handle.

To attach the stand to your work bench, see Microscope Stand Base Template (page 3).

The microscope body sets into the ring and is secured by three thumb screws, included.

Install Headrest

After installing the microscope, attach the headrest (Fig. 3). Make sure white nylon washer is between the T-Knob and the headrest mount. Adjust the angle using the side T-Knob; adjust depth using the top T-Knob. The forehead end may also be adjusted.

Setup and Operation

After the stand is secured to the bench top there are many choices for adjustments to fit your needs. Turn tension knobs clockwise to add friction, counter-clockwise to reduce friction.

- A. Controls front arm. *Tension knob.*
- B. Controls friction during movement of back arm. *Tension knob.*
- C. Controls angle of microscope on pivot ball. Loosen to adjust.
- D. Adjusts focus. *Tension knob.*
- E. Locks arm height on the stand rod.
- F. Controls the drag of the arm swing.
- G. Tighten for additional arm rigidity.

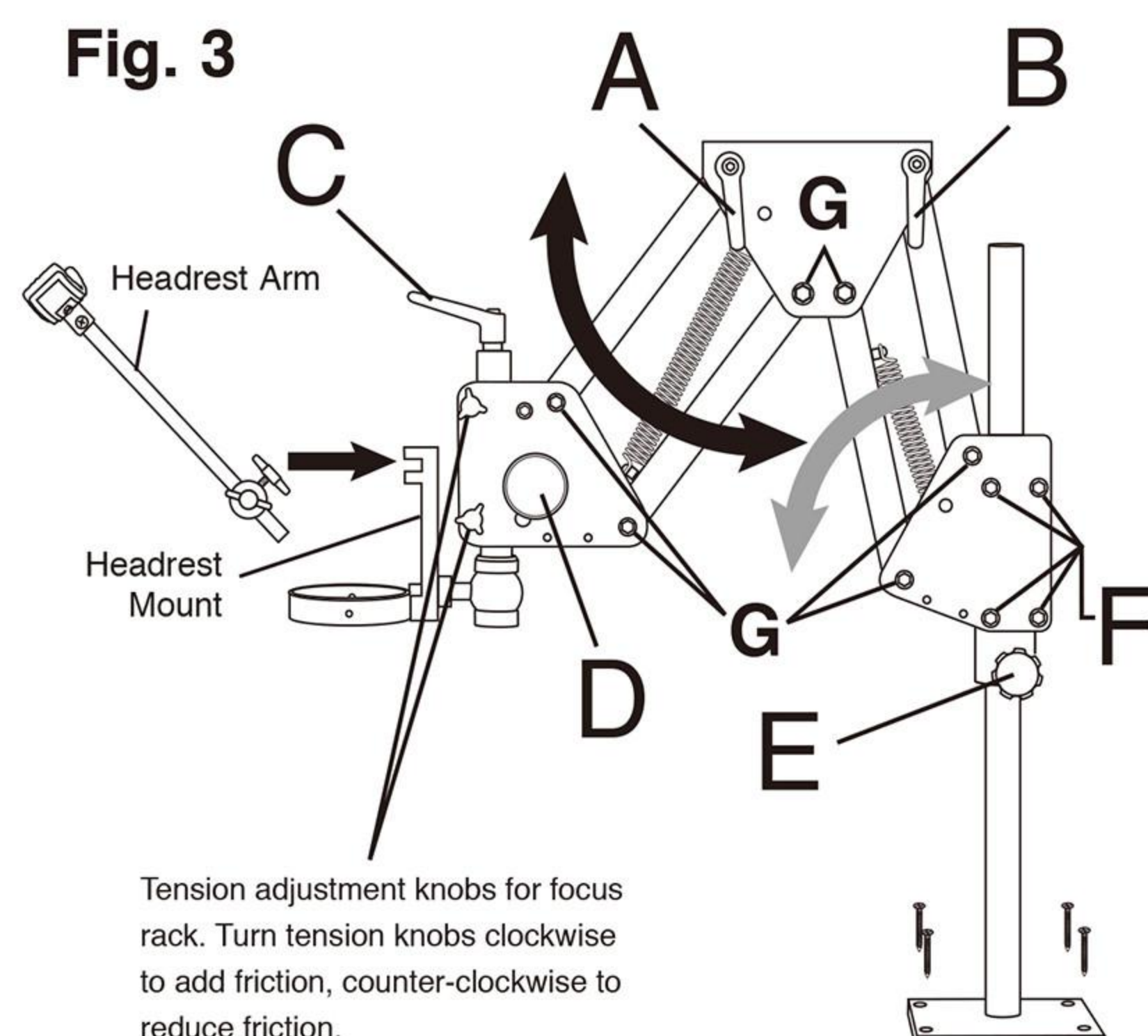
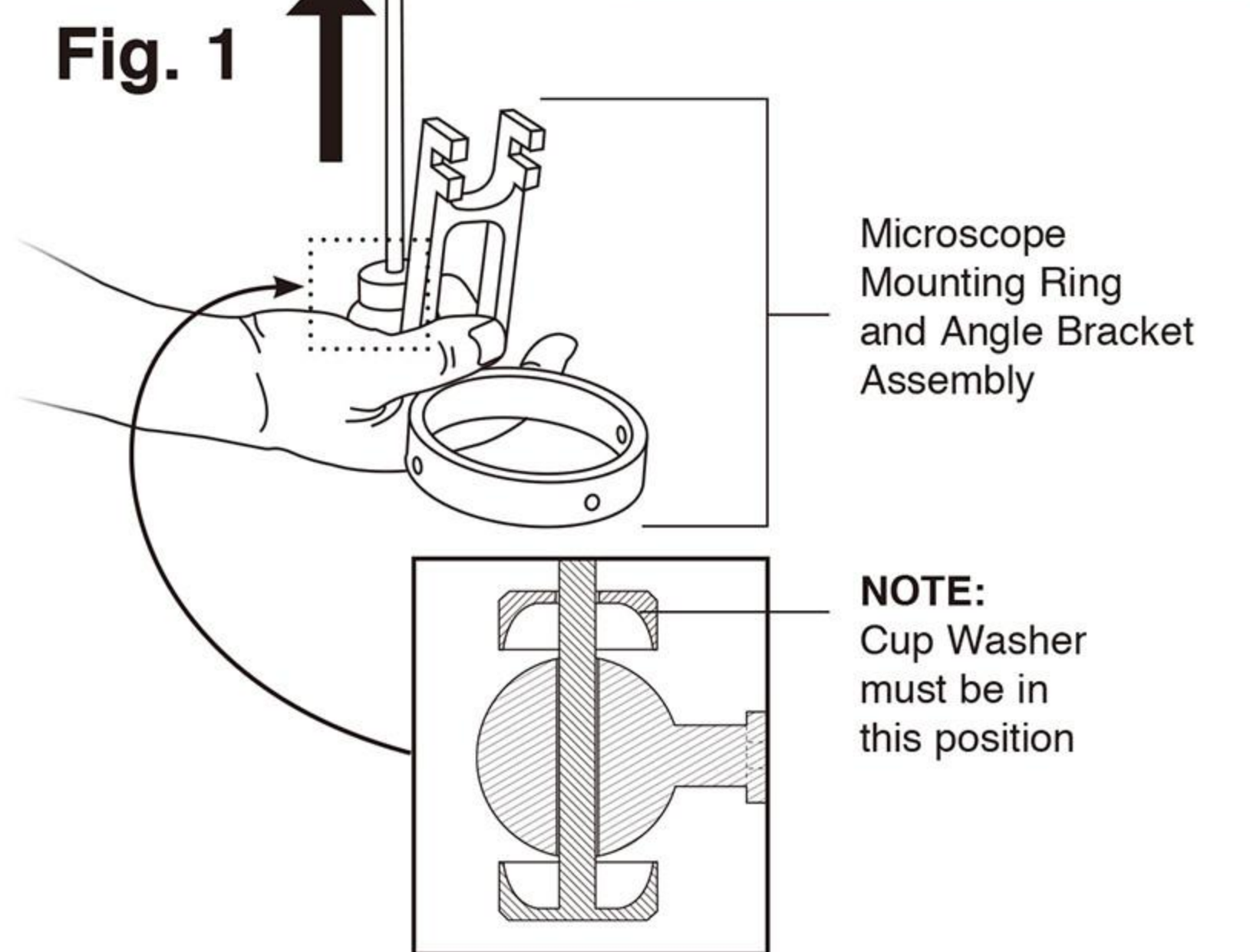

MICROSCOPE STAND BASE TEMPLATE ZQ-1

For Wood Top Benches

Decide where to locate the microscope stand on your bench top. Make sure there is plenty of "reach" so the microscope is over your work. Using the template below, tape it exactly where the base will be located. With a center punch or awl mark the centers of the screw holes through the paper and into the bench top. Remove the template and drill a starter hole for the screws using a 1/8" drill bit. Drill all four holes a little more than 1" deep. Hold the drill as square to the surface as possible. Attach the stand to the bench with the 1-1/2" wood screws that are included in the package. Be sure to tighten the screws so that the heads rest tight against the metal base. If you are having trouble setting the screws you probably did not drill the holes deep enough.

For Metal Top Benches

It is advisable to use 10-32 flat head bolts (not included) with a length of about 1/2" more than the thickness of your bench top. Use the template below as described above to locate the centers and drill 1/4" holes through the bench top. Bolt the stand down using washers and nuts on the underside. If the bench top is made of a sheet metal with a lightweight substrate we recommend adding a board or metal plate to the underside for extra strength.

