

VEVOR[®]

**COMMERCIAL SLUSH MACHINE SERIES
PRODUCT INSTRUCTION MANUAL**

XRJF-11

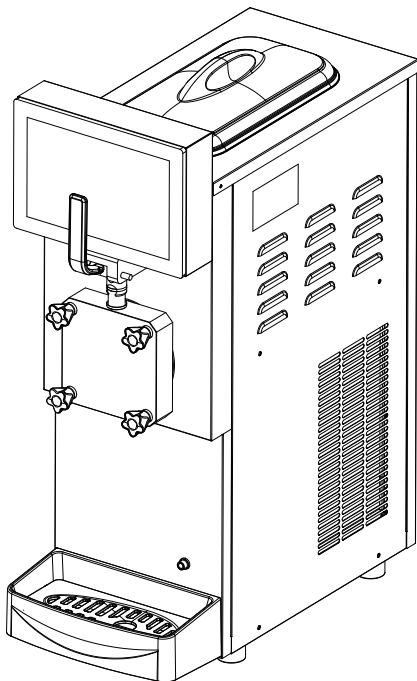

NEED HELP? CONTACT US!

Have product questions? Need technical support? Please feel free to contact us:



CustomerService@vevor.com

This is the original instruction, Please read all manual instructions carefully before operating. VEVOR reserves clear interpretation of our user manual. The appearance of the product shall be subject to the product you received. Please forgive us that we won't inform you again if there is any technology or software updates on our product.

Content

1. Safety Instructions	03
2. Installation Instructions for The Whole Machine.....	06
3. Names of Each Part.....	07
4. Product Specifications.....	08
5. Operating Instructions.....	08
6. Out-of-Material Alarm Function.....	10
7. Slush Production.....	11
8. Simple Cleaning.....	12
9. Cleaning & Maintenance.....	12
10. Cleaning Method of Parts.....	13
11. The Assembly Method of The Component.....	14
12. Methods for Installing on The Machine.....	14
13. Troubleshooting Instructions.....	17
14. Circuit Diagram.....	19
15. Environmental List.....	20

Safety Instructions

Dear user,

Hello! Thank you for using our products, in order for you to better read this manual and use this product, and to prevent personal injury and object damage accidents, please be sure to read carefully and comply with the following symbols in this manual.

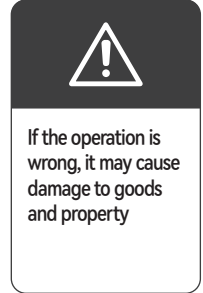
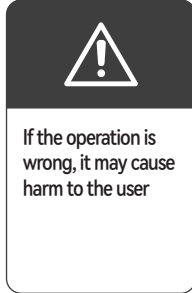

Be sure to store this book in a location where users can access it at any time

Electrical Requirements



Be sure to use the power supply specified on the nameplate of this slushy machine; if the voltage fluctuation range is large, please install an automatic voltage regulator suitable for power according to the nameplate parameters.



It is necessary to use a separate dedicated socket and reliably grounded, and the power cord of this series of slushy machines is equipped with a three-wire (grounded) plug which should be used. Conforms to standard three-wire (grounded) sockets. Never remove the third pin (ground) of the power cord under any circumstances.



The power cord plug should remain in firm contact with the outlet, otherwise it may cause a fire. In order to prevent damage to the power cord, do not let the slushy machine press the power cord or artificially step on the power cord, when moving the slushy machine, please be careful and cautious, do not roll the power cord, otherwise the right side of the power supply software can be damaged, causing electric shock or fire accidents.



Do not pull the plug of the slushy machine by pulling the power cord, hold the plug tightly and pull it directly from the socket.
Before cleaning, repairing and replacing damaged lighting equipment, the power plug of the slushy machine must be unplugged to prevent electric shock.
Do not use the power cord if it is damaged or the plug is worn, and it must be replaced at the maintenance point designated by the manufacturer.



When there is a leakage of flammable gases such as gas, the valve of the gas leakage should be closed immediately, and then the doors and windows should be opened, and the plug of electrical devices such as the slushy machines should not be unplugged or plugged.



Please install a leakage off circuit protector before use to ensure personal safety and safe use of the product.

Usage



No trial operation shall be carried out without the guidance of a professional, otherwise it may cause the failure of the machine and safety accidents.



Do not put your finger in the feeder of the pot, otherwise it may cause finger injury or machine failure.

Before disassembling and cleaning the discharge valve and agitator, the power supply must be turned off, otherwise it may cause personal injury.



Do not spray with water to, rinse the slushy machine, and do not place the slushy machine in a wet place that is easy to splash water, so as not to affect the electrical insulation performance of the slushy machine. It may even lead to accidents such as electric shock and fire.



It is strictly forbidden to disassemble and transform the slushy machine, and it is forbidden to artificially damage the refrigeration pipeline. Repairs of the slushy machines must be carried out by qualified personnel.

In the event of an abnormality or failure, please unplug the power supply, and stop using it, and if you need repairs, you must contact the designated maintenance point.

When the slushy machine is not used for a long time, please unplug the power plug, otherwise the aging of the insulation layer will cause a leakage fire.



Please pay attention to the care of children, prevent children from sticking their hands, feet, etc. into the slushy machine compartment, back and other gold layer protective parts of the punching holes, edge seams, so as not to cause harm to the body.

When the slushy machine is not in use, please close the door of the slushy machine and do not let children play.



This appliance contains flammable materials that must be disposed of and recycled by qualified personnel and institutions when discarded.



This appliance contains combustible blowing agent, beware of fire, (the product has the mark of "beware of fire"). When there is an abnormality in the product, it must be repaired by relevant qualified personnel and institutions.



This machine is not intended for use by persons with frailty, children, retardation, or mental disorders, except under the guidance or assistance of a person responsible for safety. Children should be supervised to ensure that children do not play with machines.



If the power cord is damaged, it must be repaired by a professional.



In the vicinity of slushy machine, do not store or use gasoline and other flammable items to avoid causing a fire. Explosives, such as combustion sprays, shall not be stored in utensils.

Usage Environment



The slushy machine needs to be placed on a flat and solid ground and withdraw from the packaging base, and if it is necessary to raise it, it is also necessary to choose a smooth, hard, non-burning countertop, otherwise it may cause dumping, noise, and excessive vibration. Slushy machine should not be placed in places that are wet or susceptible to splashing water, otherwise they will cause fires or electric shock.



Away from the heat source, the slushy machine should not be installed near the stove, oven or other equipment that generates high temperatures, and try to avoid direct sunlight so as not to affect the heat dissipation of the machine.



Avoid direct sunlight, if the slushy machine is installed in direct sunlight, it may cause abnormal operation and may shorten the working life of the slushy machine.



This series of slushy machine is not suitable for outdoor use. Normal operating ambient temperature is 3° C-32° C/37.4° F-89.6° F. The normal working water temperature is 0.6° C-32° C /33.08°F-89.6°F. Do not use in places with a lot of sulfuric acid components such as hot springs, or in places with a lot of salt near bays. Otherwise, it may cause corrosion inside the machine and cause machine failure.



Avoid placing slushy machine in wet areas, such as near faucet attachments or sinks.



This appliance is used for similar purposes: e.g. in the kitchen area of a shop, office or other workplaces; Customers of farms and hotels, motels and residential environments; Family hotel environment; Restaurants and similar non-retail applications.

Installation Instructions for The Whole Machine

Installation of Slushy Machine

1. Remove all packaging components.
2. Check if the machine is damaged during transportation, and then remove the attachments.
3. This series of slushy machine should be placed in a clean place with air circulation, not suitable for open air, not suitable for direct sunlight and rain, nor can it be placed near the heat source.
4. The ambient temperature around the series of machines should not be less than 3 °C/37.4°F, not higher than 38 °C/100.4°F, and the appropriate spacing should be retained around the four sides to maximize the efficiency of the slushy machine and the heat dissipation of the machine.
5. When the slushy machine is installed, please place the slushy machine horizontally, and items cannot be placed on the top.

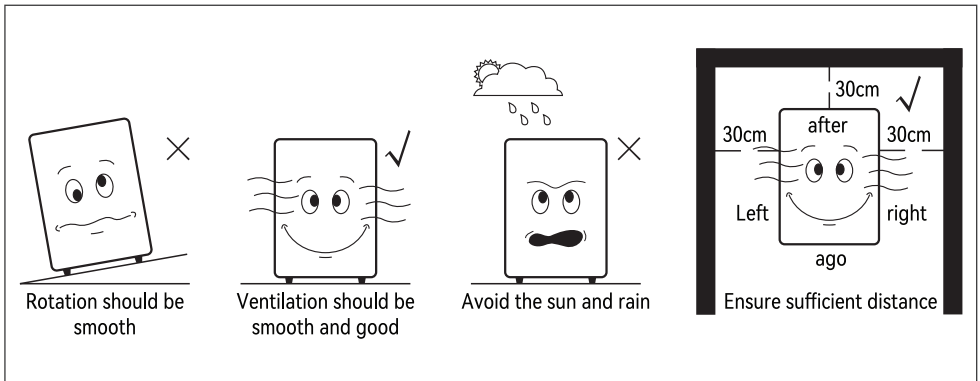

WARNING

When moving, the box should be kept as straight as possible, and the maximum tilt should not exceed 45°. When moving, please ensure that there are at least two or more people, and avoid upside down and horizontal placement. The maximum stack cannot exceed 2 layers.

Installation of the Power Supply

1. The power supply connected should be the same as the one indicated on the nameplate of the machine.
2. Do not connect other electrical appliances to the same outlet.
3. Y-type connection, must be replaced by the manufacturer, service agencies or qualified personnel to connect the power cord.
4. The power plug should be plugged directly into a power outlet with a ground wire, not into a temporary terminal block. All wiring must comply with national or regional standards.
5. Voltage fluctuations shall not exceed $\pm 10\%$ of the rated voltage, otherwise a voltage regulator shall be installed.

Pre-boot Inspection

1. Is the slushy machine placed horizontally?
2. Is there any problem with the power outlet?
3. Whether the access to the power supply is consistent with the one marked on the machine nameplate.

Proper Operation When Using

1. Do not place items on the top cover of this machine, otherwise it will cause noise.
2. The left, right and rear sides of the machine must have sufficient heat dissipation space, otherwise it will affect the heat dissipation, and the production capacity of the machine affected by the air-cooled circulation channel, and it is forbidden to place items around.
3. The slushy machine should be kept away from the heat source, it is strictly forbidden to use it in a high or low temperature environment, and the direct sunlight should be avoided as much as possible so as not to affect the heat dissipation of the machine.
4. Sterilization should be carried out daily. Otherwise, bacterial multiplication can be detrimental to health.
5. If the slushy machine is placed for a long time, please disassemble and wash it, turn off the power plug, please carefully dry the water of the material tank and the freezing tank; after they are dried and then covered with the material basin cover for safekeeping.

Names of Each Part

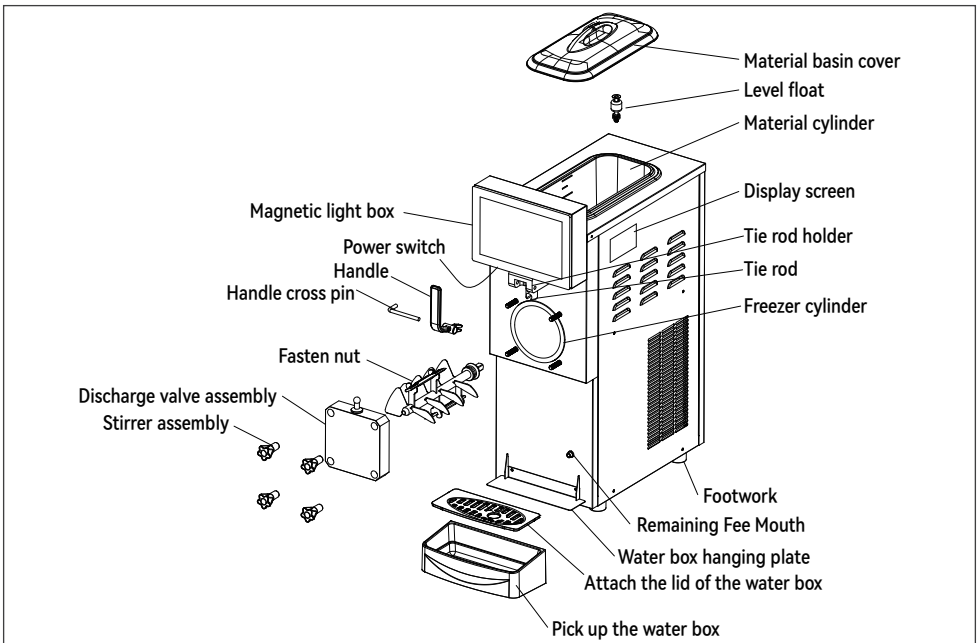

Discharge Valve Assembly

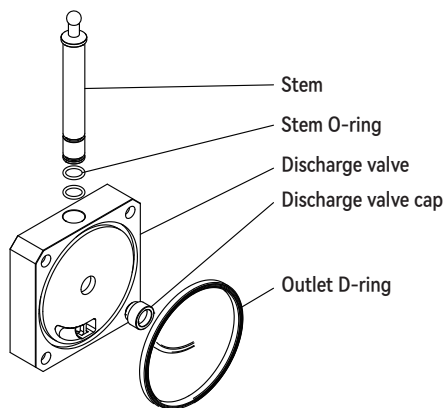

Agitator Components

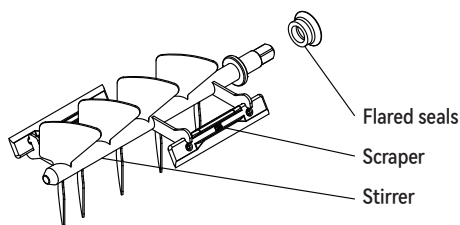

Product Specifications

Model	XRJF-11
Refrigerating Capacity	15-25L/H
Climate Type	N/SN
Refrigerating	R410/380g
Input Power	1550W
Rated Voltage	AC120V 60Hz
Foam Material	Cyclopentane
Net Weight	54KG
Dimensions	635*290*860mm

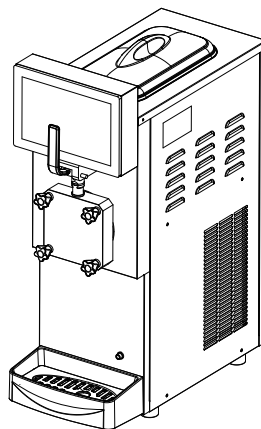

Operating Instructions



To prevent accidental movement, the button needs to be pressed slightly harder. When switching between keys, press the Stop button first, then switch. For safety reasons, no buttons can be operated without an outlet valve installed.

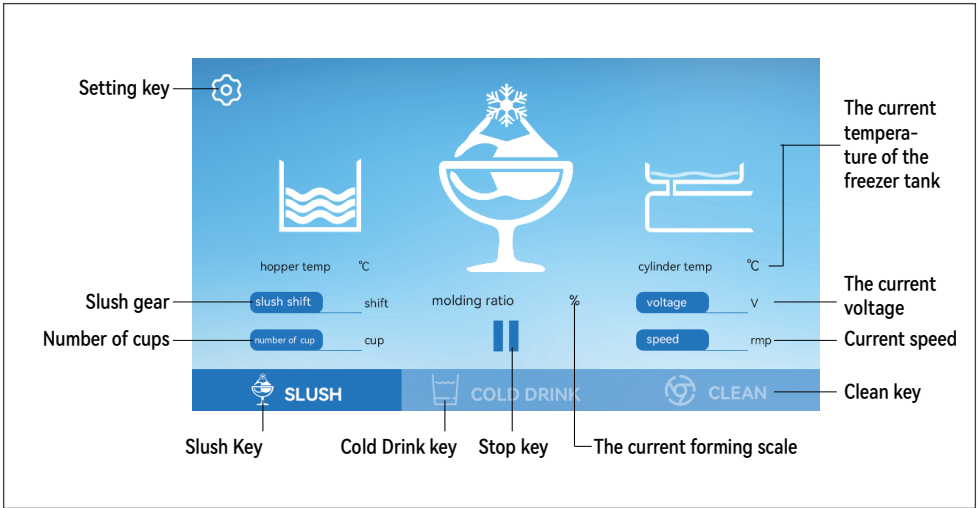

Instructions: Press "Stop", "Clean", "Slush", "Cold Drink" on the touch screen to enter the corresponding working mode.

It is normal for the current temperature of the freezer tank to deviate from the actual temperature of the raw material in the cylinder. The freezer temperature is not involved in forming control when making snow melt.

Password Input Interface

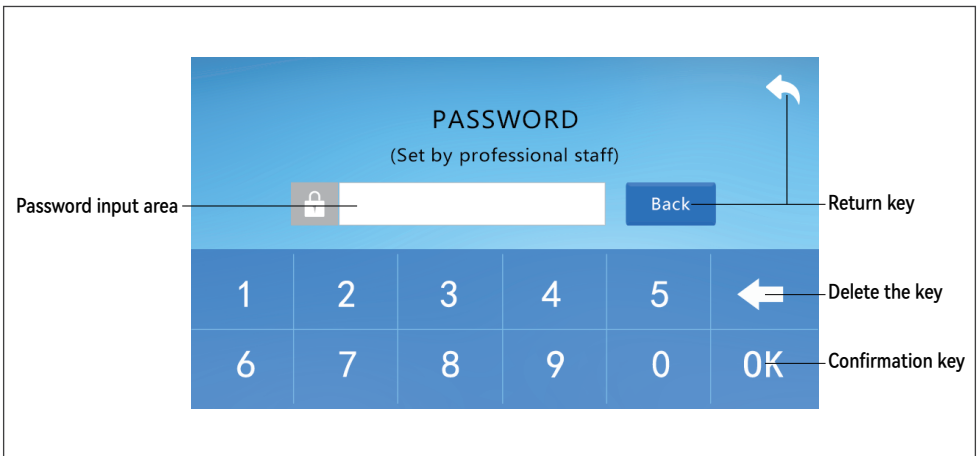

On the password input interface, click the password input area and enter the password "666666" and then click "OK" to enter the parameter setting interface.

Parameter Setting Interface

Slush gear: 1-8 gears can be adjusted according to "plus" or "minus" gear adjustment, The default is 3 gears, the higher the gear, the harder the smoothie is, and the lower the gear, the softer the smoothie is.

Slush cycle time: This time is adjusted for the refrigeration system after 100% slush molding Stop time, 5-20 minutes can be adjusted according to "plus" or "minus" for gear adjustment The default is 10 minutes.

Preservation temperature: set the pan preservation temperature, 5 °C-15 °C adjustable, the default is 10 °C.

Cold drink temperature: Set the cold drink refrigeration shutdown temperature, 2 °C -10 °C can be adjusted, the default is 7 °C.

Number of cups: Record the number of discharged cups for machine slush and cold drinks, and clear the data by "clearing" minus.

Factory reset: All the data set by the user is cleared and restored to the parameters set by the factory settings.

Next: Go to System 2 (Right Cylinder System) User Settings.

Note: All user setting parameters are equipped with power-off saving function, and the settings are automatically saved after returning.

Out-of-Material Alarm Function

Level float

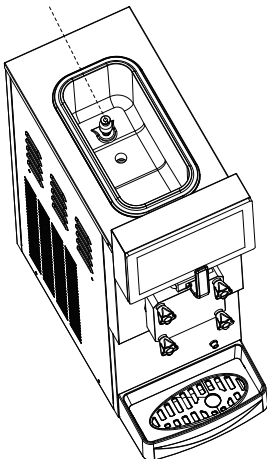

The bottom of the tank is equipped with a level float, any one of the tank level floats at a low level, report a lack of materials, add raw materials to the tank level float to float, and the lack of material alarm is closed.

Slush Production

1.Raw Material Preparation

According to the manufacturer's operating instructions, dilute the concentrate with water and stir in a suitable container. The mixture contains sugars, the amount of which should be kept between 13%-18%. Lower and higher concentrations can be destroyed agitators and stirring motors.

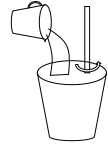

2.Raw Material Filling

Before adding the raw materials, try to ensure that there is no residual moisture in the freezing tank during cleaning. Check the discharge valve assembly, whether it is installed in place, and whether the four fastening nuts are twisted. Inject about 6 liters of slush raw material into the material tank, (The single-tank slushy machine can pour up to about 10 liters of raw material into the material tank.)

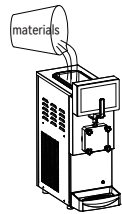

3.Start The Machine

Refer to the operating instructions
Note: When the machine is in working condition, do not put your fingers into the feed bowl raw material supply port. Failure to do so may result in finger injuries or machine malfunction.

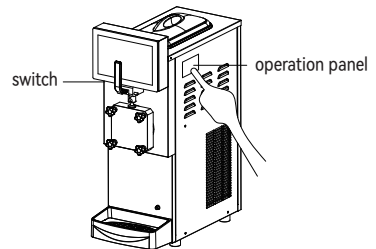

4.Make Smoothies

When the shape ratio reaches 99% and the machine is automatically stopped, it means that the smoothie is ready. Simply pull the handle down to punch out the smoothie.

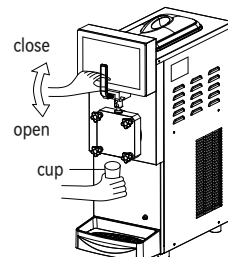

Simple Cleaning

1. Release all the ingredients
2. Power off the machine
3. Fill the material tank with an appropriate amount of food detergent to prepare hot water that does not exceed 50 ° C, then open the tank cover and pour the hot water into the tank.
4. Turn on the power of the machine, then press the wash button and let the agitator stir for 2-3 minutes.
5. Release all the water from the tank, and then repeat the operation more than 2-4 times.
6. Turn off stirring and power.

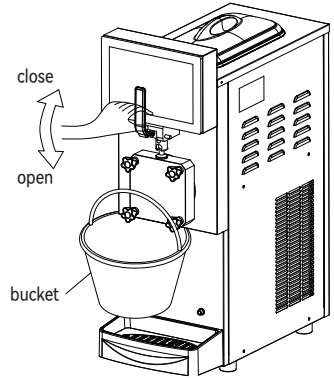

NOTICE

Note: Please pour clean water into the corresponding basin to be cleaned, do not exceed the highest marking line on the tank, if you want to clean the machine thoroughly, please turn off the machine power.

Cleaning & Maintenance

Be sure to unplug and turn off the power supply before cleaning.

Before any cleaning or maintenance, be sure to bring protective equipment (glove, safety glasses, etc.), which ensure your safety.

Please do not rinse the slushy with water spray, so as not to affect the insulation performance of the electrical appliances, caused leakage hazard.

Do not use hard bristle brushes, wire brushes, nor detergent powders, gasoline, or bananas, water, acetone and other organic solvents, boiling water or acids, alkalis, etc. to clean the slushy machine; improper use will cause damage to the slushy machine material and affect the service life.

When cleaning a location with warning signs, be careful not to scratch your hands.

Wash with disinfectant that meets food hygiene requirements.

Use a suitable food-grade neutral cleaning agent to avoid damaging parts.

The following items can damage the surface of the slush.

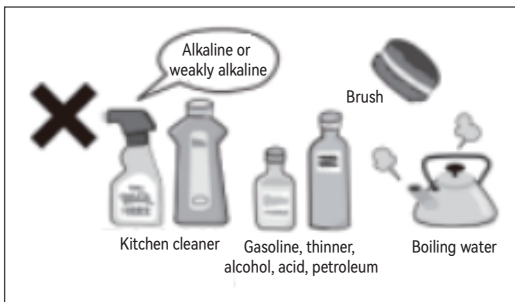

Cleaning Method of Parts

When using it for the first time or not using it for a long time, please clean the parts before use.

Use food detergent and cleaning brushes to clean all parts that have been disassembled

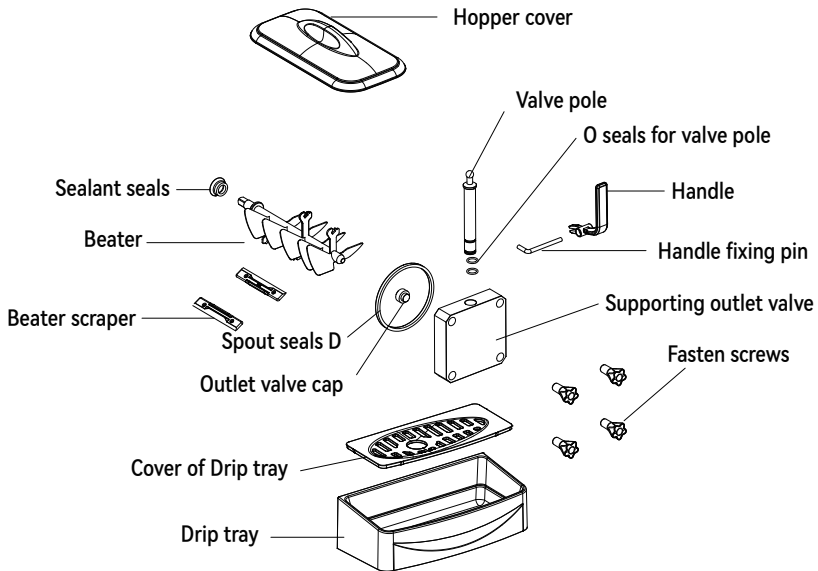

User Considerations

Do not damage or lose components during operation.

Do not wash resin parts with hot water or a dishwashing machine. Failure to do so may cause deformation.

Do not soak parts in detergents or germicidal solutions for more than 30 minutes. Failure to do so may cause deterioration.

For some areas that are prone to accumulation of residual material, please wash carefully with a cleaning brush.

Some parts have pointed edges, be careful not to scratch your hands.

Carefully wash the agitator with a washing brush, including the middle part.

The Assembly Method of The Component

Assembly of The Valve Stem

1. Install the O-ring on the valve stem and assemble it according to the diagram.
2. After the O-ring is installed, the surface is greased.

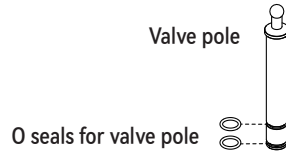

Assembly of Agitator Components

1. The flared sealing ring is lubricated at both ends.
2. Install the flared seal directly behind the agitator.
3. Mount the scraper on the agitator. The spatula arrangement in the agitator is loose.

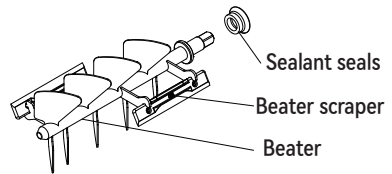

Assembly of Discharge Valves

1. Insert the greased stem of the installed O-ring into the outlet hole of the discharge head.
2. Install the D-ring on the discharge head mounting slot.

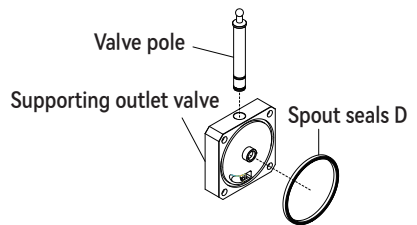

Methods for Installing on The Machine



When assembling and disassembling parts, turn off the control power switch. Otherwise, it is possible to accidentally touch the starting machine and cause injuries to the person.

Disinfect your hands and fingers during operation. Otherwise, it may endanger human health.

Mounting of The Handle

Insert the handle socket into the lever pin, then insert the handle pin into the lever holder, and then align the handle pin hole with the vel pin, and then the vel pin goes directly through the handle pin hole.

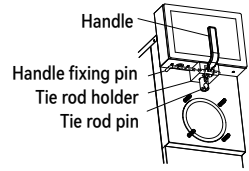

Installation of Agitators

It is important to ensure that the control power switch is turned off. Confirm that the display is off. Insert the agitator into the freezer tank and slowly rotate the agitator with your hands to embed the quad head of the reducer into the quad connector of the reducer.

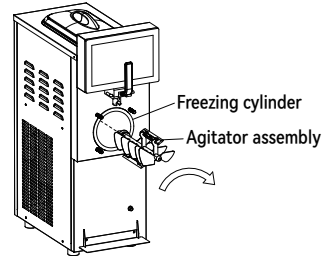

Installation of Discharge Manifolds

The four mounting holes of the discharge valve are passed through the four discharge heads to fix the bolts, the stem head is stuck into the lever clamp position, and then the four fastening nuts are evenly fastened diagonally.

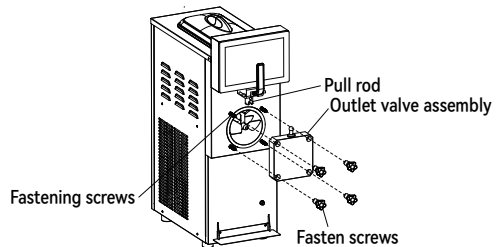

Installation of Discharge Manifolds

The four mounting holes of the discharge valve are passed through the four discharge heads to fix the bolts, the stem head is stuck into the lever clamp position, and then the four fastening nuts are evenly fastened diagonally.

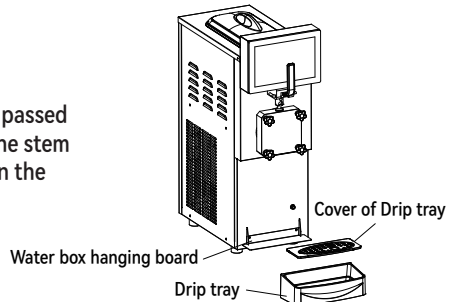

Cleaning And Maintenance of The Enclosure

Be sure to unplug the power supply and turn off the water source before cleaning. Do not plug the power supply with wet hands, or there will be a risk of electric shock.

Wipe the surface of the slushy machine shell by using a soft towel or sponge dipped in warm water (a diluted neutral detergent is available).

After washing with detergent, wipe it off promptly with a soft cloth or sponge dipped in water.

Wipe the water off the surface of the enclosure with a dry cloth.

Please never spill water directly on the machine. Failure to do so may result in a power leakage or accident.

Check once or twice a month to confirm whether the power cord is damaged.

Cleaning of The Condenser

After working for a period of time, the condenser will be dusty and affect the heat dissipation, and the cooling effect will become worse

(Manifested as: the output of the slush decreases or the slush is difficult to be formed), please clean once every three months (if the using environment is poor, please clean once a month), be sure to ask a professional cleaner to clean, turn off the power before cleaning, and pay attention not to damage condenser fins of the vessel.

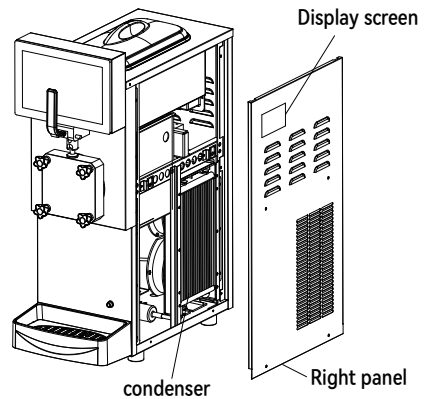

Do not touch the condenser fins directly with your hands as this can cause injury. When disassembling the right panel, pay attention to the display protection.

Consumable Parts

Even if there are scars on the sealing ring that cannot be seen with the naked eye, it may cause problems such as "slush leakage", so please replace the new product regularly with a rough replacement period of three months. Even within the replacement period, if there is a problem such as scars, please replace it in time.



O seals for valve pole



Sealant seals

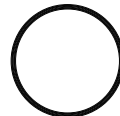

Spout seals D

Troubleshooting Instructions

The slushy machine you receive is a mechatronic professional equipment that integrates computer program control, mechanical transmission and efficient refrigeration system! You must arrange for your own personnel to be responsible for the operation and maintenance of this equipment, at the same time, please understand the installation and maintenance requirements of this equipment in detail when purchasing the machine, and receive professional training before use!!! (Very important) For the violation of the installation, use and maintenance requirements of the machine caused by equipment failure, is not within the scope of the company's warranty!
 At the same time, for the problems encountered in the process of use, please strictly follow the following precautions:

Serial number		Cause Analysis	Processing method
1	No display after power on	Is the power switch of the equipment energized	Check the power supply, plugs and sockets
		The internal wires of the machine are chewed or loosened by rats	Hire a professional electrician to replace or fix
		The computer board of the equipment fails	Call the company's phone number to be handled by the company's professional staff
2	Power switch tripped after power on	Insufficient input power line or switch load	Hire your own professional electrician for replacement
		The internal circuit of the equipment is chewed or broken by rats	Hire a professional electrician to replace or wrap
		Excessive load on equipment due to high gear setting	Downward gear adjustment
		Short circuit inside the motor, circuit board or compressor	Call the company's phone number to be handled by the company's professional staff
3	Feeling of leakage after power on	The machine case has inductive electricity	Check whether the power inlet line is reliably grounded, no grounding wire; if it is worn, you need to replace it with a new one
4	Leakage of water and material on or under the discharge head after starting the machine	D-seal is not installed properly	Check whether the two D-rings of the outlet valve are installed in the slot
		Broken O-ring of beating rod	Take down the beating rod to check whether the seal at both ends is worn, there is wear need to replace the new
		Fastening screws are not tightened	Tighten the four screws evenly diagonally
		Incorrect disassembly or installation method of beating rod, resulting in broken beating rod seal and leakage of material or water	Gently pull out vertically when disassembling, and always apply medical petroleum jelly as lubricant when installing, apply it around the valve stem seal and press down vertically. Do not damage the seal with sharp objects when cleaning.
5	The residual material pipe leaked material and water	The discharge head screw is not tightened	Tighten the four screws evenly diagonally
		Worn seal at the back end of the agitator	Replace rear end seal

6	Abnormal noise after power on	The machine is noisy when pressing the cleaning key	The cleaning noise will gradually reduce after adding raw materials
			The ground on which the machine is placed is not horizontal, adjust by yourself
		The machine is noisy when cooling	The noise will be reduced gradually after adding material when there is a lack of material.
			The gear setting is too high, adjust the gear by yourself
		Fan noise	Self-check whether there are foreign objects around the fan blades and whether the fixing screws of fan bracket are loose
			Check whether the wind blade rubs the nest shell when rotating
			Check whether the fixing screws of condenser are loose
		Motor noise	Noise generated by too high gear setting
			Noise of the motor itself
			The fixing screws of motor are loose
		Compressor noise	Condenser has not been cleaned for a long time, the condenser is too dirty resulting in excessive compressor load
			Internal piping deformation causes vibration noise
	Compressor normal noise		
7	Smoothie discharges are too soft or too little	Too frequent discharge	Wait until the molding ratio reaches 90% or more before mixing the material
		Poor heat dissipation	Solve the problem of ventilation on both sides of the machine, leave at least one meter of space on both sides
		Not enough gears	Adjusting gears
		Machine cooling system failure	Refrigerant leakage or compressor failure
8	No smoothie or too soft after stopping the machine	The beating handle is not in place	When the handle does not hit downward, the beater switch is not closed and the machine does not start
		The first cup is softer after stopping the machine	Start after a long shutdown, it's normal for the first cup to be softer
		Gear setting too high or too low	Proper gear adjustment
		Downtime setting is too long	Appropriate adjustment of downtime
		Discharge micro switch failure	Replacement of discharge micro switch
9	Machine LL Alarm	Sensing anomalies	Check if there are magnets on the motor or adjust the speed sensor position or replace
		Long buzzer sound, the whole machine stops working	Check if the sensor is out of position or the connection wire is disconnected

10	Machine 55 alarm	Tank freezes	Proper downward adjustment of gear
		Motor does not rotate or motor idling speed is slow	Call the company's phone number to be handled by the company's professional staff
		Sensor failure or loose sensor linkage	Call the company's phone number to be handled by the company's professional staff
		Slow motor speed	Check if the motor is damaged
11	Unable to reach "99"	Improper gear selection	Proper downward adjustment of gear
		Poor cooling	Check whether the condenser is dirty and blocked, whether the exhaust air is smooth and the refrigerant is less
		The ring temperature is too high, ventilation and heat dissipation is not good or the air inlet and outlet are blocked	Ensure that the equipment is in a ventilated position and remove obstacles from the air inlet and outlet
		Unstable voltage or insufficient power supply capacity	Ask a professional to handle it
		Refrigeration evaporation cylinder frosts badly or has no frost in the return air pipe when empty	Leakage of slush
12	"UH" alarm	High voltage alarm	Adjust the voltage or add a 6KW regulator
13	"UL" alarm	Low voltage alarm	Adjust the voltage or add a 6KW regulator
14	"CH" alarm	Freshness and temperature sensor open or short circuit	Replace the sensor
15	"AH" alarm	Freshness and temperature sensor open or short circuit	Replace the sensor

Circuit Diagram

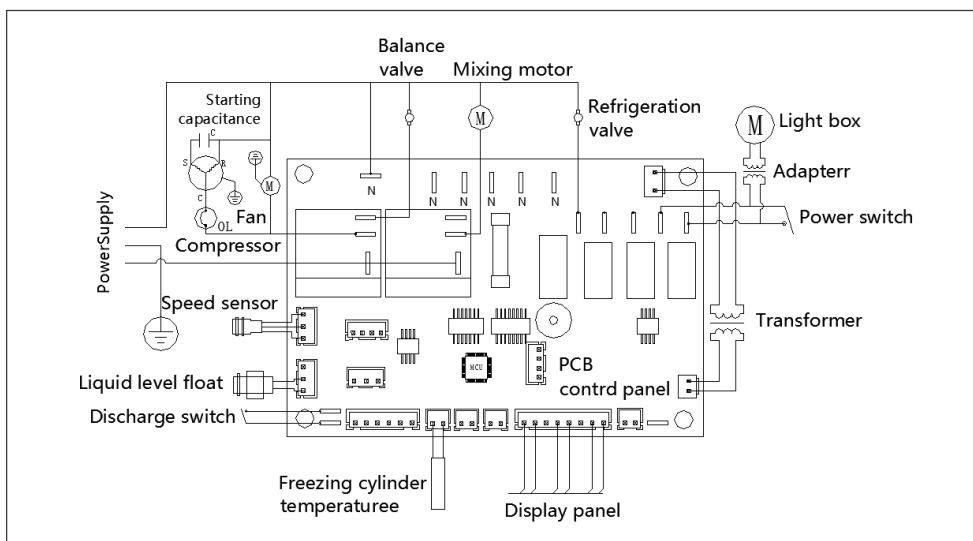

Environmental List

1. The name and content of non-environmentally friendly substances or elements in the product.

The part name	Non-environmentally friendly substances or no substances					
	lead	mercury	cadmium	Hexavalent chromium	Polybrominated biphenyls	Polybrominated diphenyl ethers
	Pb	Hg	Cd	Cr(vl)	PBB	PBDE
Compressor	✘	○	✘	○	○	○
Fans	✘	○	○	○	○	○
Motor	✘	○	○	○	○	○
evaporator	✘	○	○	○	○	○

○ : Indicates that the content of the hazardous substance in all homogeneous materials of the part is below the limit requirements specified in GB/T 26572.
 ✘ : Indicates that the content of the hazardous substance in at least one of the homogeneous materials of the component exceeds the limit requirements specified in GB/T 26572.
Note: The components of this product are made of non-toxic and harmless green environmental protection materials, and the non-environmentally friendly substances or elements contained in this product are due to global technology
 The level of surgery and craftsmanship is limited and it is not possible to achieve complete substitution of non-environmentally friendly substances or elements, but the content of non-environmentally friendly substances or elements in this product
 Extremely little, long-term use will not cause harm to the human body, please rest assured to use.

2. Description of the environmental label:

This product is purchased in accordance with the relevant provisions of the national regulations "Measures for the Administration of the Restricted Use of Hazardous Substances in Electrical and Electronic Products"

Electronic appliances and electrical appliances are used in the industry standard "SJ/T 11364 Requirements for the Restriction of the Use of Hazardous Substances in Electrical and Electronic Products" Product hazardous substance control mark.



3. Instructions for the recycling of waste electrical and electronic products :

In order to better care for and protect the earth, when the user no longer needs this product or the product is end-of-life, please comply with the relevant laws and regulations on the recycling of waste electronic and electrical products in the country of use shall be handed over to the local recycling with national approval The processing qualified manufacturer carries out recycling.

Any product with a cross-label of the wheeled trash can is a reminder of the obligation to sort and recycle waste. Research on the proper disposal of discarded products will promote environmental protection.



Manufacturer: Hubei Guangshen Electric CO.,Ltd

ADD: Xian'an Economic Development Zone, Xianning City, Hubei Province

Importer: FREE MOOD LTD

Address: 2 Holywell Lane, London, England, EC2A 3ET

UK	REP	EUREP UK LTD UNIT 2264, 100 OCK STREET, ABINGDON OXFORDSHIRE ENGLAND OX14 5DH
-----------	------------	---

Importer: WAITCHX

Address: 250 bis boulevard Saint-Germain 75007 Paris

EC	REP	EUREP GmbH Unterlettenweg 1a, 85051 Ingolstadt, Germany
-----------	------------	---

E-mail: CustomerService@vevor.com

VEVOR[®]

E-mail: CustomerService@vevor.com