

VEVOR[®]

TOUGH TOOLS, HALF PRICE

Technical Support and E-Warranty Certificate www.vevor.com/support

ELECTRONIC DRINK MIXER

USER'S MANUAL

Model: DM11-U/DM12-U/DM13-U

We continue to be committed to provide you tools with competitive price.

"Save Half", "Half Price" or any other similar expressions used by us only represents an estimate of savings you might benefit from buying certain tools with us compared to the major top brands and does not necessarily mean to cover all categories of tools offered by us. You are kindly reminded to verify carefully when you are placing an order with us if you are actually saving half in comparison with the top major brands.

VEVOR®

ELECTRONIC DRINK MIXER

TOUGH TOOLS, HALF PRICE

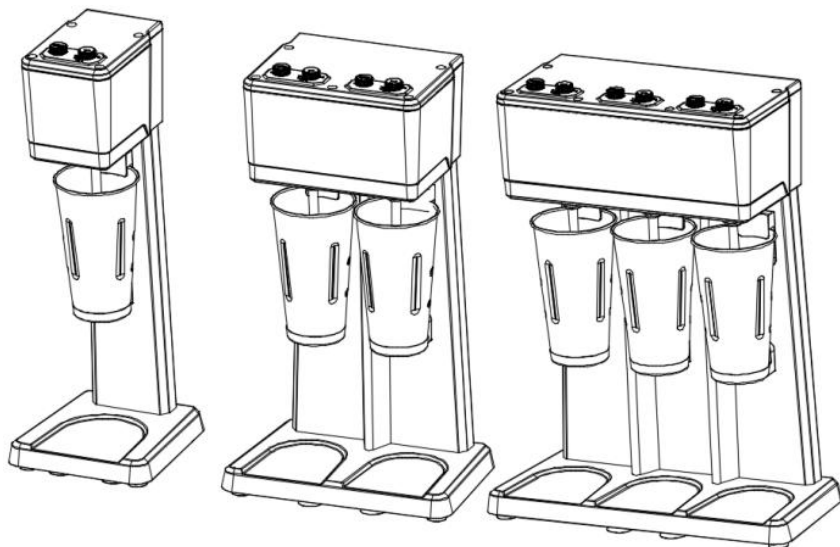



NEED HELP? CONTACT US!

Have product questions? Need technical support? Please feel free to contact us:

✉ CustomerService@vevor.com

This is the original instruction, please read all manual instructions carefully before operating. VEVOR reserves a clear interpretation of our user manual. The appearance of the product shall be subject to the product you received. Please forgive us that we won't inform you again if there are any technology or software updates on our product.

| | |
|---|--|
|  | <p>For your safety of this product, always read the instruction book carefully before using.</p> |
|  | <p>Alternating current</p> |
|  | <p>Connect an earth terminal to the ground</p> |

When using electrical appliances, basic safety precautions should be followed, including the following.

1. READ ALL INSTRUCTIONS.

2. Unplug from outlet when not in use, before putting on or taking off parts, and before cleaning.

3. Please check that the specified supply voltage in the product is consistent with the supply voltage(AC only).

4. This appliance can be used by children aged from 8 years and above and persons with reduced physical, sensory or mental capabilities or lack of experience and knowledge if they have been given supervision or instruction concerning use of the appliance in a safe way and understand the hazards involved.

5. Children shall not play with the appliance. Cleaning and user maintenance shall not be made by children without supervision.

6. To protect against electrical hazards, do not put the Drink Mixer in water or other liquids

7. Avoid contact with moving parts.

8. Do not operate the Drink Mixer or any other electrical equipment with a damaged cord or plug, or after the unit malfunctions or is dropped or damaged in any manner. Return it to the nearest authorized service facility for examination, repair, or adjustment.

9. Do not use outdoors. FOR HOUSEHOLD USE ONLY

10. Do not let the cord hang over the edge of the table or counter or touch hot surfaces.

11. Put this instruction manual in a safe place. Do not discard.

12. If the supply cord is damaged, it must be replaced by the manufacturer, its service agent or similarly qualified persons in order to avoid a hazard.
13. **Electric Shock Danger!** Non-professional personnel are forbidden to repair the products, otherwise it may result in electrical shock. When failures happen, it should be repaired by a qualified maintenance personnel.
14. **WARNING!** It is strictly prohibited to put the main body of the machine and the power cord into any liquid. The machine must be fully cool before cleaning.
15. Do not place the product directly on the fire or near the source of fire, otherwise the product will be damaged or even result in danger. Once part of the product is on fire, do not directly use water to extinguish the fire. Use a wet cloth to cover the fire site.
16. When the plug is plugged into the socket, it must be plugged to the end, otherwise it will cause the components overheating and burning due to poor contact.
17. Do not leave the product to work with no one watching. If the machine is overheating, please stop working immediately and unplug the power.

SAVE THESE INSTRUCTIONS

PRODUCTS SPECIFICATIONS

| Model | DM11-U | DM12-U | DM13-U |
|------------|------------------------|--------|--------|
| Voltage | AC 120V 60Hz | | |
| Rated Amp. | 1.1A | 2.0A | 3.3A |
| Speed | 3 speed setting +Pulse | | |
| Timer | 8 timing setting | | |

PARTS AND FEATURE

Explanation of the Product's components:

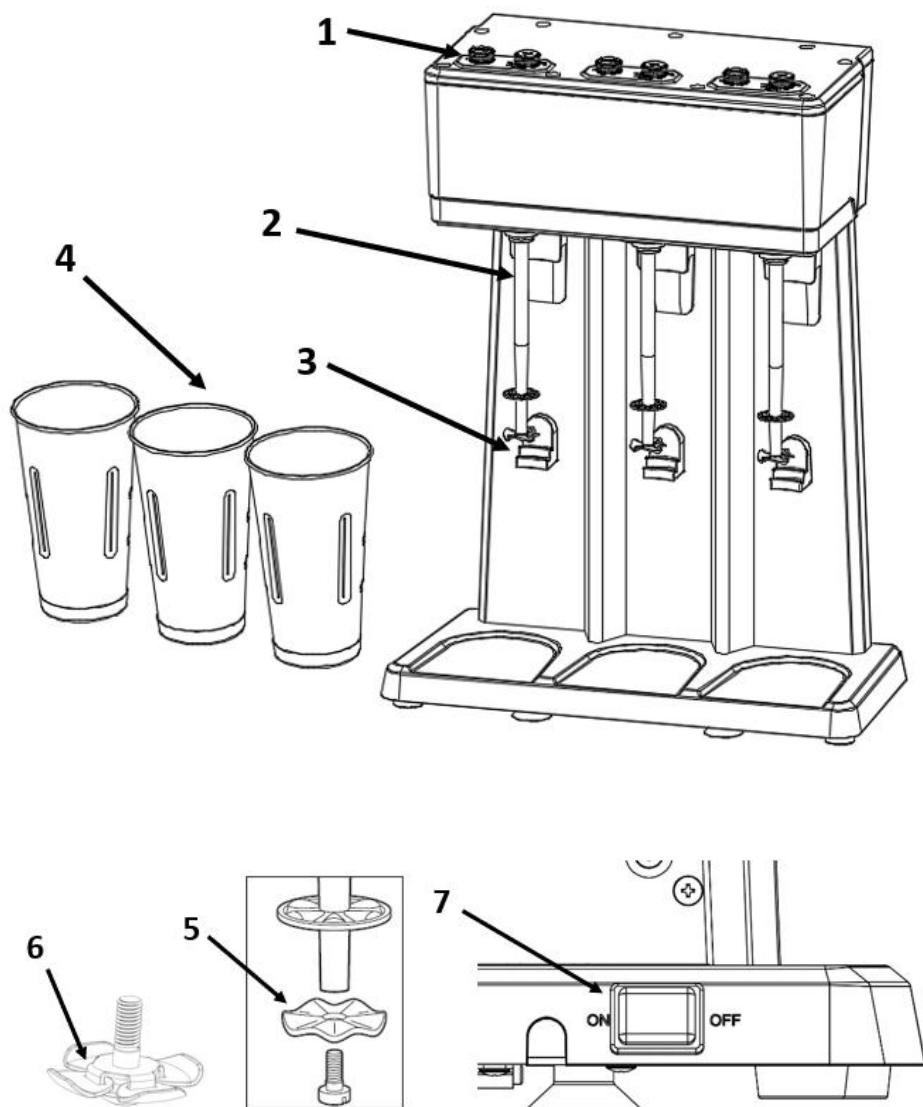

1. Control Switch
2. Cup Actuator (ON/OFF)
3. Cup Support
4. Mixing Cup
5. Solid Disk Agitators
6. Moving-Wing Agitators
7. POWER ON/OFF (at Back)

OPERATING THE DRINK MIXER

1. Plug in and Power ON.
2. Place the ingredients into the Mixing Cup.
3. Select the desired speed.
4. Position the Mixing Cup into Cup Actuator (#2) and move the cup upward to active the Motor.
5. The Cup Support (#3) has two steps. Motor will be active when Mixing cup is placed at Upper Step.
6. Motor will be OFF when Mixing cup is placed at Lower Step.
7. You may also turn the motor ON and OFF using the pulse without using Cup Actuator.

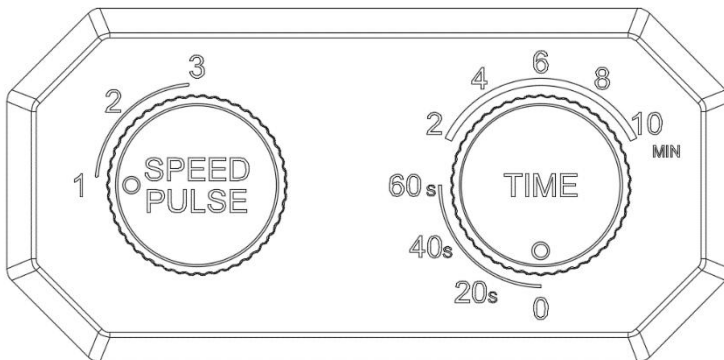

KEY Knob/Button

1. Speed Knob:

a. Choosing speed for LO, MED or HI

2. Pulse Button:

b. Press and hold Pulse Button and the mixer runs at the set speed until button is released.

3. Timer Knob

a. Select the desired time.

b. Timer will be activated, after placing the cup and actuating Motor.

c. After removing the Cup (or Motor Stopped), timer will reset to the selected Time.

d. Counting time is from Motor Start-up to final selection on knob. (Counting time do not accumulate)

The timers will need to be set individually if more than one timer in unit.

CHANGING AGITATORS

1. Unplug Drink Mixer

2. Loosen the screw/Agitator by turning it clockwise.

3. Remove the Agitator

4. Insert new agitator and screw back in.

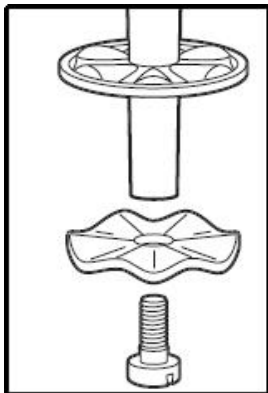

CLEANING

- TURN UNIT OFF USING POWER SWITCH LOCATED ON BACK OF UNIT, OR UNPLUG MIXER POWER CORD FROM ELECTRICAL OUTLET.
 - DO NOT PUT IT IN THE DISHWASHER
 - DO NOT IMMERSE APPLIANCE IN WATER OR OTHER LIQUID.
1. To clean the drink mixer, wipe with a damp cloth or spongy. Do not use abrasive cleaners of any type.
 2. To clean the mixing shaft, place 200ml warm, soapy water in Mixing Cup and place it on the mixer's normal operating position. Run on LO speed for 30 seconds—empty Cup. When finished, turn the unit OFF.
 3. Repeat Step 1 with warm water only to rinse mixer shaft.
 4. With unit turned to OFF, unplug unit and wipe residual soap and water from the mixing shaft with a damp cloth or sponge.
 5. The Mixing Cup should be washed in warm, soapy water or in a dishwasher.

HELPFUL HINTS

1. Always turn unit off or unplug the Drink Mixer before disassembling or assembling parts.
2. Keep all the instructions and service information in a safe and handy place.
3. For mixing heavy drinks, use HI speed only; for light drinks with more liquid, use LO speed.
4. If using ice, only use crushed ice in the Drink Mixer.
5. Clean the Drink Mixer thoroughly before initial use.
6. Keep mixing cups clean. Wash, rinse and sanitize thoroughly after use.
7. Be sure that all detachable parts are fastened tightly before operating the Drink Mixer.
8. Operate the Drink Mixer only when it is fully assembled.
9. To avoid splashing drinks of thin consistency, operate on Speed LO.
10. **Keep a firm grip on the cup while using PULSE.**
11. Moving-Wing Agitators is for soft ice cream.

12. The Basic Milkshake recipe is: 50ml ice cream +150ml cold Milk

TROUBLESHOOTING GUIDE

| | Problem | Solution |
|---|--|--|
| 1 | Ingredients are not being mixed Properly | Try select a different speed. |
| 2 | Motor does not turn on when Cup is set on Cup Support | <ul style="list-style-type: none">● Cup is not tall enough to activate motor switch.● The unit features a thermal overload protection circuit. Turn unit OFF, wait 30min. Then turn on again. |
| 3 | Excessive Product splash-out (Some splash-out is common) | <ul style="list-style-type: none">● Ingredients too full● Speed setting too high for ingredients● Agitator fastened tightly to the spindle● Agitator bent or worn. |

Made In China

VEVOR[®]

TOUGH TOOLS, HALF PRICE

Technical Support and E-Warranty Certificate

www.vevor.com/support