

**VEVOR<sup>®</sup>**

**ELECTRIC SAUSAGE STUFFER  
ORIGINAL INSTRUCTION MANUAL**



# VEVOR<sup>®</sup>

**ELECTRIC SAUSAGE STUFFER**  
**XZO-10D/XZA-10D/**  
**XZO-15D/XZA-15D**

XZO-10D/XZA-10D/XZO-15D/XZA-15D

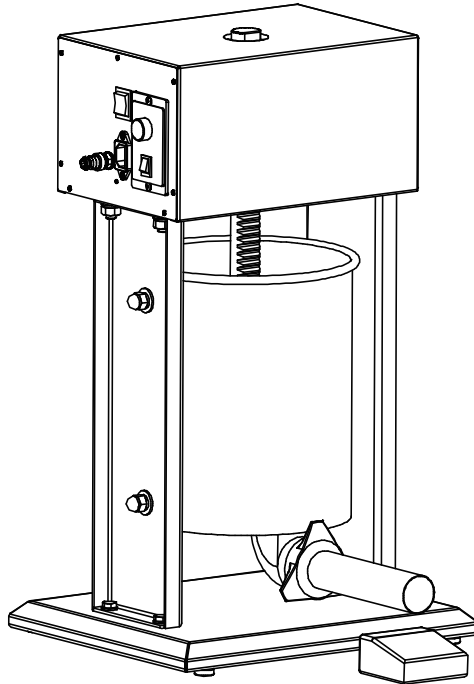

## NEED HELP? CONTACT US!

Have product questions? Need technical support? Please feel free to contact us:

 [CustomerService@vevor.com](mailto:CustomerService@vevor.com)

This is the original instruction, Please read all manual instructions carefully before operating. VEVOR reserves clear interpretation of our user manual. The appearance of the product shall be subject to the product you received. Please forgive us that we won't inform you again if there is any technology or software updates on our product.

## SAFETY INSTRUCTIONS

Dear Users:

Thank you for using this product. In order to make sure that you can operate the machine properly, please read this manual carefully before use. Please be sure to read the SAFETY PRECAUTIONS in this page to ensure your safe use.

1. Please unplug the power of the machine before cleaning, assembling or disassembling.
2. Do not place the product in the reach of children. Children should be supervised to ensure that they do not play with the appliance.
3. This product is not recommended for children or persons with physical, sensory and intellectual disabilities, unless they have gotten the supervision and instruction of how to use the product properly.
4. Do not put hands into the machine during.
5. Do not unplug the machine until it stops running.
6. If the supply cord is damaged, it must be replaced with a special power cord or component provided by the manufacturer.
7. Electric Shock Danger! Non-professional personnel are forbidden to repair the products, otherwise it may result in electrical shock. When a malfunction occurs, it should be repaired by qualified service personnel.
8. WARNING! It is strictly prohibited to put the main body into the water to clean. Only can be scrubbed with wet towel. The machine must be fully cooled before cleaning.
9. Please check that the specified supply voltage in the product is consistent with the supply voltage (AC only).
10. Avoid damage to the power cord. Do not squeeze, bend or friction it, keep it away from heat sources and open fires. The power cord should not touch the blade.
11. Power cord should be laid flat. Do not pull the power cord and make the product fall down, which may cause damage.
12. Do not use the product on wet ground. Do not touch the product or power cord plug with wet hands.
13. Do not disassemble the product at will. Do not allow things to enter or insert into the product, which may cause damage.
14. Only accessories provided by the seller or manufacturer can be used for the product. We will not be responsible for any failure caused by the use of accessories from other manufacturers, which are not covered by warranty.
15. Do not use the product on uneven, damp, non-heat resistant surfaces to avoid damage or failure.
16. Do not place the product directly on the fire or near the source of fire, otherwise the product will be damaged or even result in danger.
17. Do not plug the power cord into the socket when not in use. Please unplug the power cord after use and before cleaning or maintenance.
18. When the plug is plugged into the socket, it must be plugged to the end, otherwise it will cause the components overheating and burning due to poor contact.
19. Do not leave the product to work with no one watching. If the machine is overheating, please stop working immediately and unplug the power.
20. Once part of the product is on fire, do not put out the fire directly with water. Cover the fire with a damp cloth.
21. Please keep the plastic bag properly and do not let children play with it to avoid the risk of suffocation.
22. It is prohibited to put the main body of the machine and the power cord into any liquid.
23. Do not use this product in the following situations:
  - 1) There are problems with the product or power cord.







- 2) The product falls down accidentally, which causes damage or abnormal operation.
- 24.Type X attachment: If the supply cord is damaged, it must be replaced by a special cord or assembly available from the manufacturer or its service agent.
- 25.This appliance can be used by children aged from 8 years and above and persons with reduced physical, sensory or mental capabilities or lack of experience and knowledge if they have been given supervision or instruction concerning use of the appliance in a safe way and understand the hazards involved. Children shall not play with the appliance. Cleaning and user maintenance shall not be made by children without supervision.

## SPECIFICATIONS

Model	XZM-10D	XZA-10D
<b>Product Size</b>	370*310*630mm	370*310*630mm
<b>Capacity</b>	10L	10L
<b>Voltage/Frequency</b>	AC220-240V; 50/60Hz	AC220-240V; 50/60Hz
<b>Power</b>	200W	200W
<b>Speed Threshold</b>	Stepless Speed Regulation	Stepless Speed Regulation
<b>Bucket Fixed Mode</b>	Removable and Tilt	Removable and Tilt
<b>Net Weight</b>	24.4kg	24.4kg
<b>Gross Weight</b>	28.1kg	28.1kg

Model	XZO-15D	XZA-15D
<b>Product Size</b>	370*310*760mm	370*310*760mm
<b>Capacity</b>	15L	15L
<b>Voltage/Frequency</b>	AC220-240V; 50/60Hz	AC220-240V; 50/60Hz
<b>Power</b>	260W	260W
<b>Speed Threshold</b>	Stepless Speed Regulation	Stepless Speed Regulation
<b>Bucket Fixed Mode</b>	Removable and Tilt	Removable and Tilt
<b>Net Weight</b>	26.6kg	26.6kg
<b>Gross Weight</b>	30.7kg	30.7kg

## PARTS LIST

Name	QTY	Diagram
Stuffing tube 16mm	1	
Stuffing tube 22mm	1	
Stuffing tube 32mm	1	
Stuffing tube 38mm	1	
Cleaning brush	1	
Piston rod	1	

## ASSEMBLY AND INSTALLATION

1. Choose a workbench with a suitable height and make sure you have enough room for operation.
2. Please make sure the foot switch is plugged into the machine.
3. Assemble the stuffing tube. Four sizes of stuffing tubes have been provided with the unit (Diameters are 15mm, 21mm, 30mm and 37mm). Choose an appropriate tube and carefully insert it into the fixed collar, slowly tighten it onto the barrel, press down on the packing tube, and make sure it has been stuck and locked.

# EXPLOSIVE VIEW

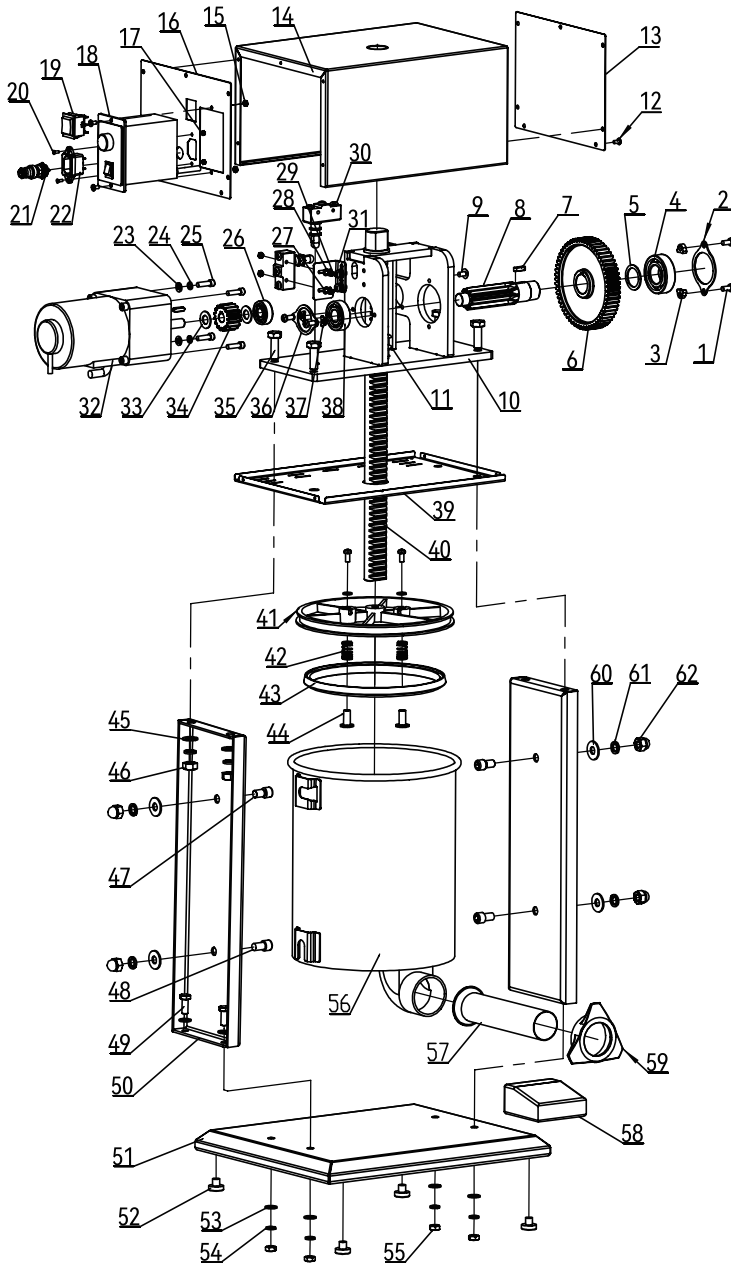

No.	Name	QTY	No.	Name	QTY
1	Screw M6x12t	7	32	Motor	1 Set
2	Bearing Retainer 1	1	33	Closing Ring 2	2
3	Bearing Gasket 1	2	34	Bearing 6205	1
4	Bearing 6205	1	35	Screw M10x30	4
5	Closing Ring 1	1	36	Bearing Retainer 2	1
6	Gear Wheel	1	37	Bearing Gasket 2	2
7	Flat Key 5x18	2	38	Bearing 6203	1
8	Rack Wheel Shaft	1	39	Middle Fixed Plate	1
9	Screw M6x10	4	40	Gear Rack	1
10	Pinion Stand	1	41	Piston	1
11	Flanged Brass Bushing	1	42	Exhaust Pin Spring	1
12	Screw M4x8	23	43	Sealing Washer	1
13	Back Plate	1	44	Exhaust Valves	1
14	Cover	1	45	Flat Washer $\phi$ 10	4
15	Nut M4	5	46	Nut $\phi$ 10	4
16	Lateral Plate1	1	47	Slot Screw M10x16	2
17	Nut M3	2	48	Screw M10x16	2
18	Speed Governor	1	49	Screw M8x20	4
19	Rocker Switch	1	50	Lateral Plate2	2
20	Screw M3x8	2	51	Pedestal	1
21	Aviation Plug	1	52	Sucker	4
22	Socket	1	53	Flat Washer $\phi$ 8	8
23	Flat Washer $\phi$ 6	5	54	Spring Washer $\phi$ 8	4
24	Spring Washer $\phi$ 6	4	55	Nut M8	4
25	Screw M6x20	1	56	Charging Basket	1
26	Bearing 6201	1	57	Packed Pipe	1 Set
27	Flat Washer $\phi$ 4	3	58	Foot Switch	1
28	Spring Washer $\phi$ 4	3	59	Trilobal Cap	1
29	Screw M4x30	2	60	Flat Washer $\phi$ 10	4
30	Limit Switch	2	61	Spring Washer $\phi$ 10	8
31	Fixed Base	1	62	Cap Nut M10	4



## OPERATION

1. Place the pedal in a dry position.
2. Switch ON the power supply, and then set the on-off switch (red) to ON.
3. Turn the REVERSE switch (black) to UP and let the piston move to the top.
4. Tilt the cylinder and place the meat into the cylinder.
5. Place the cylinder back on the frame.
6. Turn the REVERSE switch (black) to DOWN and push the lower side of the footpad. The piston will start to drop.
7. If the piston drops too fast or too slow, use the speed controller (knob) on the side of the electric box to adjust to the appropriate speed.
8. When filling the housing, remove the foot from the pad and the piston will stop.
9. When the piston moves down to the bottom of the cylinder, the device will stop automatically. Then turn the REVERSE switch (black) to UP to lift the piston to the top.
10. Repeat the process from 4 if necessary.

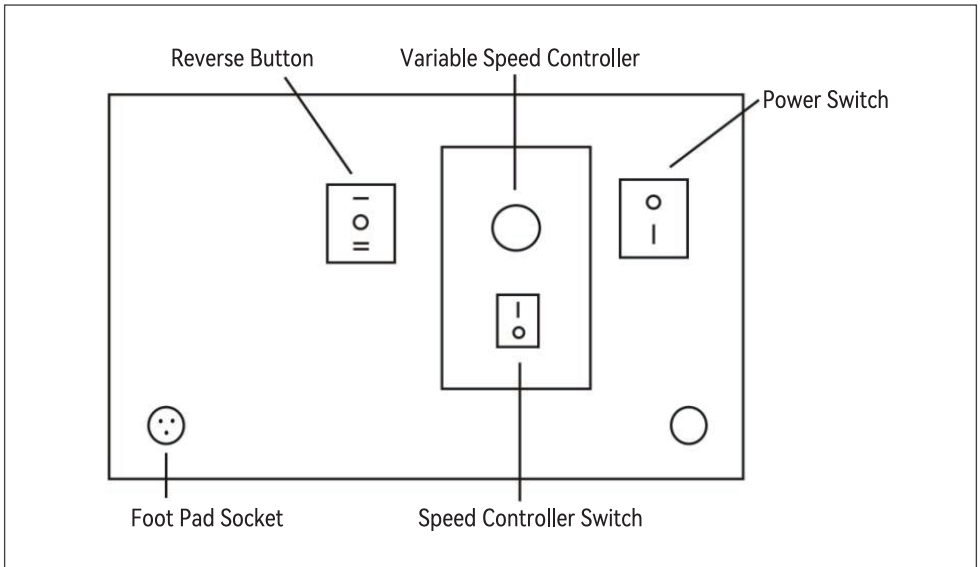

## REPAIR AND MAINTENANCE

1. Please unplug the power supply before cleaning.
2. Remove and clean all parts that come in contact with the sausage.
3. Wipe non-removable parts with a cloth to remove bacteria.
4. Lubricate moving parts and gears to extend product life.
5. Do not use corrosive or abrasive detergents for cleaning.
6. Store the machine in a dry, clean and secure place.

# SCHEMATIC CIRCUIT DIAGRAM

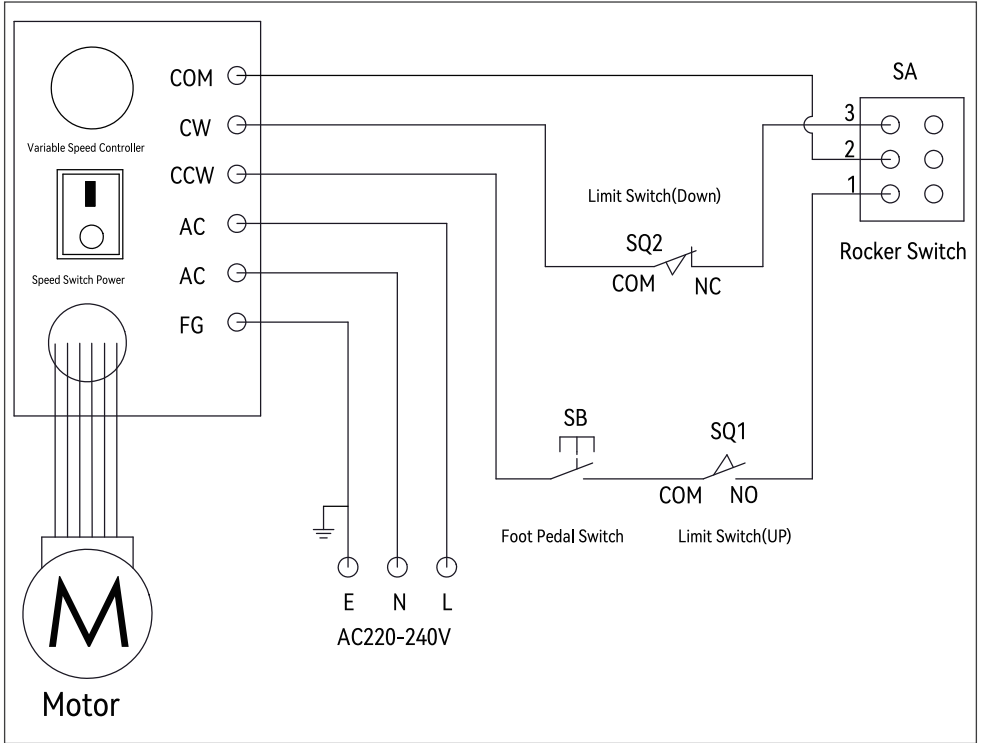

This product is subject to the provision of European Directive 2012/19/EC. The symbol showing a wheellie bin crossed through indicates that the product requires separate refuse collection in the European Union. This applies to the product and all accessories marked with this symbol. Products marked as such may not be discarded with normal domestic waste, but must be taken to a collection point for recycling electrical and electronic devices.



**Manufacture:** Anhui Xuzhong Intelligent Technology Co., Ltd.

**Add:** No. 23, Lantian Road, Economic Development Zone, Wangjiang County, Anqing City, Anhui Province, China

**UK Importer:** FREE MOOD LTD

**Address:** 2 Holywell Lane, London, England, EC2A 3ET

**EC Importer:** WAITCHX

**Address:** 250 bis boulevard Saint-Germain 75007 Paris

<b>UK</b>	<b>REP</b>	EUREP UK LTD UNIT 2264, 100 OCK STREET, ABINGDON OXFORDSHIRE ENGLAND OX14 5DH
-----------	------------	---

<b>EC</b>	<b>REP</b>	EUREP GmbH Unterlettenweg 1a, 85051 Ingolstadt, Germany
-----------	------------	---



**VEVOR<sup>®</sup>**

E-mail: [CustomerService@vevor.com](mailto:CustomerService@vevor.com)