

VEVOR[®]

TOUGH TOOLS, HALF PRICE

Technical Support and E-Warranty Certificate www.vevor.com/support

Airbrush Spray Booth

USER MANUAL

Model:AH-310

We continue to be committed to provide you tools with competitive price.

"Save Half", "Half Price" or any other similar expressions used by us only represents an estimate of savings you might benefit from buying certain tools with us compared to the major top brands and does not necessarily mean to cover all categories of tools offered by us. You are kindly reminded to verify carefully when you are placing an order with us if you are actually saving half in comparison with the top major brands.

VEVOR[®]

Airbrush Spray Booth



NEED HELP? CONTACT US!

Have product questions? Need technical support? Please feel free to contact us:

✉ CustomerService@vevor.com

This is the original instruction, please read all manual instructions carefully before operating. VEVOR reserves a clear interpretation of our user manual. The appearance of the product shall be subject to the product you received. Please forgive us that we won't inform you again if there are any technology or software updates on our product.

WARNING

1. Read carefully and understand all **ASSEMBLY AND OPERATION INSTRUCTIONS** before operating.
2. Failure to follow the safety rules and other basic safety precautions may result in serious personal injury.

GENERAL SAFETY RULES

Please read the entire operating instructions before using the products for the first time; They contain important information about the correct operation.

The guarantee/warranty will be void if damage is incurred resulting from non-compliance with the operating instructions. Liability for any and all consequential damage is excluded!

We do not assume any liability for damage to property or personal injury caused by improper use or the failure to observe the safety instructions! In such cases the guarantee/warranty will be void

The unauthorized conversion, modification or disassembly of the products is inadmissible because of safety and approval reasons (CE).

The product is not a toy and must be kept out of the reach of children. Particular care must therefore be exercised if children are present.

The product must not get damp or wet, it is only intended for use in dry, indoor locations (not bathrooms or similarly damp areas). There is a risk of a fatal electric shock.

Do not expose the product or its accessories to damp or extremely high or low temperatures.

Do not leave packing materials unattended. They may become dangerous

playing material for children.

Dropping, falling, pressure or tensile forces could destroy or at least limit the function of the product.

Never position the device in the vicinity of combustible or easily inflammable materials.

Always make sure that the rotary table on which the object is placed is located in the center of the housing!

The device should continue to run for approximately 2 minutes after each application, which ensures the self-cleaning of the device!

Always turn the device off and pull the mains plug out when the device is not in use!

If the filter is contaminated with substantial amounts of paint, it can no longer work efficiently and must be replaced with a clean filter.

To prevent health damage, never use poisonous, flammable or explosive paints or materials!

Always ensure proper ventilation!

To not impair the extraction performance, you may not extend the extraction pipe!

In commercial institutions, the accident prevention regulations of the employer's liability insurance association for electrical systems and operating facilities are to be observed.

In schools, training centers, hobby and self-help workshops, the use of the product must be supervised by trained personnel in a responsible manner.

If you have reason to assume that safe operation is no longer possible, disconnect the device immediately and secure it against inadvertent operation.

It can be assumed that safe operation is no longer possible if:

- the device shows visible signs of damage,
- the device no longer functions,
- after a longer period of storage under unfavourable conditions,
- following heavy stress during transportation.

SAVE THESE INSTRUCTIONS

MODEL AND PARAMETERS

Model	AH-310
Air Flow	5.2 m ³ /min
Fan	DC12V,0.6A *2pcs
Adapter Input	AC100-240V,50/60Hz, 1.2A
Shrink Dimension	405*220*270mm
Extend Dimension	405*433*330mm
Material	ABS

STRUCTURE DIAGRAM

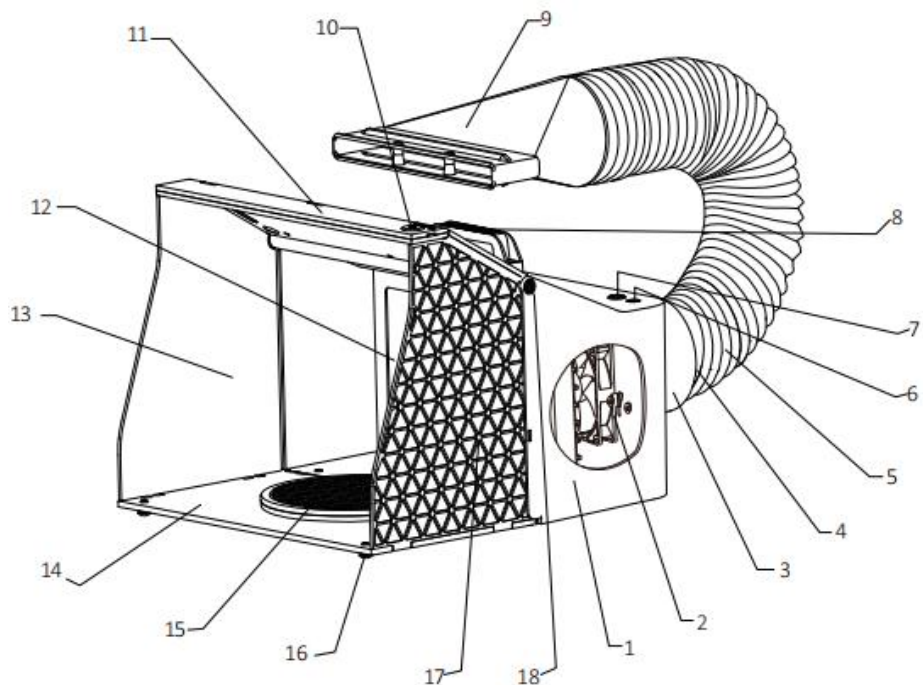

1	Booth body	10	Led light belt switch
2	Fan	11	Light zone plate
3	Connector for duct	12	Filter net for painting
4	Air duct fastening buckle	13	Plate
5	Duct	14	Front cover bed-plate
6	Connector for cord adapter	15	Revolving turntable
7	Switch	16	Rubber feet
8	Handle	17	Plate
9	Duct head	18	Light zone plate port

COMPONENTS

Parts \ Mode	AH-310
Airbrush spray booth	×1
Connector for duct	×1
Air duct fastening buckle	×1
Duct	×1
Duct head	×1
Revolving turntable	×1
Filter net for painting	×1
Filter cotton	×1
Adapter	×1
User manual	×1

OPERATING INSTRUCTIONS

1. Unfold The Lamp Strip Plate.



2. Unfold The Baseplate.



3. Respectively unfold the side plate on both sides, align them with the hole positions of the lamp cover plate, and fasten them.



4. Fix the air-guide connector of duct on spray booth.



5. Connect the duct to connector.



6. Fasten the duct by screwdriver.



7. Extend the hose.



8. Fix the duct head on hose.



9. The assembly is finished.



10. Plug the cord adapter and connect to a power pack.



11. Turn on the switch, the machine will start working.



MAINTENANCE

1. When the product is finished, it is recommended to dry the product and put it away.
2. Do not use damaged device.
3. When cleaning products, be sure to cut off the power supply, then clean the product with a suitable cleaner.

Correct Disposal



■ This product is subject to the provision of European Directive 2012/19/EC. The symbol showing a wheeled bin crossed through indicates that the product requires separate refuse collection in the European Union. This applies to the product and all accessories marked with this symbol. Products marked as such may not be discarded with normal domestic waste, but must be taken to a collection point for recycling electrical and electronic devices

FCC statement

This device complies with Part 15 of the FCC Rules. Operation is subject to the following two conditions: (1) This device may not cause harmful interference, and (2) this device must accept any interference received, including interference that may cause undesired operation.

Address: Baoshanqu Shuangchenglu 803long 11hao 1602A-1609shi
Shanghai



SHUNSHUN GmbH
Römeräcker 9 Z2021,76351
Linkenheim-Hochstetten, Germany



Pooledas Group Ltd
Unit 5 Albert Edward House, The
Pavilions Preston, United Kingdom

Made in China

VEVOR[®]

TOUGH TOOLS, HALF PRICE

TechnicalSupport and E-Warranty Certificate

www.vevor.com/support